



***IWAKI AMERICA
MDM SERIES
MAGNETIC DRIVE PUMP
INSTRUCTION MANUAL***



MDM SERIES INSTRUCTION MANUAL
Table of Contents

1	UNPACKING AND INSPECTION.....	1
2	MODEL IDENTIFICATION GUIDE	2
3	SPECIFICATIONS.....	3
4	HANDLING INSTRUCTIONS	6
5	INSTALLATION, PIPING, AND WIRING.....	9
	■ <i>INSTALLATION POSITION.....</i>	<i>9</i>
	■ <i>PIPING.....</i>	<i>10</i>
	■ <i>SUCTION PIPING</i>	<i>10</i>
	■ <i>DISCHARGE PIPING.....</i>	<i>12</i>
	■ <i>WIRING.....</i>	<i>13</i>
6	OPERATION	14
	■ <i>NOTES ON OPERATION</i>	<i>14</i>
	■ <i>START-UP PREPARATION.....</i>	<i>15</i>
	■ <i>STARTING OPERATION STEPS.....</i>	<i>16</i>
	■ <i>STOPPING OPERATION STEPS</i>	<i>17</i>
7	MAINTENANCE AND INSPECTION.....	17
	■ <i>DAILY INSPECTION</i>	<i>17</i>
	■ <i>PERIODIC INSPECTION</i>	<i>18</i>
	■ <i>REPLACEMENT TOLERANCE CHART</i>	<i>20</i>
8	TROUBLESHOOTING	21
9	PARTS DESCRIPTION AND EXPLODED VIEW	23
10	DISASSEMBLY AND ASSEMBLY OF PUMP.....	24
	■ <i>DISASSEMBLY.....</i>	<i>24</i>
	■ <i>REPLACEMENT OF REAR THRUST COLLAR, RADIAL BEARING, IMPELLER.</i>	<i>25</i>
	■ <i>REASSEMBLY</i>	<i>28</i>
11	SPARE PARTS	31
12	DIMENSIONS.....	32

This product is patent pending.

Thank you for selecting an Iwaki America MDM Series magnetic drive pump. This instruction manual explains the correct handling, operating, maintenance, inspection and troubleshooting procedures for your pump. Please read through it carefully to ensure the optimum performance, safety and long service of your pump.

1 Unpacking and Inspection

Open the package and check that the product conforms to your order. Also, check each of the following points. For any problem or inconsistency, contact your distributor at once.

1. Check that the model number and the HP indicated on the nameplate conform to the specifications of your order.
2. Check that all the accessories you ordered are included.
3. Check that the pump body and parts have not been accidentally damaged or that any bolts or nuts have not loosened in transit.

+ Iwaki Magnet Pump +		
MODEL		
HEAD (m)		
CAPACITY (ℓ/min)		
kw	Hz	rpm
MFG.NO.		
IWAKI AMERICA INC. (Holliston, MA USA)		 +

2P/05251

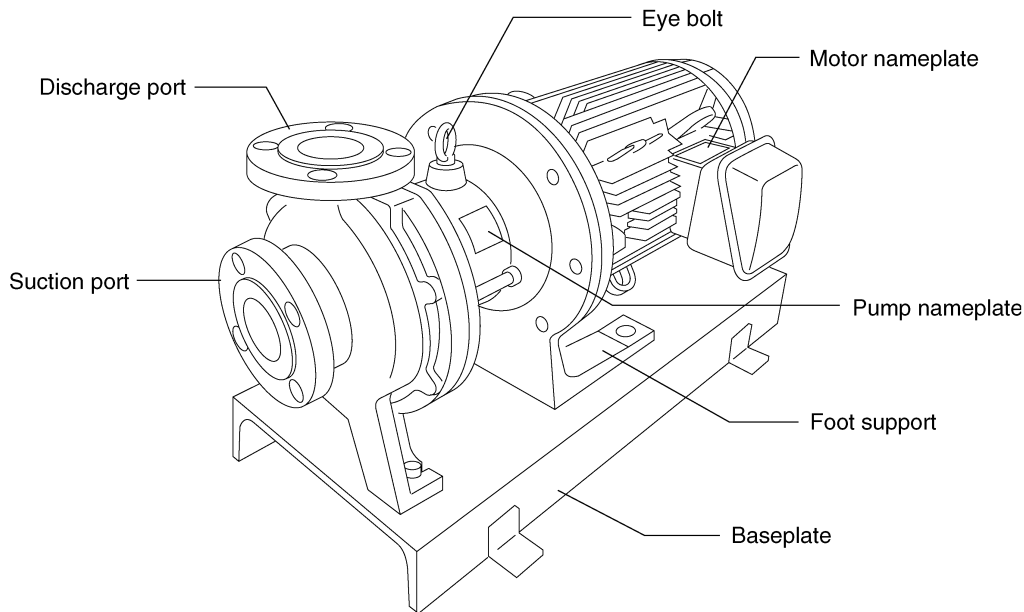

2 Model Identification Guide

MDM	1518	EKK	05	H	S
	1	2	3	4	5

1. Pump Size

Model	Suction	Discharge	Motor HP	Motor Frame
1516*	1 ½	1	2	145TC, FOOTLESS
1516*			3	182TC, FOOTLESS
1518*			5	184TC, FOOTLESS
1518*			7.5	213TC, W/FEET
1518*			10	215TC, W/FEET
1518-2			7.5	213TC, W/FEET
1518-2			10	215TC, W/FEET
1518-2			15	254TC, W/FEET
1518-2			20	256TC, W/FEET
1518-2			25	284TSC, W/FEET
2156			2	1 ½
2156	7.5	213TC, W/FEET		
2156	10	215TC, W/FEET		
2158	7.5	213TC, W/FEET		
2158	10	215TC, W/FEET		
2158	15	254TC, W/FEET		
2158	20	256TC, W/FEET		
2158	25	284TSC, W/FEET		
2526	2 ½	2	5	184TC, FOOTLESS
2526			7.5	213TC, W/FEET
2526			10	215TC, W/FEET
326*	3	2	7.5	213TC, W/FEET
326*			10	215TC, W/FEET
326*			15	254TC, W/FEET
326*			20	256TC, W/FEET
326*			25	284TSC, W/FEET

* Denotes ANSI standard dimensional unit.

2. Liquid End Construction

Bearing option	ECF*	EKK	PKK
Casing Liner/Containment Shell	20% carbon fiber reinforced copolymer ETFE		PFA
Impeller			
Inner Magnet			
Radial bearing	High Density Carbon	SiC	
Shaft	99.8% alumina ceramic		
Front Outboard Thrust Collar	99.8% alumina ceramic		
Front Inboard Thrust Collar	PTFE (w/filler)		
Rear Inboard Thrust Collar	99.8% alumina ceramic		
Rear Outboard Thrust Collar	PTFE (w/filler)		
Casing Gasket	PTFE		

* Dry run capable configuration

3. Motor Size

02, 03, 05, 07, 10, 15, 20, 25	2 HP through 25 HP
--------------------------------	--------------------

4. H = High Temperature Version (only available on 1518-2 and 2158 models)

5. S = Slurry Bearing System

3 Specifications

Model	Connections Suct x Disch 150# (inch)	Nominal Impeller Dia. (inch)	BEP Capacity @60Hz (GPM)	BEP Head (ft)	Min Flow rate (GPM)	Nominal Motor (RPM)	Motor (HP)
1516	1½ x 1	5.52	50	108	5	3500	2, 3
1518	1½ x 1	6.7	70	167			5, 7.5, 10
1518-2	1½ x 1	8.86	120	310	13		7.5, 10, 15, 20, 25
2156	2 x 1½	5.71	150	116			5, 7.5, 10
2158	2 x 1½	8.86	130	190			7.5, 10, 15, 20, 25
2526	2½ x 2	6.3	225	118			5, 7.5, 10
326	3 X 2	6.7	275	150			7.5, 10, 15, 20, 25

Notes:

- Rated performance (head/capacity) represents the maximum discharge head/capacity measured with water at 68°F (20°C).
- Liquid temperature range:

ETFE type:	32 – 221 °F (0 - 105° C)
PFA type:	32 - 250 °F (0 - 120 °C) (1518-2 and 2158 models)
	32 – 302 °F (0 – 150 °C) *

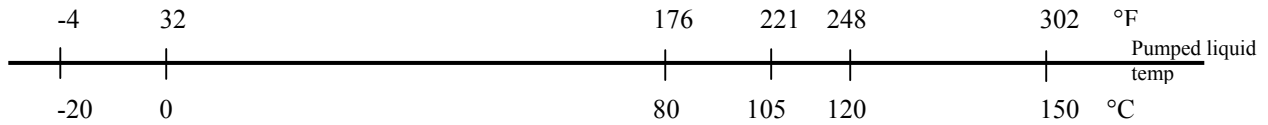

* For liquid temperatures 248 – 302°F (120 – 150°C) please consult Iwaki America.

- PFA / ETFE material MDM1518-2 and 2158
- ETFE material All models (except MDM1518-2 and 2158)
- PFA material MDM1518-2 and 2158 high temperature
- PFA material MDM1516, 1518, 2156, 2526, 326

Ambient temperature range : 32 – 104 °F (0 – 40 °C)
 Ambient humidity range: 35 – 85% RH

3. Max Allowable Working Pressure (MAWP) for MDM1516, 1518, 2156, 2526 and 326 is 150 psi (1.03 MPa). For MDM 1518-2 and 2158 MAWP is 250 psi (1.72 MPa)
4. Slurry: In general, slurries should not be handled. However, a pump with a silicon carbide bearing system, KK, can handle slurries if the hardness is 80Hs or below, with a maximum grain size of 2 MIL (50 microns) and maximum density 10% wt. Consult Iwaki America or your distributor for details regarding applications using slurries greater than 5%.

■ **Materials of Main Components**

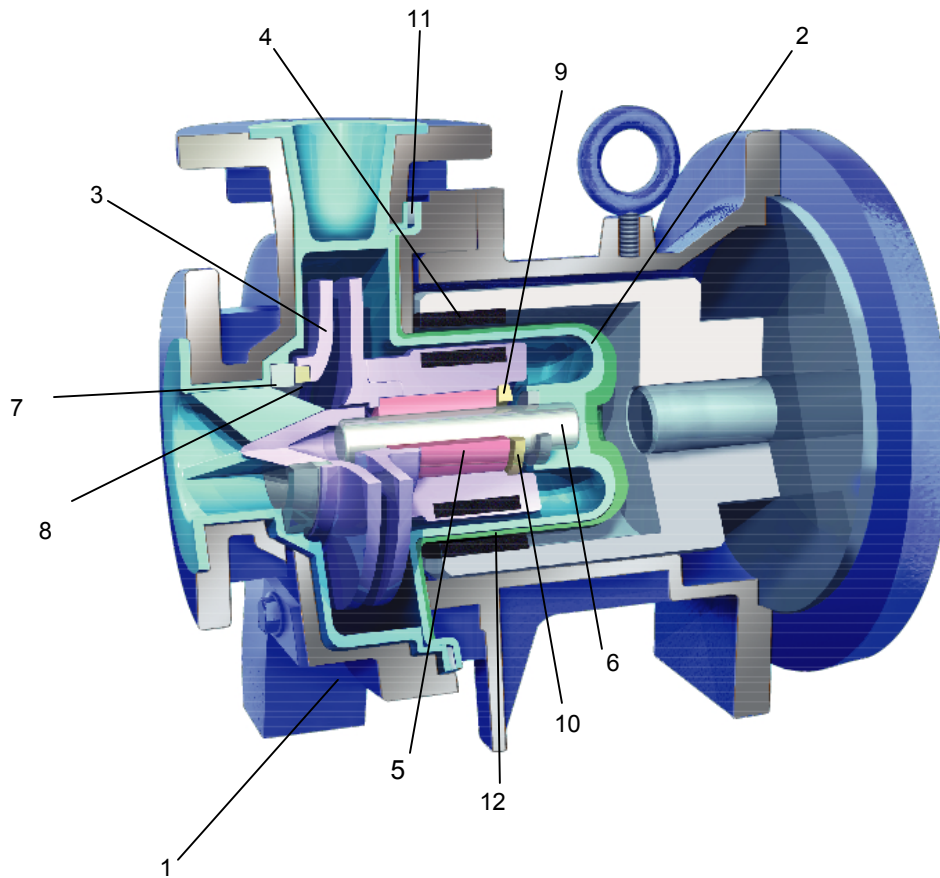

	Material code	ECF	EKK	PKK
1	Front casing liner	20% CFRETFE (carbon fiber reinforced ETFE)		100% PFA
2	Rear casing			
3	Impeller			
4	Inner magnet			
5	Bearing	High Density Carbon	SiC	
6	Shaft	High purity Alumina Ceramic		
7	Outboard forward thrust collar	PTFE		
8	Inboard front thrust collar	High purity alumina ceramic		
9	Inboard rear thrust collar	PTFE (w / filler)		PTFE
10	Outboard rear thrust collar	PTFE		
11	Gasket	PTFE		
12	Support*	Kevlar®		

* High temperature versions only (1518-2 and 2158)

4 Handling Instructions

1. Do not operate the pump dry

The sliding parts used in the MDM series pump are lubricated and cooled by the fluid being pumped. Never intentionally operate the pump dry or with the valves on the suction side closed. Otherwise, the inside of the pump will be damaged.

Some MDM models are designed to tolerate brief or intermittent dry run operation, they are identified by the "CF" bearing system identifier in the model number. These models can tolerate dry run conditions for up to one hour. Longer dry run periods, or frequent dry running, may result in premature wear of the bushing and shaft. This can rapidly affect the standard clearances of the rotating elements inside the pump. If the pump is unavoidably or accidentally operated dry, with no obvious damage, allow the pump to cool down for a minimum of one hour before attempting to restart. Do not allow fluid to enter the pump cavity until the pump has cooled down. Sudden or rapid cooling of the pump may cause damage to the ceramic bushing system. A dry run monitoring device (current or power sensor) is recommended for the prevention of damage when dry run operation is likely.

2. Starting and Stopping

Pay close attention to the following points to avoid water hammer upon starting and stopping of pump operation. Extra attention is required when the discharge piping is very long.

Starting

Prior to starting the pump, make sure that the power is turned off. Then carry out priming to fill the pump cavity with liquid.



Caution! Manually rotate the pump drive shaft before start up to ensure ventilation of trapped air. Failure to do so may result in damage to the pump bearing system.

Next, close the valves on the discharge side. Now you can turn the power on and start up the pump. When the pump has reached full speed and line pressure is stable, the discharge valve can be opened to the desired pressure setting.



Caution! If the pump is operated with air remaining within the pump cavity, pitting, cracking, or breakage of the bushing and/or thrust collar may occur, causing damage to the pump.

Stopping

When stopping the pump, first close the discharge valve gradually. When it is completely closed, turn off the power switch so that the pump stops. Never stop the pump suddenly by quickly closing a valve (i.e., solenoid or hydraulic valves).



Caution! Quick valve closure may cause water hammer which can cause severe damage to the pump.

3. Maximum system pressure rating

Max Allowable Working Pressure (MAWP) for MDM1516, 1518, 2156, 2526 and 326 is 150 psi (1.03 MPa). For MDM 1518-2 and 2158 MAWP is 250 psi (1.72 MPa)

4. Handling of slurry liquid

In general, slurries should not be handled. However, a pump with a SiC bearing system, can handle slurries if the hardness is 80 Hs or below, with a standard maximum grain size of 2 MIL (50 microns) and the maximum density 5% wt. Slurries of higher concentrations may be possible with the use of slurry bearing design. Contact Iwaki America or your distributor for application review.

5. Influence of specific gravity on pump performance

The performance of the MDM pump does not change when pumping fluids of high specific gravity. However, the effect of specific gravity on shaft power and magnet coupling torque requirements must be considered in the selection of the appropriate model for your application.

6. Influence of liquid viscosity on pump performance

When pumping a high viscosity liquid, the discharge head and capacity of the pump may be lower than in the case of pure water. The required driving power may also vary and should be verified.

7. Intermittent operation

Frequent start/stop switching shortens the service life of the pump. Limit the frequency of switching on or off to six times or less per hour.

8. Effects of temperature

The pump itself may not suffer a change in performance due to temperature fluctuation. However, the liquid may change in terms of viscosity, vapor pressure, and corrosive properties. Pay special attention to changes in liquid characteristics as a result of temperature fluctuation.

Refer to corrosion resistance tables for the recommended temperature range for various types of liquids. In case of any questions, contact Iwaki America or your distributor to determine if operation is feasible.

9. Separation of magnet coupling (decoupling)

If the magnet coupling should disconnect, stop the pump immediately. If operation is continued, the torque rating of the coupling will be permanently reduced.

10. Operation within range of bell-shaped head/capacity curve

In the case of a pump which generates a bell-shaped capacity curve in a low-flow range, do not operate the pump in the section where the line ascends. (Refer to the standard performance curve to verify the head/capacity). If the rightward ascending section of the head/capacity curve is part of the pump operation specifications, design the piping by observing the following points:

1. The discharge piping should have no water tank or air trap,
2. The discharge quantity must be adjusted by a valve which is installed close to the discharge port of the pump.

5 Installation, Piping, and Wiring

■ *Installation Position*

1. Install the pump as close to the suction tank as possible (flooded suction). If the suction port of the pump is positioned higher than the suction tank (suction lift), be sure to arrange a foot valve in the suction pipe. The lifting capability depends upon the liquid properties, temperature, and length of suction piping. For details, consult Iwaki America or your distributor.
2. The pump can be installed indoors or outdoors. However, there should be sufficient space around the pump to enable efficient and easy maintenance.

Installation

1. The pump anchoring area must be greater than the area of the pump baseplate. If the anchoring area is not large enough, the baseplate may be damaged due to the concentration of loads placed on it.
2. Set the pump baseplate on a concrete foundation and fasten the anchor bolts tightly to prevent the pump from vibrating during operation. A sturdy metal (or reinforced) skid or platform is also an acceptable mounting surface.
3. Insert a spacer between the concrete surface and the bottom of the base to level the pump horizontally. Next put a level on the discharge flange surface to adjust the pump horizontally in the direction of the pump shaft. Also adjust the direction vertical to the pump shaft at the same time by placing a level on the suction flange surface. Pour cement mortar into the anchor bolt holes after leveling has been completed. When the cement mortar is hardened, fasten the anchor bolt nuts firmly. (See Figure 3).
4. In case there is influence of motor vibration during operation (e.g. sympathetic vibration with piping), an expansion joint should be provided between the pump and the piping before installation. Otherwise, pipes and gauges may be damaged.

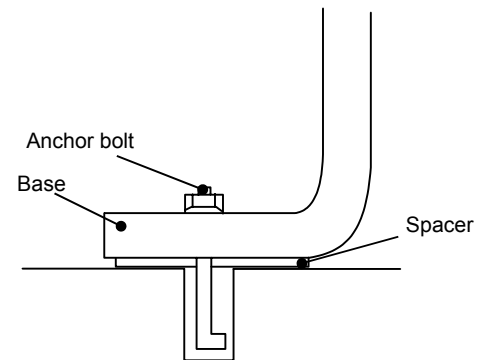

■ **Piping**

1. Discharge pipe (use a support
To keep the pump free from the
load of the pipe)
 2. Gate valve
 3. Check valve
 4. Pressure gauge
 5. Motor
 6. Pump
 7. Priming pump
 8. Gate valve
 9. Pump base
 10. Compound gauge
 11. Suction pipe (shortest horizontal
section with an ascending gradient
toward the pump)
 12. Pipe support
 13. Pump drain
 14. Suction pipe
 15. Suction pipe stabilizer brace
(used if suction pipe is particularly
long)
 16. Foot valve
 17. 1.5D* or more
 18. 24 inches or more
 19. 1-1.5D* or more (if sediment
accumulates easily)
 20. Suction tank
 21. Screen
 22. Short pipe
- * Pipe diameter

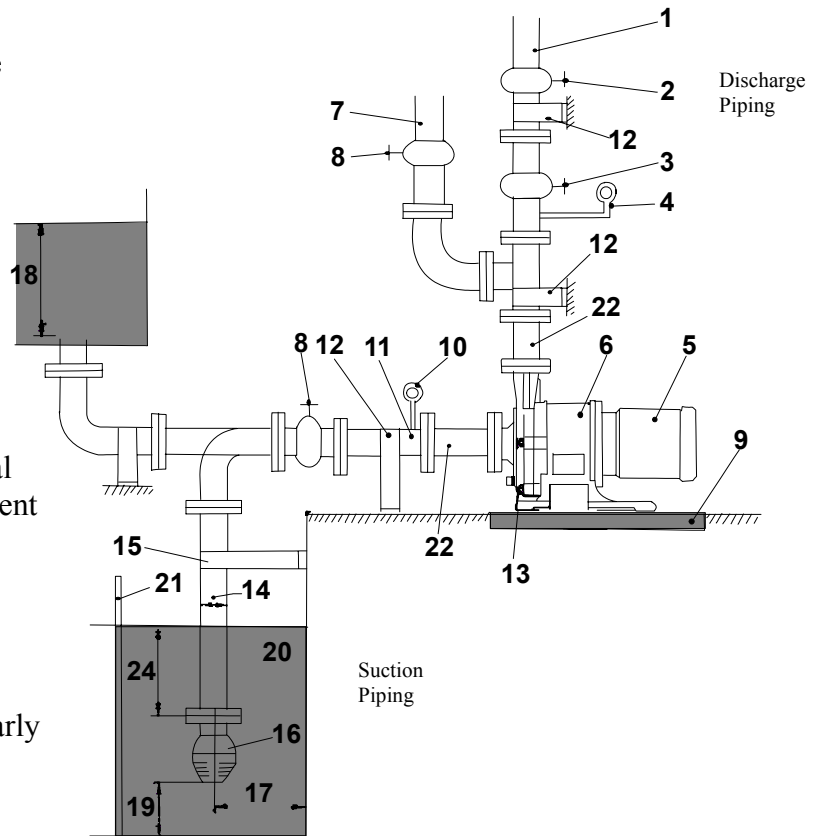

■ **Suction Piping**

1. The suction pipe should employ the flooded suction method if possible. The shortest pipe possible, with the minimum number of bends, should be designed. Arrange a proper support on the suction pipe so that the load and the thermal stress of the pipe itself are not applied to the pump.
2. Attach the coupling on the suction pipe carefully, so that no air enters the line. The presence of air in the suction pipe may prevent priming of the pump.
3. Avoid installations with poor suction conditions (e.g. vacuum in suction tank, large suction head or long suction piping). NPSHa should always be at least 2 feet greater than NPSHr. For NPSHr values, refer to the standard performance curve for your pump model or contact Iwaki America or your distributor.

4. When using a bend on the suction side, install a straight pipe which is more than 20 inches long or 10 times as long as the suction port diameter before the suction port of the pump. Use the largest possible radius of curvature for the bend.
5. Do not allow any projection where air may be trapped along the suction pipe. The suction pipe should have an ascending gradient toward the pump.
6. If the diameters of the pump suction port and the suction pipe are different, use an eccentric reducer pipe. Connect the eccentric reducer pipe such that the upper part of it is level. **Never use a suction pipe with a diameter smaller than that of the pump's suction port.**
7. When using the flooded suction method, the suction pipe should be given a slight ascending gradient toward the pump so that no air pocket is created on the suction side.
8. The end of the suction pipe should be located 24 inches or more below the surface of the liquid.
9. A screen should be provided at the inlet of the suction tank to prevent the entrance of foreign matter into the suction pipe. Foreign matter may cause malfunctioning of and/or damage to the pump. The end of the suction pipe should be at least $1 - 1.5D$ from the bottom of the suction tank. (D =Diameter of suction pipe).
10. When employing the suction lift method, install a foot valve on the suction pipe.
11. When using the flooded suction method, it is recommended that a gate valve be installed on the suction pipe for easier overhaul inspection of the pump. Since this valve is used only in the overhaul inspection of the pump, keep it fully opened during normal pump operation.
12. Pay close attention to the lowest level of the liquid in the suction tank to avoid vortexing, air entrapment and associated suction piping concerns.

The inflow pipe into the suction tank should be distanced from the suction pipe and positioned below the liquid surface as a means of preventing air entrapment to the suction pipe. If air bubbles are generated in the suction tank, install a baffle.

13. It is recommended that a vacuum/pressure gauge be installed on the suction piping approximately 6 pipe diameters from the pump suction port.

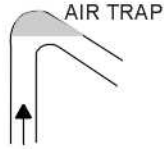
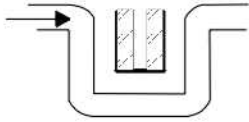
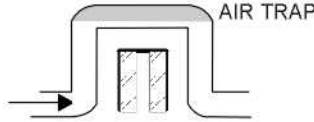
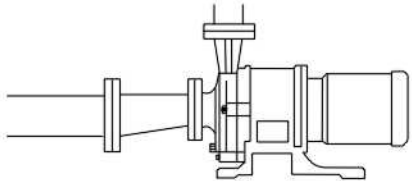
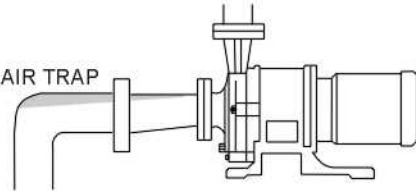
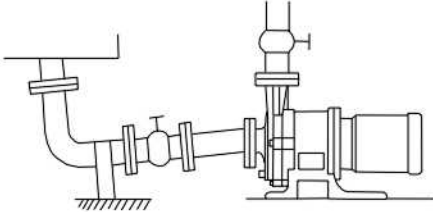
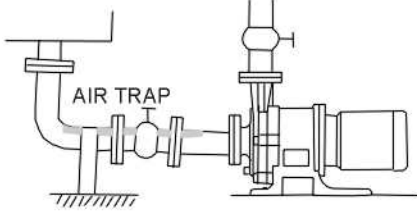
GOOD CONDITIONS	UNACCEPTABLE CONDITIONS
	
	
	
	

■ **Discharge Piping**

1. Use proper pipe supports so that the weight of the piping does not load the pump nozzle.
2. If a method other than flooded suction is used, install a special pipe for priming.
3. If the piping is very long, its diameter should be determined by calculating the piping resistance. Otherwise, the specified performance may not be obtained due to increased piping resistance.
4. A check valve should be installed if any of the following conditions exists in the piping:
 - The discharge piping is very long.
 - The discharge head is 50 feet or more.
 - The end of the discharge pipe is located 30 feet higher than the surface of the suction tank.
 - Several pumps are connected in parallel with the same piping.

5. The installation of a gate valve on the discharge pipe is recommended for the adjustment of discharge quantity and for the prevention of motor overload. When installing both a check valve and a gate valve, the check valve should be positioned between the pump and the gate valve.
6. A pressure gauge must be installed on the discharge piping, prior to the gate valve.
7. An air bleeding valve should be installed if the discharge pipe is very long in the horizontal direction.
8. A drain valve should be installed for the drainage of liquid if there is a chance that the liquid in the discharge pipe will freeze.

■ **Wiring**

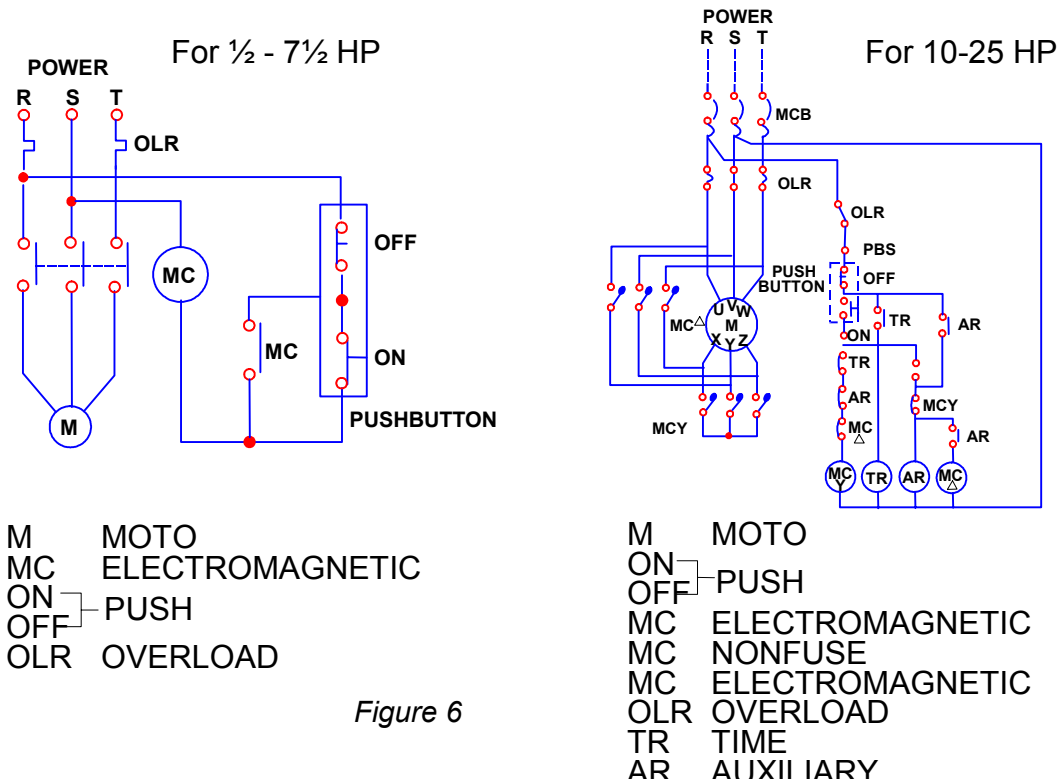

Use appropriate wiring materials, follow the instruction manual for the motor and abide by the local and national electrical codes. In addition, follow the instructions given below:

1. Use a motor contactor that conforms to the specifications (voltage, current, etc.) of the pump motor.
2. If the pump is installed outdoors, use waterproof wiring to protect the switches from rainwater and moisture.

3. The motor contactor and push button should be installed a reasonable distance from the pump.
4. For pumps using a motor of 10 HP or larger, use of a soft start motor voltage/amperage device is recommended.

Refer to the wiring examples shown above. (These examples do not include the installation of a dry run prevention device. Follow the instruction manual of the dry run prevention device when installing it.)

6 Operation

■ Notes on Operation

1. Never operate the pump with the suction valve (gate valve) closed. Otherwise, the internal bushing of the pump may be damaged. Refer to Handling Instructions regarding dry run designs.
2. In the event of cavitation, stop the pump immediately.
3. If the magnet coupling disconnects, stop the pump immediately. The torque rating of the magnet coupling will be reduced if operation is continued with the inner and outer magnets de-coupled.
4. Liquid temperature fluctuation should not exceed 144^o F (62°C) when starting, stopping, and operating the pump.
5. Be sure to partially close the discharge valve prior to start-up in order to prevent water hammer.
6. The pump should never be operated with the discharge valve fully closed for longer than one minute. A resulting rise in temperature of liquid within the pump may cause damage.
7. In the event of a service power failure, turn off the power switch immediately and partially close the discharge valve.

■ **Start-Up Preparation**

When operating the pump for the first time after installation, and when restarting operation after a long interval, prepare for operation as described below.

1. Thoroughly clean the inside of the piping and pump.
2. Tighten the union fittings or flange connecting bolts and baseplate installation bolts. Check the torque of the bolts which couple the front casing and the bracket together.
3. Close the cocks of any pressure or vacuum gauges to prevent damage from sudden pressure changes. Open only when taking measurements.
4. Fully open the suction gate valve and partly open the discharge valve. Discharge valve may be adjusted after completion of priming and start-up process.
5. Use a screwdriver to rotate the motor fan and check that the fan rotates smoothly. This also purges any residual air from in and around the impeller, ensuring ventilation of entrapped air in pump casing. Failure to do so may result in damage to pump bearing system.
6. If using flooded suction, measure the pressure in the suction pipe to verify that the pump is filled with liquid. In the case of the suction lift method, simultaneously carry out priming and rotate the motor fan using a screwdriver to rotate the pump and remove any air trapped in the impeller section.
7. Run the motor momentarily to check the direction of motor rotation. The motor should run in the direction indicated by the arrow cast on the pump casing. If the direction is reversed, exchange two wires of the three-phase power wires.

Note: All Iwaki America MDM series pumps rotate counter-clockwise when looking at the suction port of the pump. From the motor fan side, this would be viewed as clockwise.

■ **Starting Operation Steps**

Pump operation is detailed below.

Operation Step	Notes
1. Verify valve position	Suction valve should be fully open, discharge valve closed.
2. Check that the pump is filled with liquid.	If the pump is not full of liquid, fill it according to steps 5 & 6 of “Startup Preparation.”
3. Turn motor switch ON momentarily to check for correct direction of pump rotation	Note the arrow direction on the casing to confirm the direction of rotation (clockwise when viewed from the motor fan side).
<p>Flow rate adjustment:</p> <p>Once total discharge pressure is increased to close to shut off pressure, open discharge valve gradually to set discharge pressure to desired specification.</p>	Open valve slowly, paying attention to the motor ammeter to prevent it from being overloaded through excessive opening of the valve.
<p>Pump should be operated at a minimum flow rate of:</p> <p>Models MDM1516, 1518</p> <p>Models MDM1518-2, 2156, 2158, 2526, 326</p>	<p>5 GPM (20 LPM)</p> <p>13 GPM (50 LPM)</p>
<p>In case of automatic control, partially close discharge valve when starting pump and gradually open the discharge valve thereafter.</p> <p>Do not operate the pump with the discharge valve closed for more than one minute.</p>	
<p>Points to be observed during operation:</p> <p>If the pump enters continuous operation condition, check flow meter and confirm that pump operation meets specifications.</p> <p>If flow meter is unavailable, check values of discharge pressure, suction pressure and current in relation to piping resistance.</p>	

■ **Stopping Operation Steps**

Operation Step	Notes
1. Close discharge valve gradually.	 Caution! Do not cause sudden closure by using solenoid valve, etc. Pump may be damaged by water hammer.
2. Stop motor.	Observe that the motor stops rotating slowly and smoothly. If not, check inside of pump.
<p>Points to be observed when stopping:</p> <p>If pump operation is stopped in cold weather, liquid inside the pump cavity may freeze and damage the pump. Be sure to drain liquid completely. In case of short term shut down, which does not allow removal of liquid, use band heater to prevent liquid from freezing.</p> <p>In case of service power failure, turn power switch OFF and close discharge valve.</p>	

7 Maintenance and Inspection

■ **Daily Inspection**

1. Check that the pump operates smoothly, without generating abnormal sounds or vibration.
2. Check the level of the liquid in the suction tank, and the suction pressure.
3. Compare the discharge pressure and current measured during operation with the specifications indicated on the motor and pump nameplates to verify normal pump load.

Note that the indicated value of the pressure gauge varies in proportion to the specific gravity of the liquid.

Note: The valve of the pressure gauge or vacuum gauge should be opened only when measurements are recorded. It must be closed after completion of each measurement. If the valve remains open during operation, the gauge mechanism may be affected by abnormal pressure caused by water hammer.

4. If a spare pump is included in the installation, keep it ready for use by operating it from time to time.

■ **Periodic Inspection**

1. To ensure efficient, smooth operation of the pump, carry out periodic inspection by following the procedure described below. Inspection records should be maintained.
2. When carrying out an overhaul inspection, handle the internal bushings and plastic components most carefully. Since the outer drive magnet and inner magnet capsule are very powerful, handle these components with caution. Take care not to trap hands and fingers between the magnets and metal objects. Also avoid positioning the magnets near any electronic device that could be affected by a strong magnetic field (i.e.. ATM cards or computer disks) .

Inspection Interval	Part	Inspection Points	Operator Action
Every 6 months	Outer magnet assembly	<ul style="list-style-type: none"> ▪ Check for scoring ▪ Is magnet mounted normally? Is hexagonal socket set screw loose? ▪ Is inner perimeter of magnet & motor shaft concentric? 	<ul style="list-style-type: none"> ▪ Contact distributor if any abnormality is found. ▪ Reinstall magnet on motor shaft and fasten hexagonal socket set screws. ▪ Re-tighten or replace hexagonal socket set screws.
Every 3 months	Containment shell	<ul style="list-style-type: none"> ▪ Check for scoring on inner diameter. ▪ Are there any cracks in liquid-containing section? ▪ Wear of thrust collar? ▪ Stain in containment shell? 	<ul style="list-style-type: none"> ▪ Contact distributor if abnormality is observed. ▪ Replace if abnormality is observed. ▪ Replace if abnormality is observed ▪ Clean.
	Containment shell cover	<ul style="list-style-type: none"> ▪ Is there scoring? ▪ Improper installation in frame? 	<ul style="list-style-type: none"> ▪ Contact your distributor if abnormality is observed. ▪ Adjust.

Inspection Interval	Part	Inspection Points	Operator Action
Every 3 months	Inner magnet assy	<ul style="list-style-type: none"> ▪ Is there scoring on rear face or cylindrical body? ▪ Are there any cracks in the plastic of the rear section or cylindrical body? ▪ Bushing wear. 	<ul style="list-style-type: none"> ▪ Contact distributor if any abnormality is observed. ▪ Contact distributor if any abnormality is observed ▪ Replace if abnormality is observed. (See Tolerance chart)
	Impeller	<ul style="list-style-type: none"> ▪ Are there any cracks? ▪ Are there any cavitation marks? ▪ Stain or clogging inside impeller? ▪ Dimensional change of impeller? 	<ul style="list-style-type: none"> ▪ Replace if abnormality is observed. ▪ Eliminate cause. ▪ Clean. ▪ Replace if abnormality is observed.
Every 3 months	Front casing liner	<ul style="list-style-type: none"> ▪ Stain in liquid-contacting section? ▪ Are there any cracks? ▪ Wear or crack on inboard thrust collar? ▪ Expansion or wear of o-ring? ▪ Scoring on inner surface? 	<ul style="list-style-type: none"> ▪ Clean ▪ Replace if abnormality is observed. ▪ Contact distributor if abnormality is observed. ▪ Replace if part is damaged. ▪ Contact distributor if abnormality is observed.
	Shaft	<ul style="list-style-type: none"> ▪ Are there any cracks? ▪ Wear on surface? 	<ul style="list-style-type: none"> ▪ Replace if abnormality is observed. ▪ Replace if wear limit is exceeded.

■ Replacement Tolerance Chart

Dimensions in inches (mm)

Model	MDM1516		MDM1518, 1518-2, 2156, 2526		MDM2158, 326	
	N	W	N	W	N	W
(N)= New (W) = Worn						
(A) Bushing ID *	0.79 (20)	0.83 (21)	1.02 (26)	1.06 (27)	1.18 (30)	1.22 (31)
(B) Shaft OD*	0.79 (20)	0.75 (19)	1.02 (26)	0.98 (25)	1.18 (30)	1.14 (29)
(C) Thickness of outer thrust collar **	0.32 (8)	0.24 (6)	0.32 (8)	0.24 (6)	0.35 (9)	0.28 (7)

- * If the difference between Bushing ID and shaft OD exceeds 0.039 in (1mm), either the bushing or the shaft, whichever has greater wear, should be replaced regardless of the values in the above table. In case of a ceramic bushing type pump, the shaft and the bushing should be replaced simultaneously.

Initial wear may appear in the sliding part in the first stages of operation. This should not be mistaken for an abnormal condition.

- ** The step between the surfaces of the outboard thrust collar and the impeller upon shipment is .079 in. (2mm). Replacing the outboard thrust collar is recommended when this step is reduced to zero (0) in.

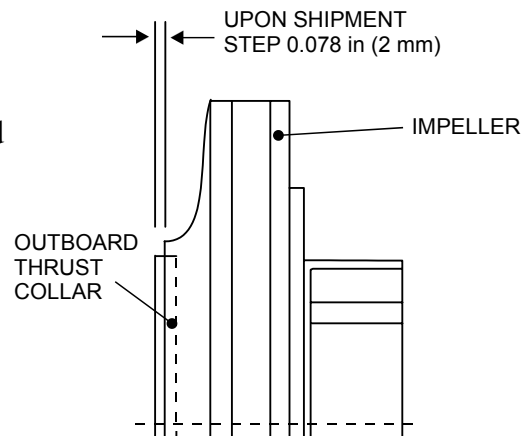

8 Troubleshooting

Problem	Symptom on Pump		Cause	Inspection & Correction	
	Discharge valve closed	Discharge valve open			
Liquid is not pumped		Pressure gauge & vacuum gauge indicate zero	<ul style="list-style-type: none"> ▪ Insufficient priming ▪ Dry run operation 	<ul style="list-style-type: none"> <input type="checkbox"/> Stop pump, feed priming liquid & restart <input type="checkbox"/> Replace strainer 	
	Liquid level drops immediately when priming		<ul style="list-style-type: none"> ▪ Foot valve clogged with foreign matter 	<ul style="list-style-type: none"> <input type="checkbox"/> Check whether valve seat is clogged 	
				<ul style="list-style-type: none"> ▪ Air enters thru suction pipe or gasket section 	<ul style="list-style-type: none"> <input type="checkbox"/> Check that connection flange in suction piping is sealed airtight <input type="checkbox"/> Check whether suction liquid level is abnormally low
	Liquid level drops if discharge valve is opened after starting operation	Pressure & vacuum gauge needles swing but return to zero immediately		<ul style="list-style-type: none"> ▪ Magnet coupling is disconnected (de-coupled) 	<ul style="list-style-type: none"> <input type="checkbox"/> Stop pump & use a screwdriver to check for easy & smooth rotation of motor fan. <input type="checkbox"/> Measure current level to check for low reading <input type="checkbox"/> Check for foreign matter inside pump cavity <input type="checkbox"/> Check whether voltage level is normal <input type="checkbox"/> Replace outer magnet and/or inner magnet assembly <input type="checkbox"/> Confirm fluid specific gravity & magnet rating, determine if S.G. exceeds magnet rating
				<ul style="list-style-type: none"> ▪ RPM of pump is insufficient ▪ Pump rotation is reversed 	<ul style="list-style-type: none"> <input type="checkbox"/> Check wiring & motor and fix as necessary <input type="checkbox"/> Correct motor wiring
Discharge quantity is small.	Needles of pressure & vacuum gauges indicate normal values.	Vacuum gauge indicates high value.	<ul style="list-style-type: none"> ▪ Strainer is clogged with foreign matter & liquid passage is blocked. 	<ul style="list-style-type: none"> <input type="checkbox"/> Remove foreign matter in strainer. 	
		Vacuum gauge indicates abnormally high value.	<ul style="list-style-type: none"> ▪ Air is trapped in suction pipe. ▪ Inlet section of impeller unit is clogged with foreign matter. 	<ul style="list-style-type: none"> <input type="checkbox"/> Inspect installation of suction pipe & modify as necessary. <input type="checkbox"/> Partially disassemble unit & remove foreign matter. 	
		Pressure & vacuum gauges fluctuate.	<ul style="list-style-type: none"> ▪ Air enters via suction pipe or gasket section. ▪ Discharge side of pump is clogged with foreign matter. 	<ul style="list-style-type: none"> <input type="checkbox"/> Check flange gaskets of suction pipe & tighten. <input type="checkbox"/> Remove foreign matter or scale inside of piping. 	
		Vacuum gauge reads high while pressure gauge indicates normal value.	<ul style="list-style-type: none"> ▪ Air pocket or resistance in suction pipe. 	<ul style="list-style-type: none"> <input type="checkbox"/> Inspect suction piping installation & make corrective adjustments. 	
		Pressure gauge reads high while vacuum gauge indicates normal value.	<ul style="list-style-type: none"> ▪ Discharge piping section causing high resistance or actual head & loss of head is too high. 	<ul style="list-style-type: none"> <input type="checkbox"/> Check actual head & piping loss of discharge pipe & take necessary measures. 	

Problem	Symptom on Pump		Cause	Inspection & Correction
	Discharge valve closed	Discharge valve open		
Discharge capacity is small	Pressure gauge reads low & vacuum gauge reads very low	Pressure & vacuum gauges indicate low values	<ul style="list-style-type: none"> ▪ Rotating direction of pump/motor is reversed. 	<ul style="list-style-type: none"> <input type="checkbox"/> Correct motor wiring to reverse rotation (clockwise when viewed from motor side)
Motor overheats			<ul style="list-style-type: none"> ▪ Insufficient voltage ▪ Overload ▪ Ambient temperature is high. 	<ul style="list-style-type: none"> <input type="checkbox"/> Check whether voltage & frequency levels are adequate. <input type="checkbox"/> Check whether specific gravity & viscosity of liquid are above spec. Stop pump & use screwdriver to check whether motor fan rotates easily & smoothly. <input type="checkbox"/> Improve air ventiation.
Discharge capacity is suddenly lowered.		Vacuum gauge reads high	<ul style="list-style-type: none"> ▪ Strainer is clogged with foreign matter 	<ul style="list-style-type: none"> <input type="checkbox"/> Remove foreign matter.
Pump vibrates			<ul style="list-style-type: none"> ▪ Foundation is inadequate. ▪ Anchor bolt is loose. ▪ Suction pipe is closed. Cavitation is caused. ▪ Wear or melting of pump bearing. ▪ Damaged inner magnet assembly or pump shaft. ▪ Fluctuating dynamic balance of outer magnet assembly. ▪ Impeller is in contact with inner magnet assembly anchoring section. ▪ Wear of motor bearing. 	<ul style="list-style-type: none"> <input type="checkbox"/> Repeat installation process again. <input type="checkbox"/> Retighten bolt. <input type="checkbox"/> Clean, eliminate cause of cavitation. <input type="checkbox"/> Replace. <input type="checkbox"/> Replace. <input type="checkbox"/> Remove or replace. <input type="checkbox"/> Remove or replace. <input type="checkbox"/> Replace bearing or motor.

9 Parts Description and Exploded View

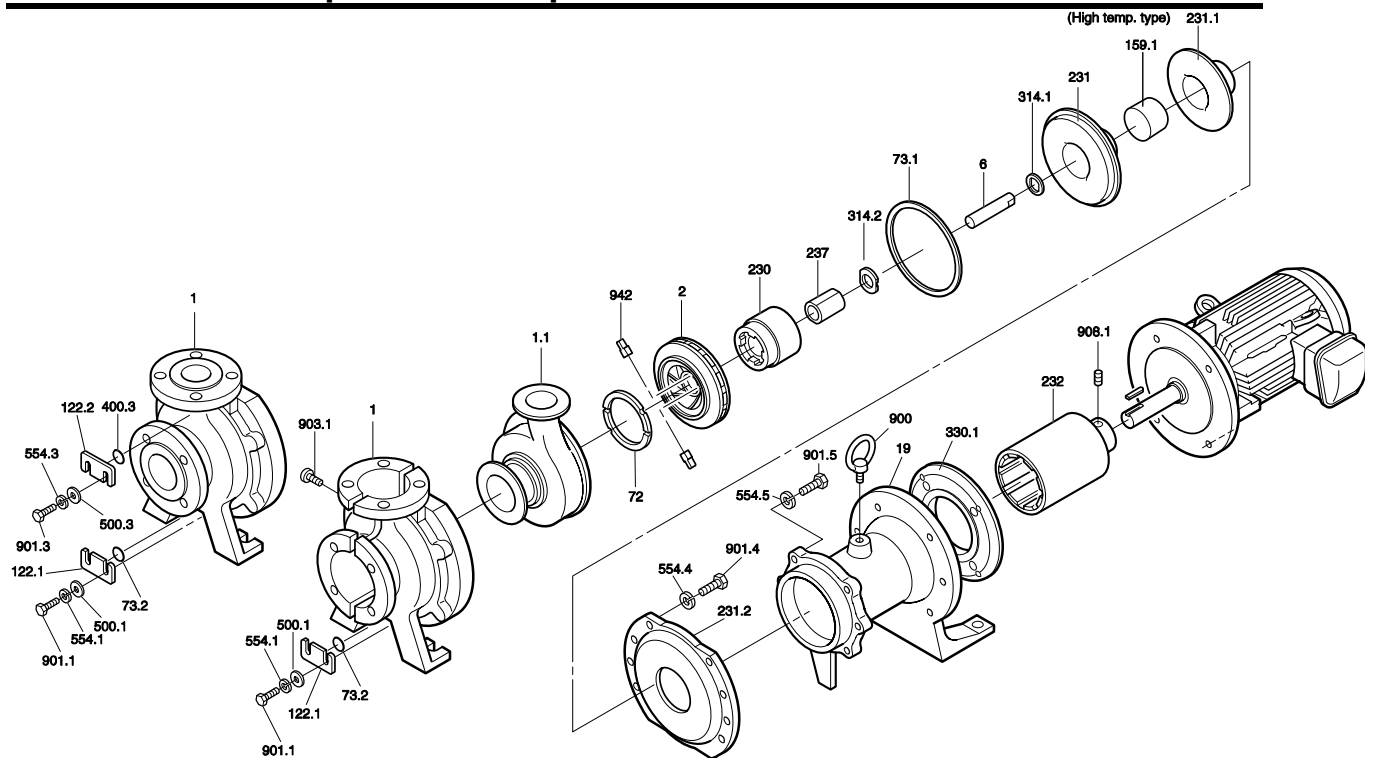

No.	Description	Qty	No.	Description	Qty
1	Casing cover	1	330.1	Motor adapter	1
1 & 1.1	Casing cover w/PFA liner & front outboard thrust collar	1	500.1	Flat washer	2
1.1	Casing liner w/front outboard thrust collar	1	500.3	Flat washer (PFA only)	2
2	Impeller	1	554.1	Split washer	2
6	Shaft	1	554.3	Split washer (PFA only)	2
19	Frame	1	554.4	Split washer	6 or 8
72	Front inboard thrust collar	1			
73.1	Casing gasket	1	554.5	Split washer	4
73.2	Drain gasket	1	554.6	Split washer	4
73.3	Air vent gasket (PFA only)	1	900	Eye bolt	1
122.1	Drain plate	1	901.1	Hex head bolt	2
122.2	Air vent plate (PFA only)	2	901.3	Hex head bolt (PFA only)	2
159.1	Support	1	901.4	Hex head bolt	6 or 8
230	Magnet capsule	1	901.5	Hex head bolt	4
231	Containment shell	1	901.6	Hex head bolt	4
231.1	Containment shell cover	1	903.1	Hex socket cap bolt	5
231.2	Containment shell support	1	903.2	Hex socket cap bolt	4
232	Outer magnet assembly	1	908.1	Hex socket set screw	2
237	Bearing	1	942	Impeller pin	2
314.1	Rear thrust collar, outboard	1			
314.2	Rear thrust collar, inboard	1			

10 Disassembly and Assembly of Pump



Caution!

Since the magnets used in the pump are powerful, be careful not to catch your fingers or hand between them during disassembly or assembly. Also, keep the magnet unit away from any electronic device that could be affected by a strong magnetic field.

Prior to servicing, the suction and discharge valves must be closed. The piping and the pump often retain some liquid. It is recommended the piping and pump cavity be drained prior to servicing.

If dangerous liquid is used, wear protection and flush pump with clean water or decontaminate prior to service.

Make sure power to motor is OFF.

■ **Disassembly**

1. Remove the drain hex bolts and flange covers, (in case of PFA type vent cover as well - (122.1)) to discharge the liquid from the pump. Flush the inside of the pump with a neutralizing fluid.

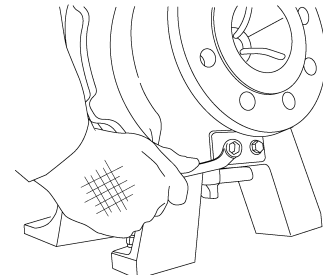

2. Remove the hex head bolts (901.5) to separate frame (330) from front pump liquid end. Take care to pull casing straight forward to prevent drive magnet (232) from damaging the rear casing cover (159)

Note: Frame may also be removed by use of two jack screws $\frac{1}{2}$ -13 UNC x 4" ($\frac{1}{2}$ -13 UNC x 2" for MDM 1516) from motor side of pump. Thread two bolts through frame, one on each side of casing. Alternate from side to side to jack front casing off frame evenly.

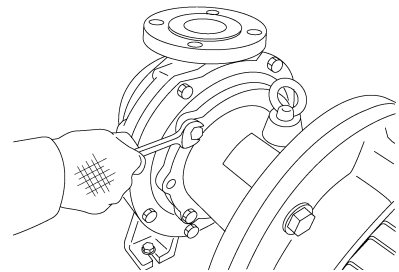

3. Remove hex bolts (901.4) of casing cover (100.2) to separate rear casing holder.

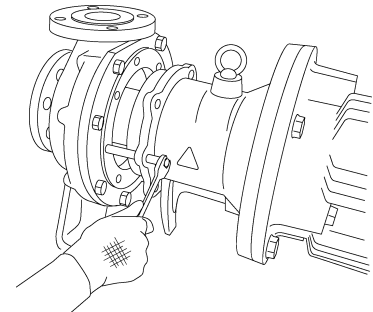
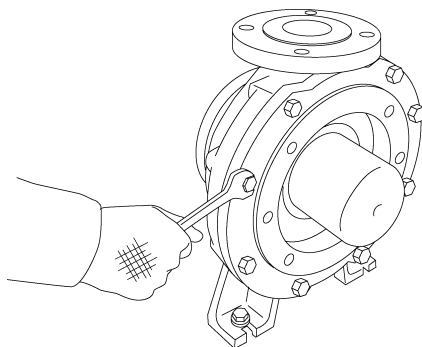

Remove containment shell cover (231.1) and containment shell (231) from liquid end assembly. If casing is difficult to remove rotate slightly as you pull it from the front casing. Take care not to drop the impeller (2) and inner magnet (230) assembly as they will come out with the containment shell and pump shaft (6).

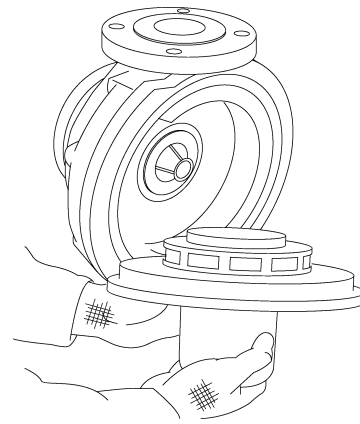

5. Remove the outer magnet assembly.

MDM1516 - MDM326 models

Remove the outer magnet by separating the motor from the frame (330.1 / 19). Stand the motor upright and remove the two M4 hex head socket set screws. Apply a pry bar to the boss of the outer magnet assembly and pull or lever the unit upwards. Store the outer magnet assembly in a proper place so that no metal pieces, etc. are attracted to it.



Caution! Do not strike the outer magnet assembly. Direct impact may loosen the magnet strips or damage the motor bearings.

■ **Replacement of rear thrust collar, radial bearing, impeller.**

Bushing:

1. Stand up two weld tabs on rear thrust collar (314.1) using plastic welder or industrial dryer. Then using a hand (arbor) press, and jig (34 mm dia. x 100 mm length, 24 mm dia. x 80 mm length for MDM1516), remove the bushing (237) by pressing the replacement jig on it from the impeller side and remove the rear inboard thrust collar (314.2).

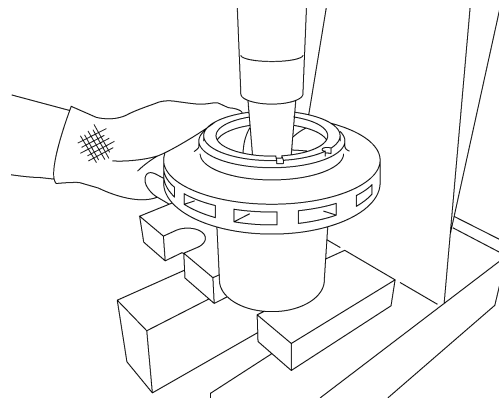
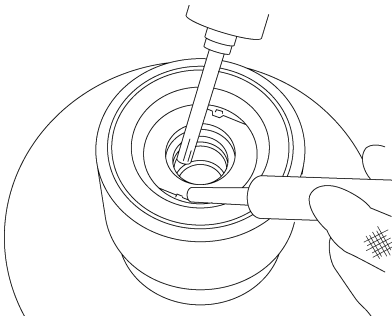

2. Remove impeller pins (942) from upper part of inner magnet by pressing pins in from the outside using a screwdriver or similar tool.

Note: H version has welded impeller and magnet capsule. Entire unit will need to be replaced.

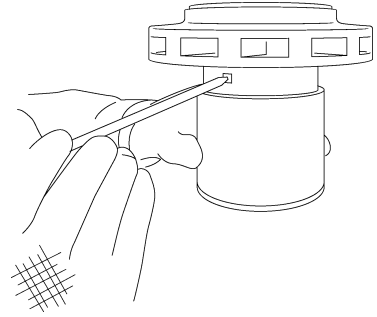

3. Remove impeller (2) from the inner magnet. If it is difficult to separate the two pieces softly strike the back shroud of the impeller while securing the inner magnet.

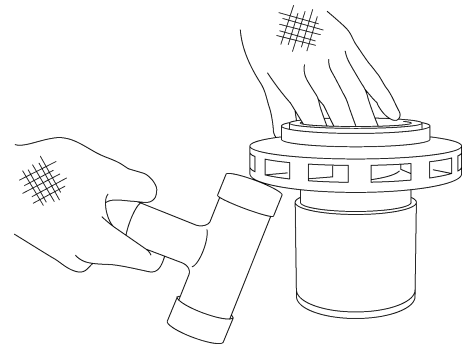

Front Inboard Thrust Collar

1. Heat two sections of the impeller locking tabs for the inboard thrust collar using a hot gas welding machine or industrial dryer at 356-392°F (180-200°C). Remove the front inboard thrust collar (72) with a flat tip screwdriver by lifting upwards. Be sure not to exceed the recommended temperature. Excessively high temperature may result in deformation of the impeller and/or inboard thrust collar.
2. Place a new front inboard thrust collar into the impeller by aligning the recessed areas of the thrust collar with the mating surfaces of the impeller and press securely into place. Ensure that the thrust collar is completely seated against the recess in the impeller.
3. Secure the inboard thrust collar utilizing the two sections of the impeller locking tabs. Heat the locking tabs at the same temperature as that of the welding rod for secure welding. Ensure that the welding points are lower than the surface of the thrust collar.

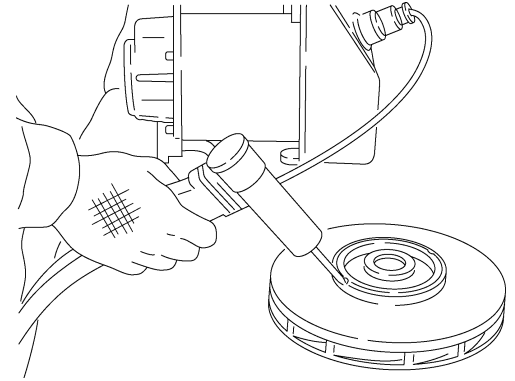

Shaft

1. The shaft (6) is slightly pressed into the containment shell (231). Pay attention to the following point when replacing the shaft.
 - If the shaft does not come off easily, warm the containment shell in hot water about 194°F (90°C) before pulling it out for replacement.
2. Holding the worn shaft in one hand and containment shell in the other, rock the shaft slightly as you pull them apart. If it is difficult to separate the parts by hand hold onto shaft and lightly tap the perimeter of the containment shell evenly with a resin hammer. Slowly withdraw the shaft while tapping. *Never strike the shaft or the seal surface of the containment shell.*
3. Clean any foreign matter or build-up on the containment shell. Align and insert the shaft into the containment shell by hand. Use a hand press if shaft is difficult to insert into the containment shell.

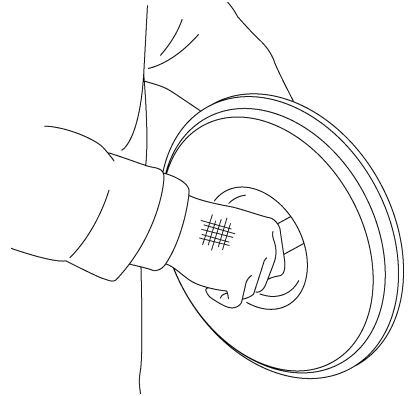

Front Casing Liner:

1. Remove the drain (122.1) and vent (122.2 (PFA Type only)) flange covers.
2. Remove the five hex socket head bolts (903.1).
3. Detach the front casing cover halves (1) from casing liner (1.1). If this is difficult due to corrosion or rust on the covers, use a resin hammer and gently tap the edge of the casing covers. *Never strike the shaft or the seal surface of the rear casing*
4. Align and install a new front casing liner into covers. If the front casing liner is difficult to attach, tap the covers gently with a resin hammer until machined surfaces are tight around casing liner.
5. Secure all hex socket bolts tightly (refer to torque table for tightening Specifications).
6. Insert gasket (73.2) into the drain and drain plate covers (122.1) prior to installing them. Tighten vent and drain cover hex bolts.

■ Reassembly

Reassemble the pump by reversing the order of disassembly. Refer to the exploded view diagram on page 24 for parts and locations. Pay attention to the following points:

- Replacement of gasket
When reassembling pump, always replace the gaskets. In addition, confirm that the gaskets are not twisted or pinched by another part.
The sealing section should be cleaned free of dust or scratches before installation.
- Fastening of bolts
Fasten the casing cover bolts in a diagonal order, applying an equal torque to each.

MDM Model	Type	Fastening Torque			Size of Bolt
		Nm	Kgf/m	Lbf/in	
1516	Hex head bolt for casing cover	58	599	520	½-13 x 1½
1518, 1518-2, 2156, 2158, 2526, 326		85	866	752	½-13 x 1¼
ALL	Hex head bolt for drain/vent	9.9	101	87.6	5/16 – 18 x ¾

Note: MDM1518-2 and 2158 use 5/8 – 11 x 1¾ bolts.

- Use the following table for correct placement of the drive magnet.

HP	ID Mark	“H” Size in
2	DN2	4.487
3	DN3	7.605
5	DN5	7.009
7-10	DN7/10	7.654
15-20	DNIS/ISS	7.701
25	DN25	8.681

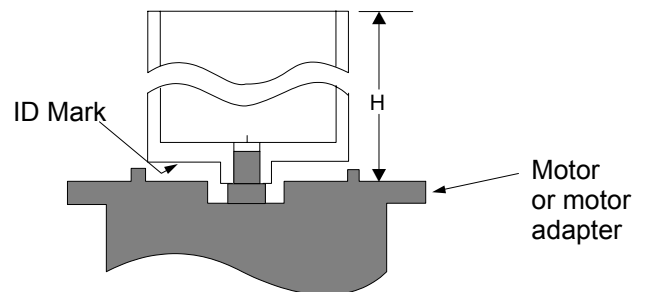

1. Mount and secure the outer magnet (232) to the motor shaft. (See drawing above)
*Note: Use Loctite 242 (threadlocker) and torque the set screws (908.1) to 8.7 ft-lbs. Confirm that there are no metal pieces or other matter adhering to the outer magnet.
2. Mount and bolt the frame (330.1) to the motor.

3. Place new gasket (73.1) into assembled front casing/liner. Make sure surfaces are clean and free from foreign material.

4. Align and attach the impeller (2) with front inboard thrust collar (72) onto the inner magnet (230). Ensure that the impeller has bottomed within the inner magnet assembly and the impeller securing ports are aligned. Insert impeller pins (942). Use needle nose pliers to correctly position pins in impeller and inner magnet assembly.

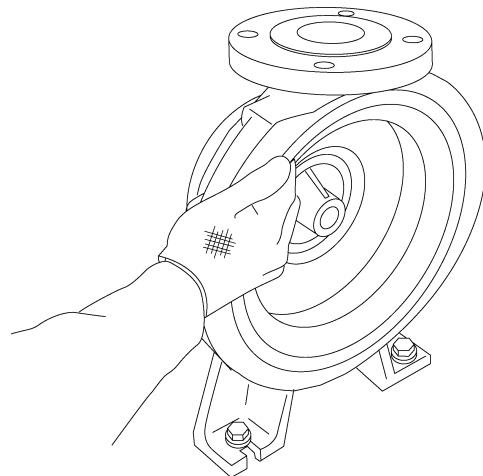

5. Heat the inner magnet/impeller assembly in warm water or oven to 194 °F (90°C) Place the assembly impeller side down on arbor press and insert bearing using replacement jig. Insert inboard thrust collar and using plastic welder or industrial dryer to weld heat tabs and secure collar in place. Note: Impeller and magnet capsule are welded together on high temperature versions.

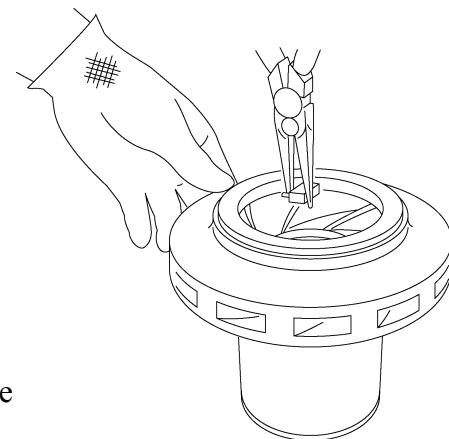

6. Clean any foreign matter or build-up on the containment shell. Align and insert the shaft into the containment shell by hand. Use a hand press if shaft is difficult to insert into the containment shell.

7. Confirm that there are no metal pieces or other matter adhering to the inner magnet. Insert the inner magnet with impeller slowly into the containment shell.

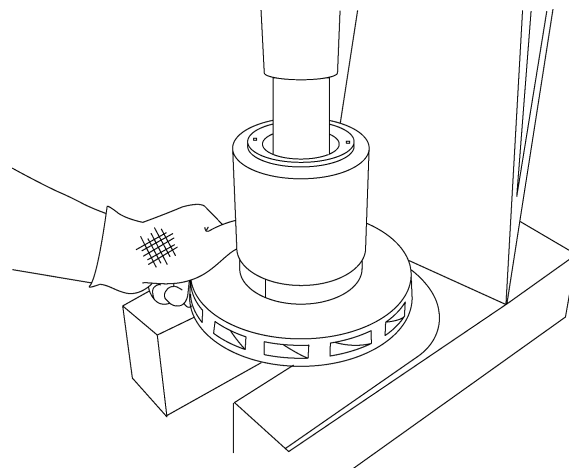

8. Place impeller/inner magnet assembly onto the shaft in the containment shell (158). Align front of shaft with support in front casing liner and slowly rotate containment shell while pushing the two assemblies together.
9. Mount the containment shell cover (159) on the containment shell and place rear casing support (161). Secure casing support by tightening hex bolts (901.4) in diagonal pattern (refer to torque table).
10. Insert liquid end assembly into frame taking care to align it such that drive magnet does not contact rear casing. Use jack bolts (threaded about half-way through frame) to ease two assemblies together.



Caution! The magnetic force is very strong. Ensure that your fingers or hands do not get caught between the liquid end assembly and frame.



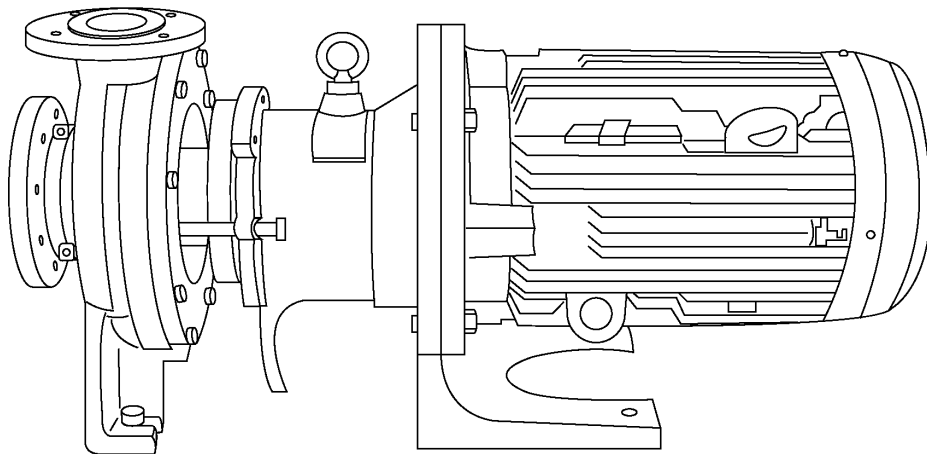



11. Fasten the hex socket bolts (901.5) in a diagonal order applying equal torque to each (refer to torque table).



11 Spare Parts

Appropriate spare parts are necessary to ensure continued pump operation. Expendable parts, such as bushings, shaft and outer thrust collar, should always be kept on hand. When placing orders, supply the following information.

1. Description and item number (according to this instruction manual).
2. Pump model number and serial number (as shown on the nameplate of the pump).
3. Drawing number if you have received a certified drawing.

NO.	Parts name	Material	Sketch	Q'ty/unit	Remarks
237	Bearing	ECF : High density carbon EKK/PKK : SIC		1	
72	Front Inboard thrust collar	ECF : PTFE EKK/PKK : SIC		1	
73.1	Gasket	PTFE		1	PTFE covered
314.1	Outboard rear thrust collar	Filler charged PTFE		1	
314.2	Inboard rear thrust collar	ECF : High purity alumina ceramic EKK/PKK : SIC		1	
73.2	Drain gasket	PTFE		1	With drain type
73.3	Air vent gasket	PTFE		1	With drain type of PFA material

12 Dimensions

MDM1516 to 2526, 2 -5 HP

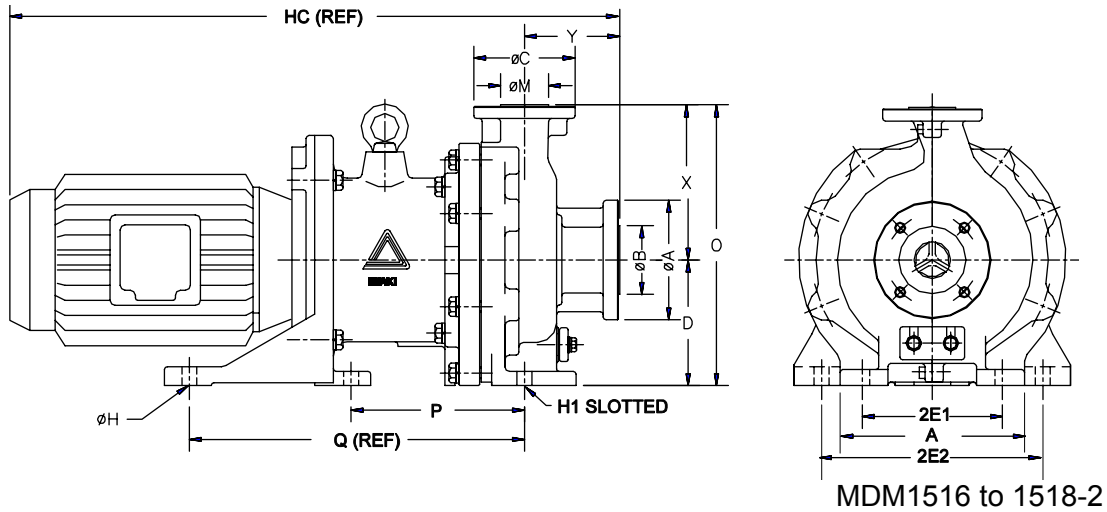

Dimensions in inches (mm)

*Meet ANSI B73.3M dimensional standards

Model	HP/Frame	HC	D	2E1	2E2	A	Q	P	G	H	H1	O	X	Y	Weight w/o Motor (lbs)
1516*	145TC	20.58 (522.7)	5.25 (133)	5.98 (151.9)	9.45 (240.3)	11.42 (290)	9.25 (234.9)	7.25 (184.2)	---	0.63 (16)	0.63 (16)	11.76 (298.7)	6.5 (165.1)	4.0 (101.6)	100
	182TC	29.0 (736.6)	5.25 (133)	5.98 (151.9)	9.45 (240.3)	7.87 (199.9)	14.09 (357.9)	7.25 (184.2)	---	0.63 (16)	0.63 (16)	11.76 (298.7)	6.5 (165.1)	4.0 (101.6)	100
1518*	184TC	30.0 (762)	5.25 (133.3)	5.98 (151.9)	9.45 (240.3)	7.87 (199.9)	14.09 (357.9)	7.25 (184.2)	---	0.63 (16)	0.63 (16)	11.76 (298.7)	6.5 (165.1)	4.0 (101.6)	132
	213-215TC	33.5 (850.9)	5.25 (133.3)	5.98 (151.9)	---	7.87 (199.9)	14.07 (357.4)	4.09 (103.9)	---	0.63 (16)	0.63 (16)	11.76 (298.7)	6.5 (165.1)	4.0 (101.6)	132
1518-2*	213-215TC	29.5 (749.3)	5.25 (133.3)	6.0 (152.4)	---	8.66 (219.9)	14.46 (367.3)	4.09 (103.9)	---	---	0.55 (13.9)	11.76 (298.7)	6.5 (165.1)	4.0 (101.6)	143
	254-256TC	33.5 (850.9)	6.25 (158.7)	6.0 (152.4)	---	9.84 (249.9)	14.97 (380.2)	4.09 (103.9)	---	---	0.55 (13.9)	12.75 (323.8)	6.5 (165.1)	4.0 (101.6)	154
	284TSC	37.35 (948.7)	7.00 (177.8)	6.0 (152.4)	---	9.84 (249.9)	14.97 (380.2)	4.09 (103.9)	0.75 (19)	---	0.55 (13.9)	13.50 (342.9)	6.5 (165.1)	4.0 (101.6)	154

For individual certified dimensional drawings, call Iwaki America or visit the Literature section on www.iwakiamerica.com.

MDM1518 to 326, 7.5 – 25 HP

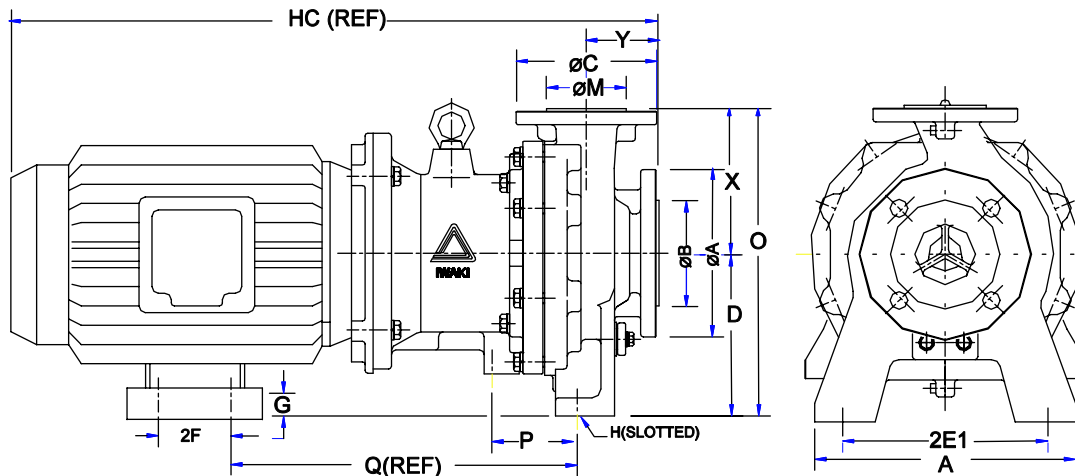

MDM2156 to 326

Dimensions in inches (mm)

*Meet ANSI B73.3M dimensional standards

Model	Frame	HC	D	2E1	2E2	A	Q	P	G	H	H1	O	X	Y	Weight w/o Motor (lbs)
2156	184TC	29 (736.6)	7.09 (180)	8.66 (219.9)	---	11.02 (279.9)	13.68 (347.5)	6.89 (175)	1.83 (46.5)	0.63 (16)	0.55 (13.9)	13.39 (340.1)	6.3 (160)	3.15 (80)	132
	213-215TC	31 (787.4)	7.09 (180)	8.66 (219.9)	11.02 (279.9)	11.02 (279.9)	14.45 (387)	3.70 (93.9)	3.54 (89.9)	0.55 (13.9)	0.38 (9.6)	13.39 (340.1)	6.3 (160)	3.15 (80)	132
2158	213-215TC	28.62 (726.9)	7.00 (177.8)	8.66 (219.9)	---	11.02 (279.9)	20.07 (509.8)	3.70 (93.9)	1.75 (44.4)	---	0.55 (13.9)	14.09 (357.8)	7.09 (180)	3.15 (80)	154
	254-256TC	32.67 (829.8)	7.00 (177.8)	8.66 (219.9)	---	11.02 (279.9)	19.57 (497)	3.70 (93.9)	0.75 (19)	---	0.55 (13.9)	14.09 (357.8)	7.09 (180)	3.15 (80)	165
	284TC	36.5 (927.1)	7.00 (177.8)	8.66 (219.9)	---	11.02 (279.9)	20.27 (514.8)	3.58 (90.9)	---	---	0.55 (13.9)	14.09 (357.8)	7.09 (180)	3.15 (80)	165
2526	184TC	29 (736.6)	7.09 (180)	8.66 (219.9)	11.02 (279.9)	---	13.68 (347.5)	6.89 (175)	1.83 (46.5)	0.38 (9.6)	0.55 (13.9)	13.39 (340.1)	6.3 (160)	3.15 (80)	132
	213-215TC	31 (784.4)	7.09 (180)	8.66 (219.9)	11.02 (279.9)	---	14.45 (367)	3.70 (93.98)	3.54 (89.9)	0.55 (13.9)	0.38 (9.6)	13.39 (340.1)	6.3 (160)	3.15 (80)	132
326	213-215TC	31 (784.4)	8.25 (209.5)	9.76 (247.9)	---	11.81 (299.9)	14.47 (367.5)	4.09 (103.9)	2.99 (75.9)	0.63 (16)	---	16.5 (419.1)	8.25 (209.5)	4.0 (101.6)	144
	254-256TC	36 (914.4)	8.25 (209.5)	9.76 (247.9)	---	11.81 (299.9)	14.97 (380.2)	4.09 (103.9)	1.99 (50.5)	0.63 (16)	---	16.5 (419.1)	8.25 (209.5)	4.0 (101.6)	144
	284TSC	37.35 (948.7)	8.25 (209.5)	9.76 (247.9)	---	11.81 (299.9)	14.97 (380.2)	4.09 (103.9)	1.25 (31.8)	0.63 (16)	---	16.5 (419.1)	8.25 (209.5)	4.0 (101.6)	144

For individual certified dimensional drawings, call Iwaki America or visit the Literature section on www.iwakiamerica.com.

Iwaki America Inc.
5 Boynton Road Hopping Brook Park Holliston MA 01746-1446 USA
TEL: 508-429-1440 FAX: 508-429-1386 Website: www.IwakiAmerica.com