

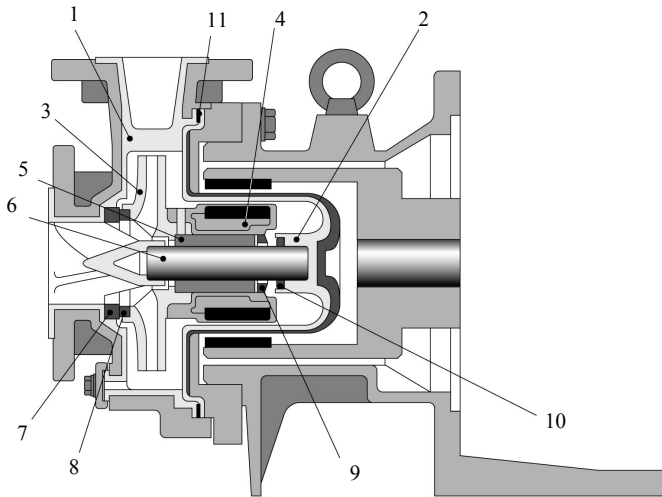

MDM-2526 5HP

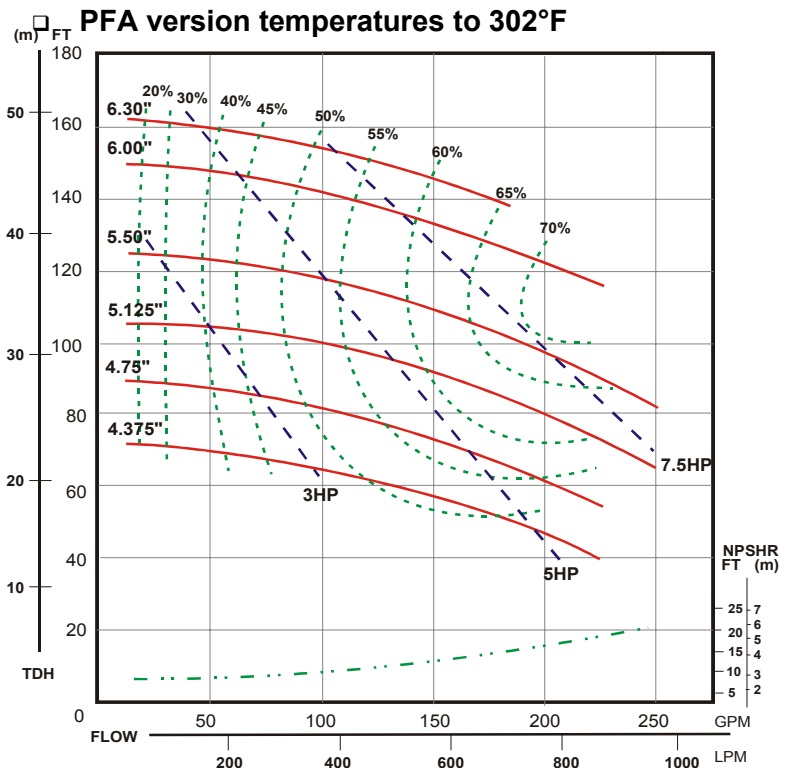

- ❑ Non-contact Bearing System allows dry run operation (CF models only)
- ❑ Simple, rugged design
- ❑ Corrosion resistant ETFE & PFA internals
- ❑ Spline/pinned impeller design (pat. pending) provides positive locking of impeller/inner magnet while still allowing for individual replacement of each part



Part	Material		
	ECF	EKK	PKK
1 Front casing	CFRETFE (carbon fiber reinforced ETFE)		PFA
2 Containment shell			
3 Impeller			
4 Inner magnet assy			
5 Bearing	High density carbon	SiC	
6 Shaft	High purity alumina ceramic		
7 Front outboard thrust collar	PTFE		
8 Front inboard thrust collar			
9 Rear inboard thrust collar	High purity alumina ceramic		
10 Rear outboard thrust collar	PTFE (filler charged)	PTFE	
11 Gasket	PTFE		

Dimensions (inches) and Specifications
Note: Will vary by motor manufacturer

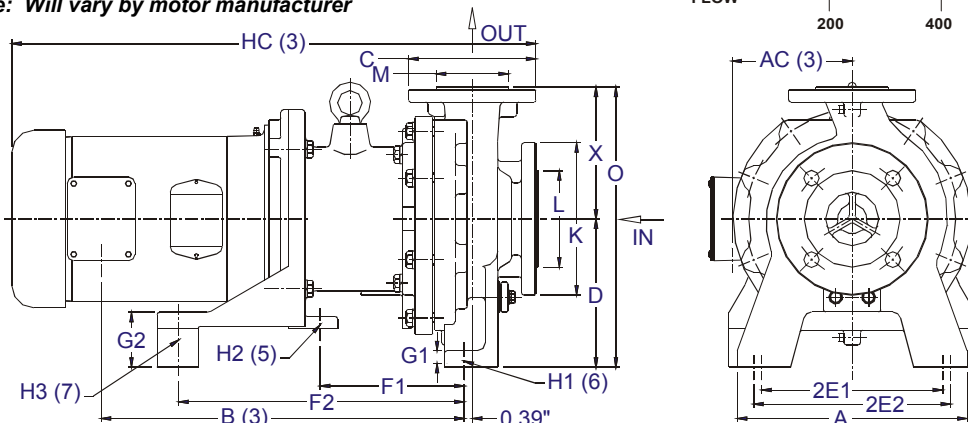

A	AC(3)	B(3)	D	2E1	2E2	F1	F2	G1	G2	H1 (6)	H2 (5)	H3	HC (3)	O	X	Y
11.02	5.76	17.41	7.09	8.66	9.45	6.89	13.68	0.60	2.62	0.55	0.63	0.63	25.13	13.39	6.50	4.00
HP/Frame		Connection Sizes		Min Flow/Max Head		Standard Capacity		Max Capacity		Pump Weight*		K	L	C	M	
5/184TC		2.5 x 2		13/162		180		260		132		7.28	4.61	6.10	3.47	

*Pump end only. Does not include motor.