

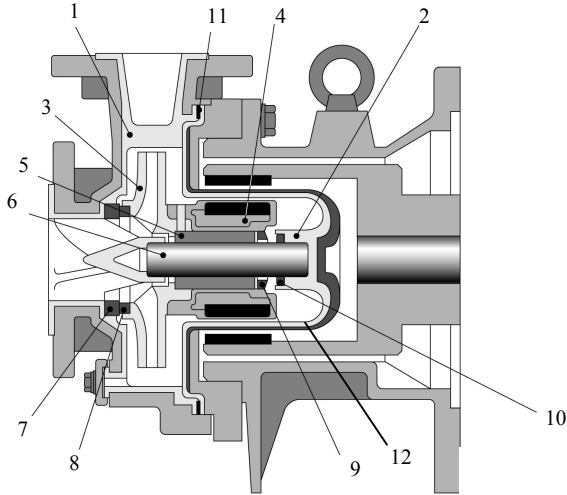

MDM-2158 7.5/10HP



- ❑ Exceeds ANSI Performance standards
- ❑ Simple, rugged, modular design
- ❑ Dual back pull-out
- ❑ Alpha sintered SiC bearing system

Part	Material	
	EKK	PKK
1 Front casing	CFRETFE (carbon fiber reinforced ETFE)	PFA
2 Containment shell		
3 Impeller		
4 Inner magnet assy		
5 Bearing	SiC	
6 Shaft		
7 Front outboard thrust collar		
8 Front inboard thrust collar		
9 Rear inboard thrust collar	PTFE (filler charged)	PTFE
10 Rear outboard thrust collar		
11 Gasket	PTFE	
12 Support	Kevlar®	

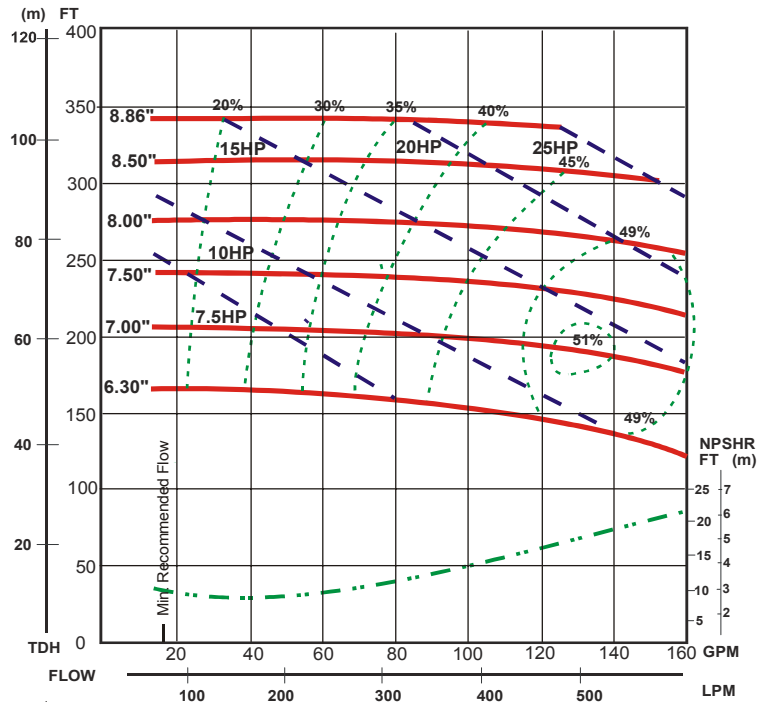

Dimensions (inches) and Specifications
Note: Will vary by motor manufacturer

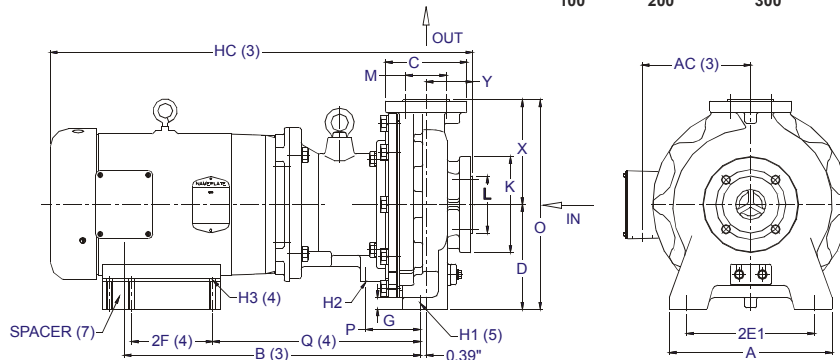

A	AC(3)	B(3)	D	2E1	2F(4)	G	H1(5)	H2	H3(4)	HC(3)	O	P	Q(4)	X	Y	
11.02	7.34	20.07	7.00	8.66	5.50/ 7.00	0.70	0.55	3/8-16UNC	0.41	28.62	14.09	3.70	14.07	7.09	3.15	
HP/Frame			Connection Sizes		Min Flow/Max Head		Standard Capacity		Max Capacity		Pump Weight		K	L	C	M
7.5/213TC & 10/215TC			2 x 1.5		13/343		125		160		154		6.50	3.86	5.51	2.75