

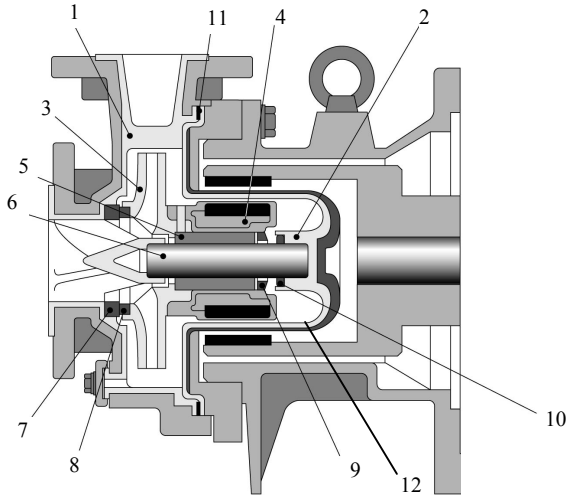

# MDM-2158 25HP



- ❑ Exceeds ANSI Performance standards
- ❑ Simple, rugged, modular design
- ❑ Dual back pull-out
- ❑ Alpha sintered SiC bearing system

| Part                           | Material                                     |      |
|--------------------------------|--|------|
|                                | EKK  | PKK  |
| 1 Front casing                 | CFRETFE<br>(carbon fiber reinforced<br>ETFE) | PFA  |
| 2 Containment shell            |  |      |
| 3 Impeller                     |  |      |
| 4 Inner magnet assy            |  |      |
| 5 Bearing                      | SiC  |      |
| 6 Shaft                        |  |      |
| 7 Front outboard thrust collar |  |      |
| 8 Front inboard thrust collar  |  |      |
| 9 Rear inboard thrust collar   |  |      |
| 10 Rear outboard thrust collar | PTFE (filler charged)                        | PTFE |
| 11 Gasket                      | PTFE   |      |
| 12 Support                     | Kevlar®                                      |      |

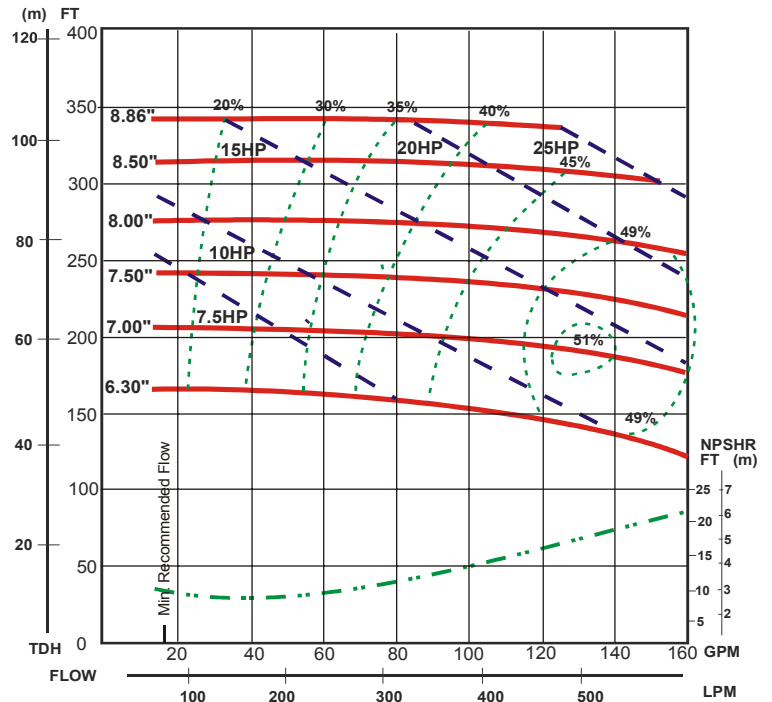

## Dimensions (inches) and Specifications

Note: Will vary by motor manufacturer

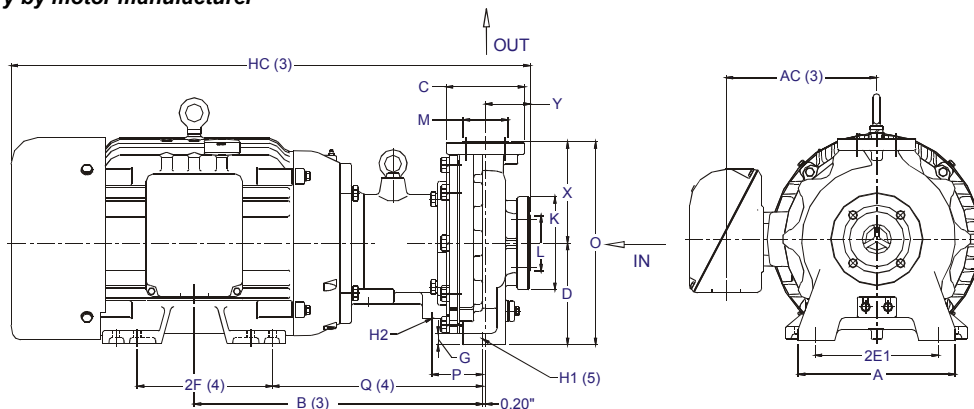

| A         | AC(3) | B(3)  | D                | 2E1  | 2F(4)             | G    | H1(5)             | H2        | H3(4)        | HC(3) | O            | P    | Q(4)  | X    | Y    |      |
|-----------|-------|-------|------------------|------|-------------------|------|-------------------|-----------|--------------|-------|--------------|------|-------|------|------|------|
| 11.02     | 10.56 | 20.27 | 7.00             | 8.66 | 9.50/11.00        | 0.70 | 0.55              | 3/8-16UNC | 0.52         | 36.50 | 14.09        | 3.58 | 14.77 | 7.09 | 3.15 |      |
| HP/Frame  |       |       | Connection Sizes |      | Min Flow/Max Head |      | Standard Capacity |           | Max Capacity |       | Pump Weight* |      | K     | L    | C    | M    |
| 25/284TSC |       |       | 2 x 1.5          |      | 13/343            |      | 125               |           | 160          |       | 165          |      | 6.50  | 3.86 | 5.51 | 3.15 |

\*Pump end only. Does not include motor.