

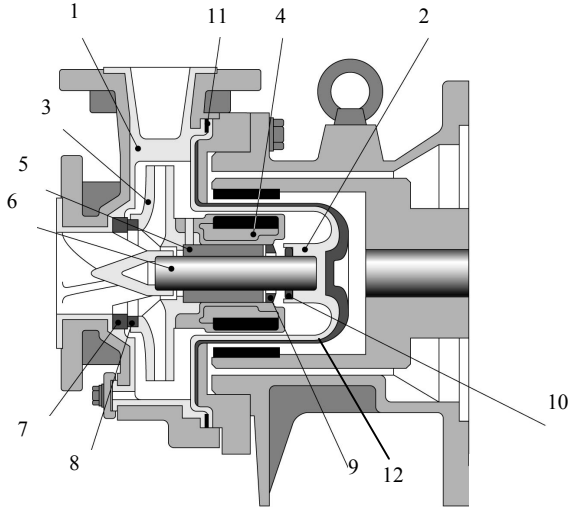

# MDM-1518-2 25HP



- ❑ Exceeds ANSI performance standards in ANSI dimensional design
- ❑ Simple, rugged, modular design
- ❑ Dual back pull-out
- ❑ Alpha sintered SiC bearing system

Part	Material	
	EKK	PKK
1 Front casing	CFRETFE (carbon fiber reinforced ETFE)	PFA
2 Containment shell		
3 Impeller		
4 Inner magnet assy		
5 Bearing	SiC	
6 Shaft		
7 Front outboard thrust collar		
8 Front inboard thrust collar		
9 Rear inboard thrust collar	PTFE (filler charged)	PTFE
10 Rear outboard thrust collar		
11 Gasket	PTFE	
12 Support	Kevlar®	

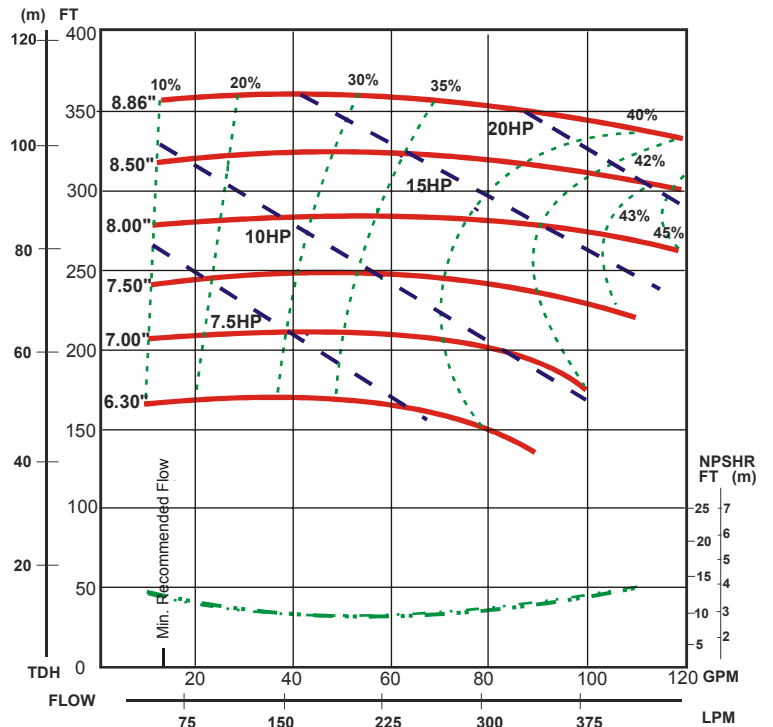

## Dimensions (inches) and Specifications

Note: Will vary by motor manufacturer

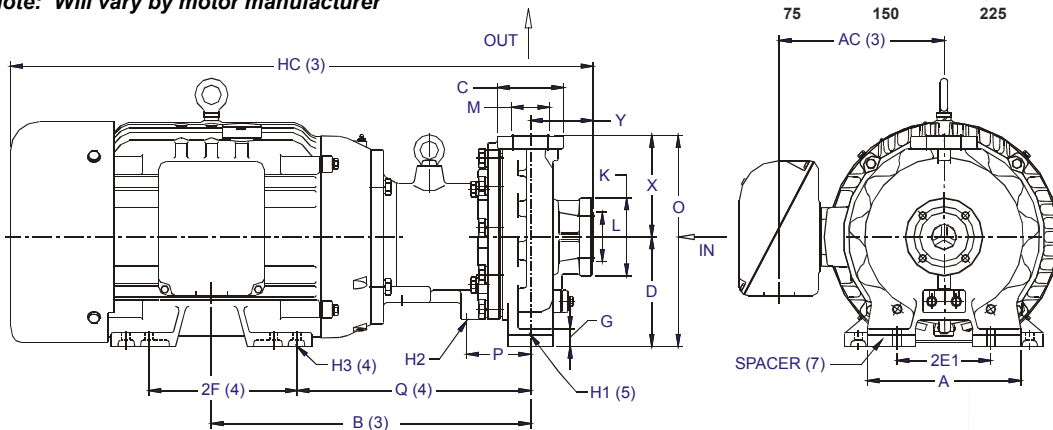

A	AC(3)	B(3)	D	2E1	2F(4)	G	H1(5)	H2	H3(4)	HC(3)	O	P	Q(4)	X	Y
9.84	10.56	20.47	7.00	6.00	9.50	1.14	0.55	3/8-16 UNC	0.52	37.35	13.50	4.09	14.97	6.50	4.00
HP/Frame		Connection Sizes		Min Flow/Max Head		Standard Capacity		Max Capacity		Pump Weight*		K	L	C	M
25/284TSC		1.5 x 1		13/360		90		120		154		5.00	3.15	4.25	2.48

\*Pump end only. Does not include motor.

IF20527.A 8/04

5 BOYNTON ROAD HOPPING BROOK PARK HOLLISTON, MA 01746-1446 USA  
 TEL: 508-429-1440 FAX: 508-429-1386 WEBSITE: [WWW.IWAKIAMERICA.COM](http://WWW.IWAKIAMERICA.COM)