

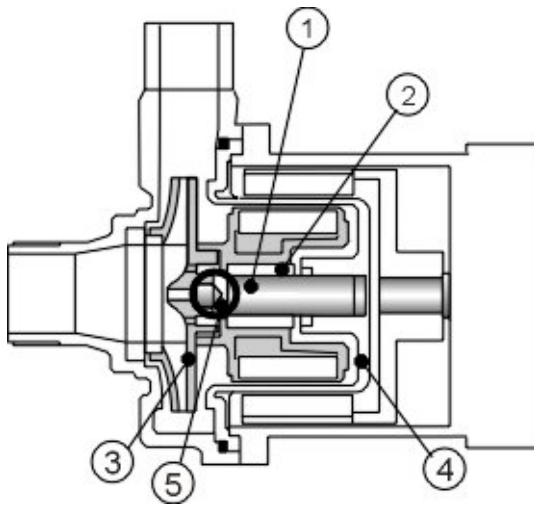

IWAKI WALCHEM Corporation

MDH-F400



- Patented Pinpoint Bearing System allows dry run operation (with CV models only)
- Flush grooves cool main bearing
- Mounts to standard NEMA motors
- Carbon fiber reinforced ETFE wetted parts

Part	Material
1 Spindle	Alumina Ceramic
2 Bearing	Alumina Ceramic, Carbon
3 Impeller	ETFE
4 Rear Casing	ETFE
5 Pinpoint Bearing System	Alumina Ceramic, Carbon

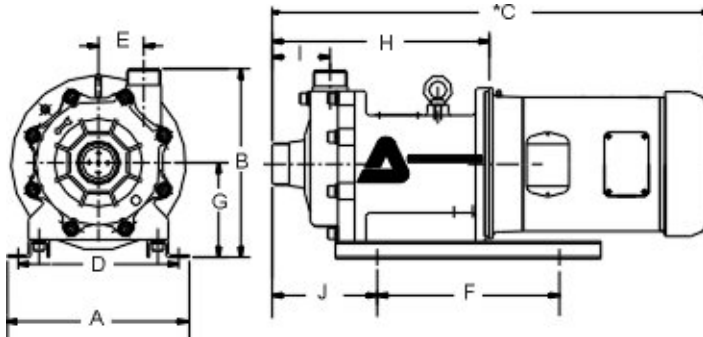
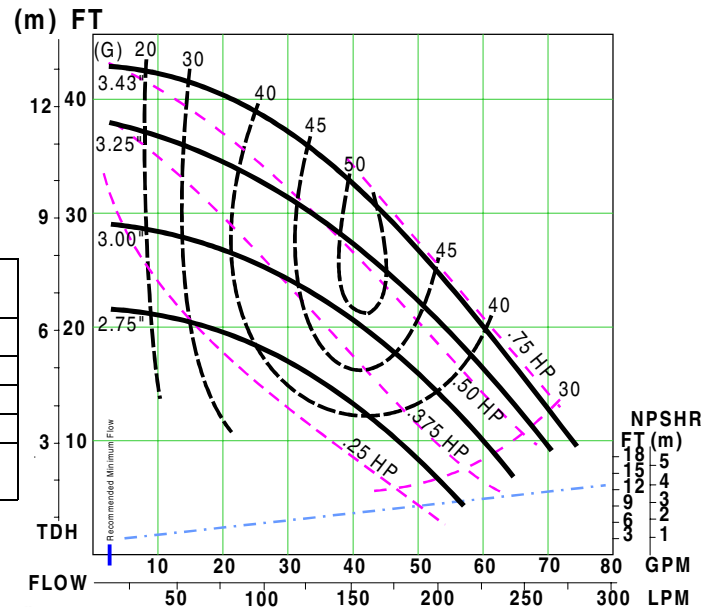

Dimensions (inches) and Specifications

** Will vary by motor manufacturer*

MODEL	MOTOR HP	NEMA	A	B	C	D	E	F	G	H	I	J
MDH-F400	1/2	56C	5.51	8.27	18	4.33	2.01	3.86	3.74	8.75	3.19	5.67
MDH-F400-G	3/4											

MODEL	CONNECTIONS		MOTOR OUTPUT (hp)	MOTOR SPEED (rpm)	MAX. FLOW (gpm)	MAX. HEAD (ft)	MAX. WORKING PRESSURE (psi)	S.G.	WEIGHT PUMP ONLY (lbs)
	SUCT (in)	DISCH (in)							
MDH-F400-G	1.5	1.5	.75	3600	66	43	23	1.2	14