

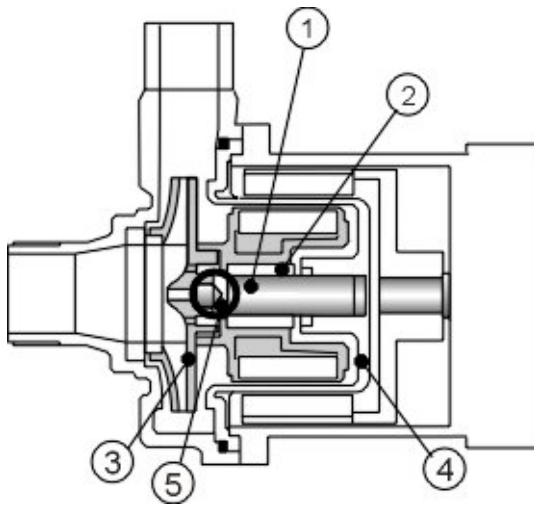

IWAKI WALCHEM Corporation

MDH-401-6



- Patented Pinpoint Bearing System allows dry run operation (with CV models only)
- Flush grooves cool main bearing
- Mounts to standard NEMA motors
- Glass fiber reinforced polypropylene wetted parts

Part	Material
1 Spindle	Alumina Ceramic, 316 SS
2 Bearing	Carbon, PTFE
3 Impeller	GFRPP
4 Rear Casing	GFRPP
5 Pinpoint Bearing System	Alumina Ceramic, Carbon

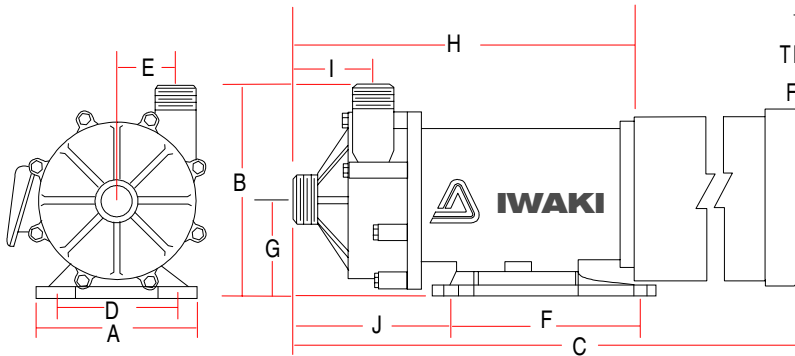
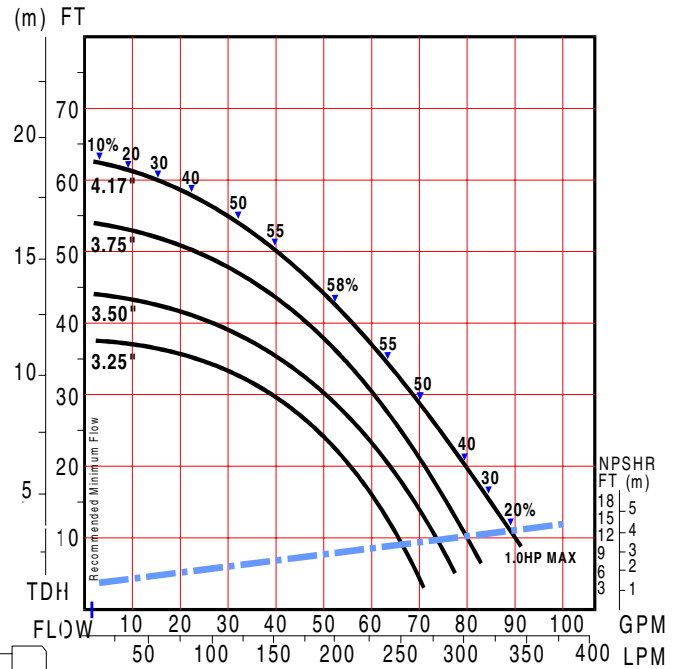

Dimensions (inches) and Specifications

** Will vary by motor manufacturer*

HP	NEMA	A	B	C*	D	E	F	G	H	I	J
1	56C	6.30	9.76	20.75	5.12	2.26	5.12	4.53	11.50	3.84	7.01
Connection Sizes	Motor Output (hp)	Motor Speed (rpm)	Max Flow (gpm)	Max Head (ft)	Working Pressure (psi)	Specific Gravity	Weight Pump Only (lbs)				
1½ x 1½	1	3600	85.5	62	34	1.1	24				