



EHE Series Electronic Metering Pump Instruction Manual

W A L C H E M

Five Boynton Road Hopping Brook Park Holliston, MA 01746 USA TEL 508-429-1110 FAX 508-429-7433

Website: www.walchem.com

Notice

© 2002 WALCHEM Corporation
Five Boynton Road, Holliston, MA 01746 USA
tel (508) 429-1110 fax (508) 429-7433
All Rights Reserved
Printed in USA

Proprietary Material

The information and descriptions contained herein are the property of WALCHEM Corporation. Such information and descriptions may not be copied or reproduced by any means, or disseminated or distributed without the express prior written permission of WALCHEM Corporation.

This document is for information purposes only and is subject to change without notice.

Statement of Limited Warranty

WALCHEM Corporation warrants equipment of its manufacture and bearing its identification to be free from defects in workmanship and material for a period of two years from date of delivery from the factory or authorized distributor under normal use and service and otherwise when such equipment is used in accordance with instructions furnished by WALCHEM Corporation and for the purposes disclosed in writing at the time purchased, if any.

WALCHEM Corporation's liability under this warranty shall be limited to replacement or repair, F.O.B. Holliston, MA U.S.A. of any defective equipment or part which, having been returned to WALCHEM Corporation, transportation charges prepaid, has been inspected and determined by WALCHEM Corporation to be defective.

THIS WARRANTY IS IN LIEU OF ANY OTHER WARRANTY, EITHER EXPRESS OR IMPLIED, AS TO DESCRIPTION, QUALITY, MERCHANTABILITY, FITNESS FOR ANY PARTICULAR PURPOSE OR USE, OR ANY OTHER MATTER.

*P/N E00022.E
April, 2002*

TABLE OF CONTENTS

Thank you for choosing a Walchem EH Series metering pump. This instruction manual deals with the correct installation, operation, maintenance and troubleshooting procedures for the EHE model metering pumps. Please read through it carefully to ensure the optimum performance, safety and service of your pump.

1.0	INTRODUCTION	1
1.1	Safety and Caution Notes	1
1.2	Principle of Operation.....	1
1.3	Specifications.....	2
1.4	Dimensions	3
2.0	INSTALLATION.....	4
2.1	Unpacking.....	4
2.2	Location	4
2.3	Supply Tubing.....	6
2.4	Discharge Tubing.....	6
2.5	Installing Injection/Back Pressure Valve.....	7
2.6	Electrical	7
3.0	OPERATION.....	8
3.1	Priming.....	8
3.2	Adjustment.....	8
3.3	Calibration.....	8
3.4	External Control	9
3.5	STOP Function	15
3.6	AC Power Interruption.....	15
4.0	MAINTENANCE.....	16
4.1	Diaphragm Replacement	16
4.2	Valve Replacement.....	16
4.3	Tubing.....	16
5.0	EXPLODED VIEW AND PARTS GUIDE.....	17
5.1	How to order parts for your metering pump.....	17
5.2	Accessories (Not shown).....	17
5.3	EHE30, 35, 45 Liquid End Exploded View.....	18
5.4	EHE 55 Liquid End Exploded View.....	19
5.5	Drive Control Components	20
5.6	Assembly Part Numbers	21
5.7	Spare Parts Kit.....	21
6.0	TROUBLESHOOTING.....	22
7.0	SERVICE POLICY.....	23

1.0 INTRODUCTION

1.1 Safety and Caution Notes



Always wear protective clothing, eye protection and gloves before working on or near a metering pump. Follow all recommendations of the supplier of the solution being pumped. Refer to the MSDS from the solution supplier for additional precautions.

Walchem EH Series metering pumps should be installed where ambient temperatures do not exceed 122°F (50°C) or do not fall below 32°F (0°C), or where pump or tubing are directly exposed to sunlight.



WARNING Risk of electrical shock! This pump is supplied with a grounding conductor and grounding-type attachment plug. To reduce the risk of electrical shock, be certain that it is connected only to a properly grounded, grounding type receptacle with ratings conforming to the data on the pump data plate. Prior to performing any maintenance on a pump, disconnect the pump from the electrical power source.



Plumbing Precautions

All tubing must be securely attached to the fittings prior to starting the pump (see Section 2.3). Only use Walchem tubing with your pump. Tubing should be shielded to prevent possible injury in case of rupture or damage. UV resistant tubing should be used if the tubing is exposed to UV light. Always adhere to local plumbing codes and requirements. Be sure that the installation does not constitute a cross connection. Walchem is not responsible for improper installations. Prior to performing any maintenance on a pump, depressurize the discharge tubing.

If you are pumping downhill or into little or no system pressure, a back pressure/anti-siphon device must be installed to prevent over-pumping. Contact your Walchem distributor for additional information.



Solution Compatibility

CAUTION! This pump has been tested by Underwriters Laboratories Inc. using water only. The suitability of this pump for use with liquids other than water is the responsibility of the user. For liquids other than water, select the best-suited liquid end material combination using a chemical compatibility chart.

1.2 Principle of Operation

The EH Series electronic metering pump consists of a pump unit, a drive unit, and a control unit. The drive unit is an electromagnetic solenoid. When the solenoid coil is energized by the control unit the armature shaft moves forward due to the magnetic force of the solenoid. The shaft is attached to a PTFE faced diaphragm which is part of the pump unit. The diaphragm is forced into the pump head cavity decreasing volume and increasing pressure which forces liquid in the pump head out through the discharge check valves. When the solenoid coil is de-energized, a spring returns the armature to its starting position. This action pulls the diaphragm out of the head cavity increasing volume and decreasing pressure. Atmospheric pressure then pushes liquid from the supply tank through the suction check valves to refill the pump head.

1.3 Specifications

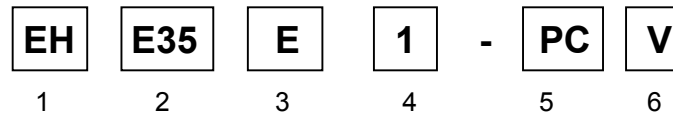

1 Pump Series

EHE Electronic metering pump with external pulse control or manual speed control (adjustable to 360 strokes per minute) and manually adjustable stroke length. (Typical turndown ratio 1800:1.)

2 Capacity/Pressure Rating

Size	Output Capacity				Output per stroke (mL)		Maximum Pressure		Conn. Size (in) Tubing O.D.
	(GPH)		(mL/min)		min	max	(PSI)	(MPa)	
	min	max	min	max					
E30	0.0031	5.5	0.189	340	0.189	0.94	150	1.0	½
E35	0.0047	8.5	0.289	520	0.289	1.44	105	0.7	½
E45	0.0067	12.0	0.417	750	0.417	2.08	60	0.4	½
E55	0.0111	20.0	0.694	1250	0.694	3.47	30	0.2	½

3 Control Module

E For use on all EHE models, features analog and external pulse control with pulse divide and multiply capability.

4 Voltage

1 115VAC, 50/60 Hz
2 230VAC, 50/60 Hz

5 Liquid End

Liquid End Code	Pump Head & Fittings	Diaphragm*	Valve Balls	Valve Seat	Valve Seals	Gasket	Tubing
VC	PVC	PTFE	CE	FKM	FKM	PTFE	PE
VE	PVC	PTFE	CE	EPDM	EPDM	PTFE	PE
VF	PVC	PTFE	PTFE	EPDM	EPDM	PTFE	PE
V6	PVC	PTFE	SS	EPDM	EPDM	PTFE	PE
PC	GFRPP	PTFE	CE	FKM	FKM	PTFE	PE
PE	GFRPP	PTFE	CE	EPDM	EPDM	PTFE	PE
FC	PVDF	PTFE	CE	PCTFE	PTFE	PTFE	PE
VM †	M-PVC	PTFE	CE	FKM	PTFE	PTFE	PE

† E55 Model only

* Bonded to EPDM

Materials of Construction

CE	Alumina ceramic	PCTFE	Polychlorotrifluoroethylene
EPDM	Ethylene propylene diene monomer	PE	Polyethylene
FKM	Fluoroelastomer	PTFE	Polytetrafluoroethylene
GFRPP	Glass fiber reinforced polypropylene	PVC	Polyvinylchloride (translucent)
M-PVC	Machined polyvinylchloride	PVDF	Polyvinylidene fluoride
SS	316 Stainless steel		

6 Special Head Options

Blank Standard ½" tube connection with tube style injection & foot valves.
V Standard ½" tube connection with back pressure/anti-syphon valve, tube style injection & foot valves.
T ¾" NPT (male) pipe thread connection. No accessory valves.
P ¾" NPT (male) connection with back pressure/anti-syphon valve.

Adjustment Range

Recommended stroke length adjustment range	20% to 100%
Recommended frequency adjustment range	0 to 360 strokes per minute

Operating Conditions

Ambient temperature
Relative humidity

32 to 122°F (0 to 50°C)
30 to 90% non-condensing

1.4 Dimensions

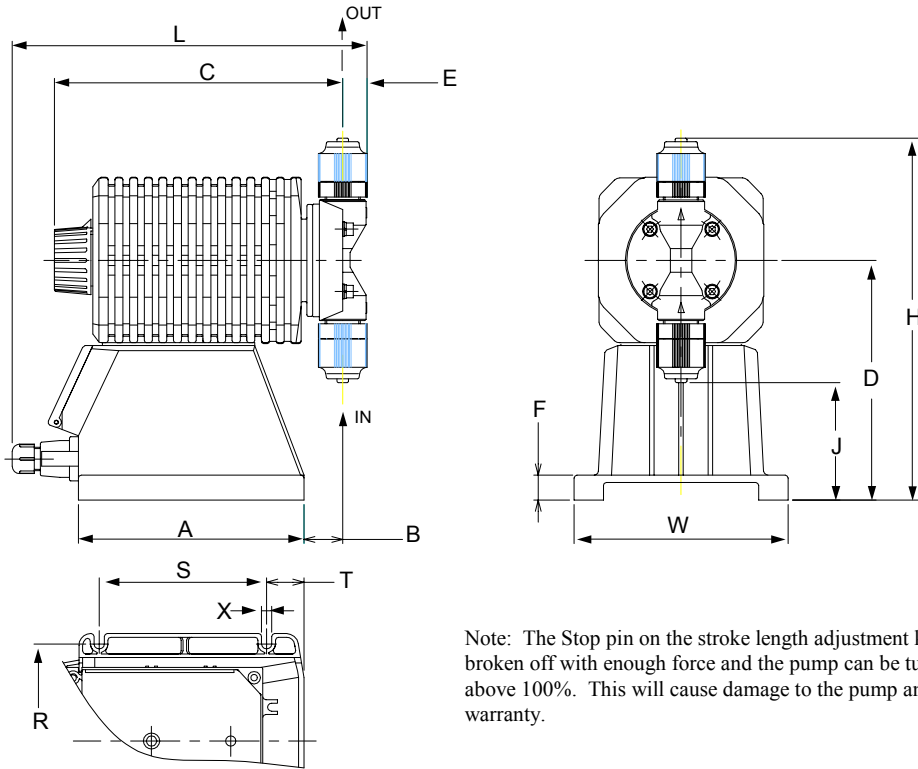

Note: The Stop pin on the stroke length adjustment knob can be broken off with enough force and the pump can be turned up above 100%. This will cause damage to the pump and void the warranty.

Model					A	B	C	D	E	F	H	J	L	W
EHE	30	E1	-VC	-VE	6.06	1.04	7.76	6.42	0.65	0.67	9.69	3.15	9.53	5.75
		E2	-PC	-PE										
			-V6	-VF										
			-FC											
EHE	45	E1	-VC	-VE	6.06	1.14	7.83	6.42	0.75	0.67	10.00	2.80	9.72	5.75
		E2	-PC	-PE										
			-V6	-VF										
			-FC											
EHE	55	E1	-VC	-VE	6.06	1.42	8.13	6.42	0.85	0.67	10.45	2.38	10.12	5.75
		E2	-PC	-PE										
			-V6	-VF										
			-FC											
EHE	55	E1	-VM		6.06	1.42	8.13	6.42	0.91	0.67	10.45	2.38	10.17	5.75
		E2												

Mounting Dimensions	R	S	T	X
EHE all variations	5.20	4.50	1.00	0.28

All dimensions in inches

2.0 INSTALLATION

2.1 Unpacking

Open the shipping carton and inspect contents for damage. If any items are missing or damaged contact your local distributor to arrange for replacement.



Pumps are pre-primed with water at the factory. If the application is not compatible with water, drain and dry before use. Be sure to remove caps from fittings before attaching tubing.



Caution: Head bolts may have loosened during storage or shipment. Be sure to check and tighten to 19 lb-in torque, if necessary.

2.2 Location

Choose a location for the pump which is clean, dry, close to an electrical outlet, and allows convenient access to stroke length control, frequency control, and tubing connections. Avoid areas where ambient temperature exceeds 122°F (50°C) or falls below 32°F (0°C), or where the pump or tubing would be exposed to direct sunlight.

This pump is cord connected and not intended for permanent mounting to a building structure. However, temporary mounting to stabilize the pump during operation may be necessary as long as tools are not required for the installation or removal of the pump.

Flooded suction (mounting the pump below the level of liquid in the supply tank) is strongly recommended, especially when pumping liquids that readily generate gas bubbles. Sodium hypochlorite and hydrogen peroxide are common examples of such liquids. (See Figure 1.)

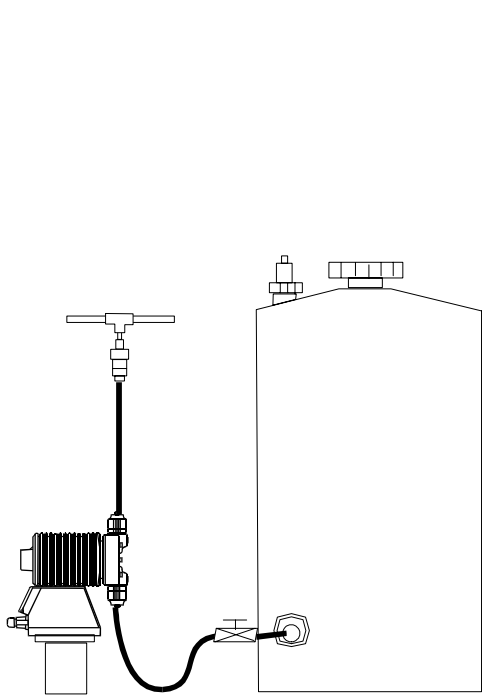

Figure 1
Flooded Suction

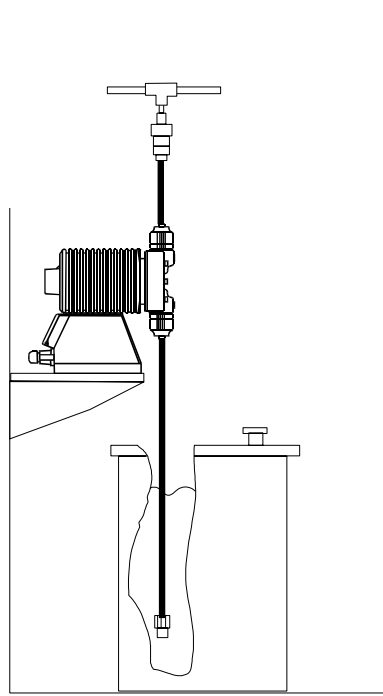

Figure 2
Shelf Mount

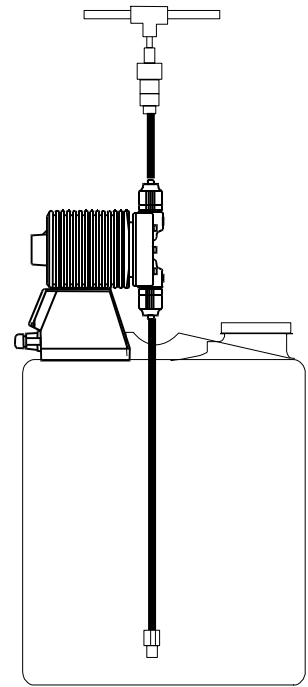

Figure 3
Tank Mount

If flooded suction mounting is not possible, a shelf adjacent to (but not directly above) the supply tank often works well (see Figure 2). The supply tank or cover can also be used if it has provisions for mounting a pump (see Figure 3). In any case, the total suction lift should not exceed 5 ft (1.5m). See Figure 4 for reference.

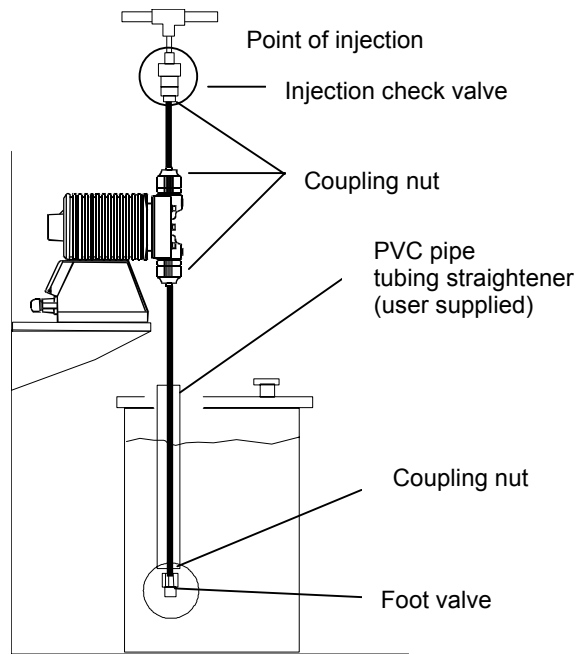

Figure 4 Connecting Tubing

2.3 Supply Tubing

The supply tubing run should be as short as possible. For flooded suction mounting, install a shut-off valve with an appropriate tubing connector at the tank outlet. Cut a length of tubing from the coil supplied and install between the shut-off valve and the pump inlet fitting. For suction lift applications, install a foot valve on one end of suction tubing and cut the tubing to a length such that the foot valve hangs vertically about 1 in (25mm) above the bottom of the tank. Avoid any loops in the tubing run that could form a vapor trap. Running the tubing through a length of rigid pipe will help to keep tubing straight (see Figure 4). Total vertical suction lift should be no more than 5ft. (1.5m).

Attach tubing as shown in Figure 5. First slide the coupling nut, small end first, onto the tubing. Then slide on the clamp ring. Next push the tubing onto the tubing adapter fitting. (Tips: Place adapter fitting on a flat surface such as a table top and press tubing down on top of it *all the way to the lip* of the adapter fitting. If the tubing is stiff from cold, dip the tubing end in hot tap water for a few minutes so it will slide on and flare out more easily. Slide clamp ring down until it tightens over the adapter fitting. Then slide coupling nut down as far as it will go. Insert this arrangement into the suction valve housing. With one hand holding tubing and applying slight downward pressure, tighten the coupling nut until secure.



WARNING: All fittings and coupling nuts should be tightened by hand. If necessary, small pliers may be used to make it snug. DO NOT use excessive force or large wrenches.

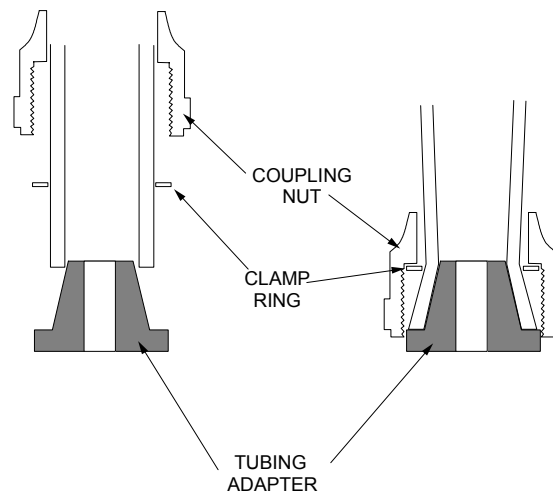

Figure 5 Attach Tubing

2.4 Discharge Tubing

Cut a length of tubing long enough to go from the pump to the application (injection) point. Additional tubing can be ordered from your distributor. Avoid sharp bends or kinks in the tubing and protect the tubing from sharp edges that could chafe or cut it. If applicable, install the injection valve in 1/2" NPT thread at the injection point and connect the discharge tubing to the injection valve.

Attach the tubing as described above, installing it to the discharge valve housing.

2.5 Installing Injection/Back Pressure Valve

A fitting or tee with 1/2" NPTF threads and with sufficient depth will accept the injection valve assembly. If required, trim off an amount of the extension tip until it fits your fitting or tee. (Fig. 6.)

The position of the injection/back pressure valve can be at any orientation as long as the spring is retained in the valve. **DO NOT REMOVE THE SPRING.** Be sure to check and replace the spring as needed. Attach the tubing following the same instructions in section 2.3, connecting the supply tubing.

In addition to preventing backflow from pressurized lines, the injection valve acts as a back pressure valve when pumping into atmosphere or low pressure applications.

IMPORTANT: Always install the injection/back pressure valve at the end of the discharge tubing to prevent over-pumping in atmospheric or low pressure situations.

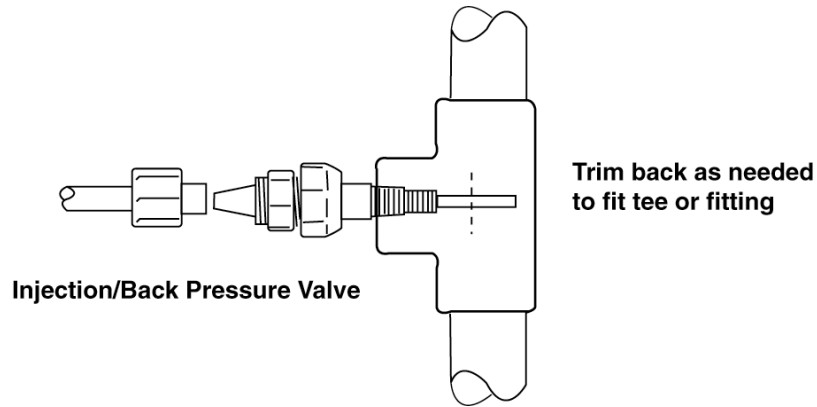

Figure 6 Injection Valve

See Section 5.0 for complete liquid end parts list and exploded view.

2.6 Electrical



WARNING: Risk of electrical shock! This pump is supplied with a grounding conductor and grounding-type attachment plug. To reduce the risk of electrical shock, be certain that it is connected only to a properly grounded, grounding type receptacle.

Connect the pump power cord to a GROUNDED outlet supplying proper voltage. Avoid branch circuits that also supply power to heavy machinery or other equipment that could generate electrical interference.

3.0 OPERATION



3.1 Priming



CAUTION: With enough leverage, the stroke length knob on the EHE pumps can be forced above 100% (by breaking the stop pin). This will damage the pump and will void the warranty.

Install the pump as described above. With the pump plugged in but not pumping, set stroke length at 100% and frequency at 360 (use the ▲ or ▼ buttons as necessary to adjust the frequency). Disconnect the discharge tubing from the injection valve. Push the **START/STOP** button to start the pump. *As soon as* liquid enters the discharge tubing at the pump head, push the **START/STOP** button again to stop the pump. Reconnect the discharge tubing to the injection valve.

If the pump does not self prime, remove the check valve housing on the discharge and suction sides to make sure the valve cartridges and gaskets are in correct positions (see Section 4.2). Remove and shake cartridges to make sure ball is loose inside. Wetting cartridges before re-installing will help in priming.

3.2 Adjustment

The pump will operate best with the stroke length at 100%. If less than full output is required, set the frequency to the desired percentage of maximum.

Example: Model EHE30E1-VC has maximum output of 5.5 GPH.

Desired output is 4.0 GPH.

$4.0 \div 5.5 = 0.73$ or 73%. 73% of 360 is 263.

Press the ▲ or ▼ buttons as necessary to set the frequency to 263.

If very low outputs are required, it will be necessary to also reduce the stroke length.

(Minimum recommended stroke length is 20%.)

3.3 Calibration

If exact output calibration is required, first prime and adjust the pump as above. Then connect a calibration column to the suction side of the pump. Turn the pump on for one minute and read the amount of liquid pumped from the column. Adjust the frequency up or down as necessary and check the output again. When the desired output is reached, disconnect the calibration column and reconnect the suction tubing. (See Figure 7.)

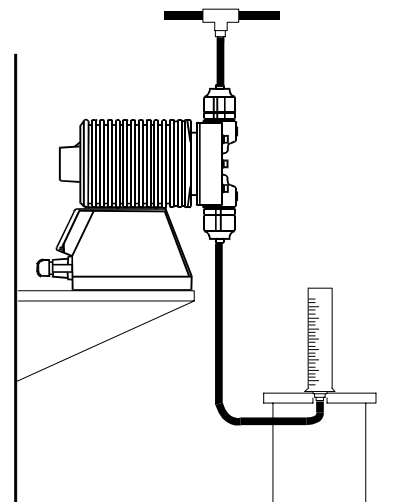

Figure 7 Calibration

3.4 External Control

The EHE Series is able to operate in both digital and analog external modes. An external stop function is also available.

Display/Keypad Overview

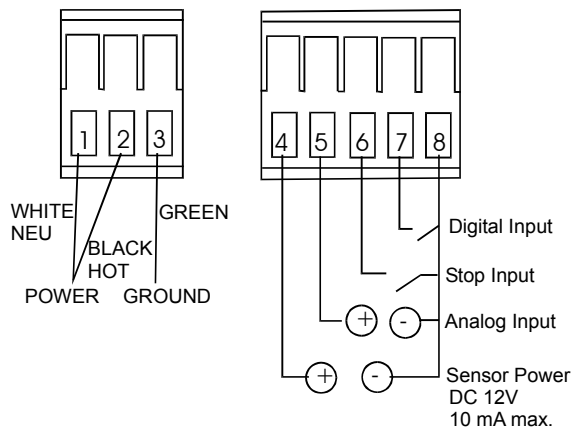
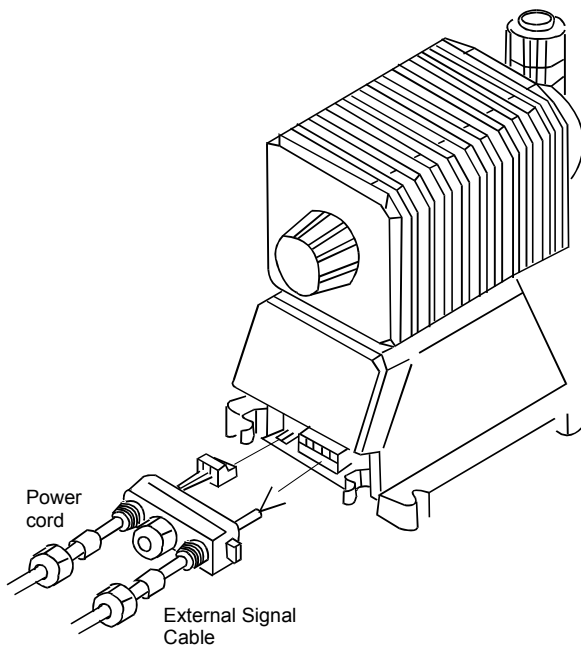
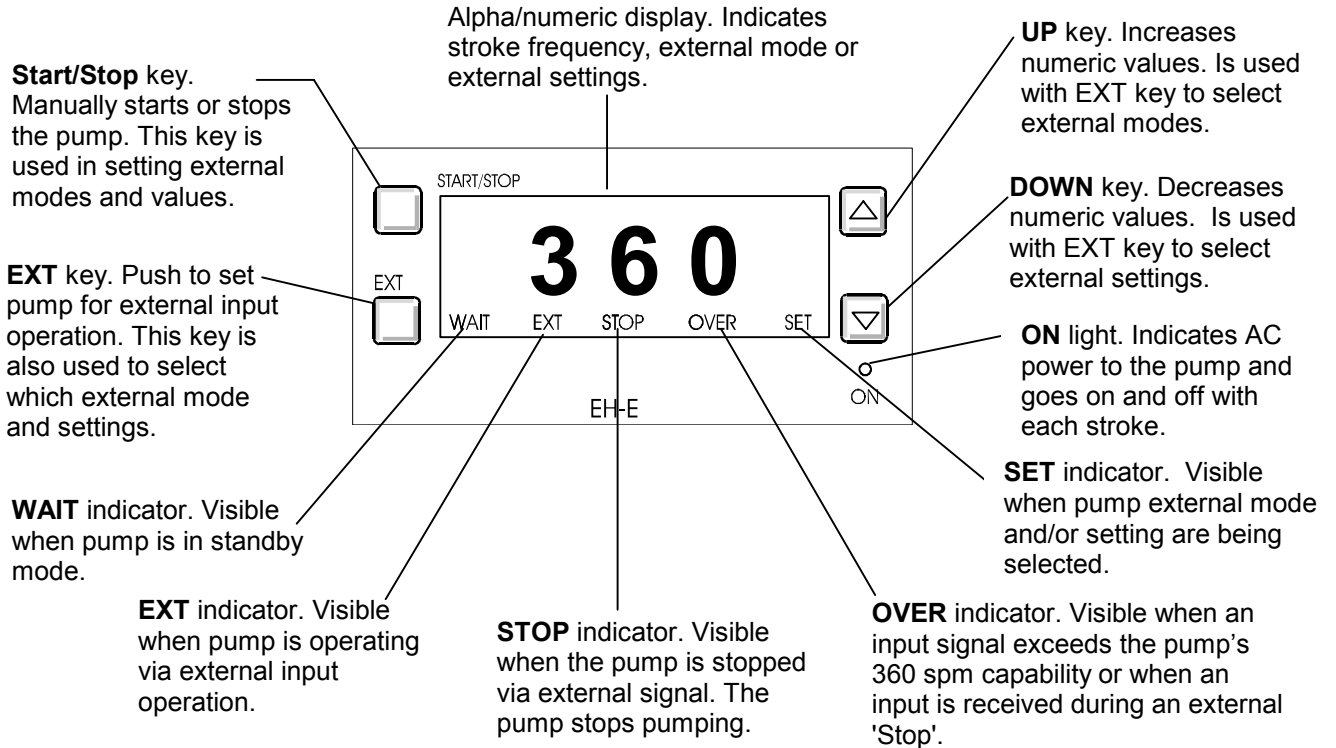
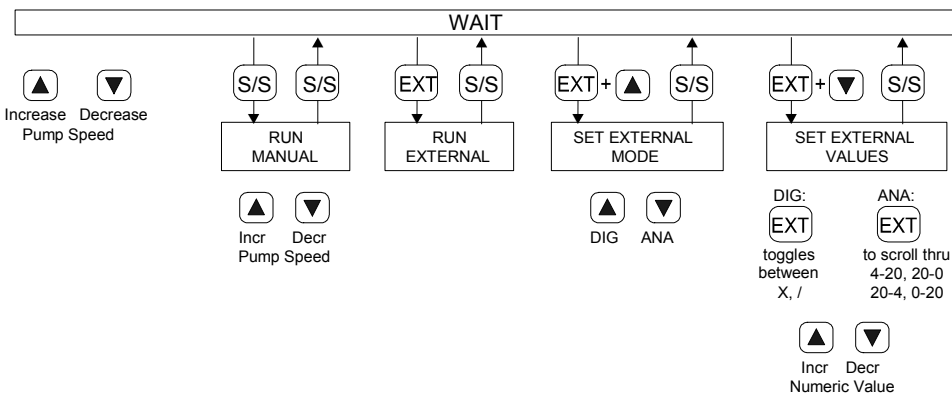

Figure 8

EH-E Quick Reference Guide

FROM:	PRESS:	TO:
WAIT MODE	S/S	Run in manual mode
	▼	Decrease frequency (1 to 360 SPM)
	▲	Increase frequency (1 to 360 SPM)
	EXT	Run in EXT ternal mode
	EXT + ▲	SET external mode
	EXT + ▼	SET external values
RUNNING IN MANUAL MODE	▲	Decrease frequency (1 to 360 SPM)
	▼	Increase frequency (1 to 360 SPM)
	S/S	Return to WAIT and stop pump operation
RUNNING IN EXT MODE	S/S	Return to WAIT and stop pump operation
SET EXTERNAL MODE	▲ OR ▼	Toggles between DIG (multiply or divide) and ANA (milliamp input)
	S/S	Accept data and return to WAIT mode
SET EXTERNAL VALUES	DIG	
	EXT	Select '/' (divide) or 'X' (multiply)
	▲	Increase value (1 to 999)
	▼	Decrease value (1 to 999)
	S/S	Accept data and return to WAIT mode
	ANA	
	EXT	Scroll through the following selections: Analog signal level (point 1) Pump speed (point 1) Analog signal level (point 2) Pump speed (point 2)
	▲	Increase value (A from 0.00 to 20.0mA) (P from 0 to 360 SPM)
	▼	Decrease value (A and P)
	S/S	Accept data and return to WAIT mode



Digital Mode

In digital mode, the pump accepts a pulse signal from a flowmeter or other instrument. The pump can be set to divide pulses by a factor of 1 to 999; or in multiply mode, 1 input pulse can produce 1 to 999 pump strokes. The minimum pulse width for input pulses is 10msec.

Connecting a digital input device

Disconnect AC power to the pump. Remove the four screws from the terminal block cover and remove the cover. Remove the cord nut and bushing from the terminal block cover. Remove the terminal block from the connector. Slide the nut and bushing over the external control cable and insert the cable through the terminal block cover. Strip 1/4" insulation from conductors and connect the positive side to terminal 7 and the negative side to terminal 8. (See Figure 8 and the schematic, below.)

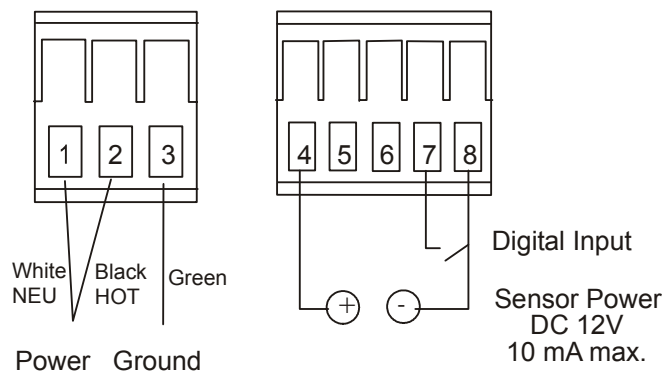

Connecting a digital input to multiple pumps in parallel

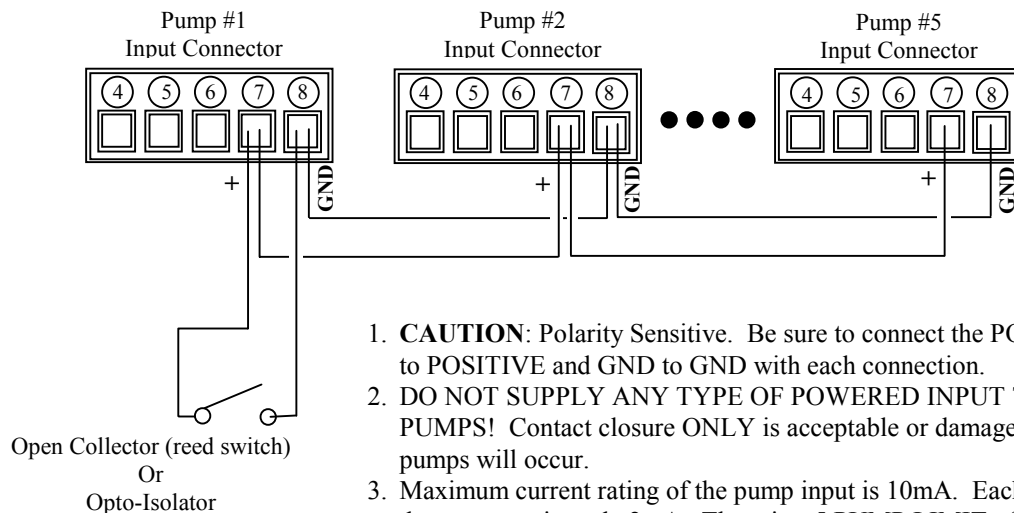

1. **CAUTION:** Polarity Sensitive. Be sure to connect the POSITIVE to POSITIVE and GND to GND with each connection.
2. **DO NOT SUPPLY ANY TYPE OF POWERED INPUT TO THE PUMPS!** Contact closure ONLY is acceptable or damage to the pumps will occur.
3. Maximum current rating of the pump input is 10mA. Each pump draws approximately 2mA. There is a 5 PUMP LIMIT of pumps in parallel.
4. Make sure the switching device can handle the maximum current in the system.

$$\text{Current} = 2\text{mA} \times \# \text{ of Pumps}$$

Sensor Power

The control circuit of the EHE series has the ability to provide 12 VDC at up to 10 mA to power a Hall effect sensor or similar device.

Connect the sensor power leads to terminal 4 (positive) and terminal 8 (negative) of the terminal block.

Settings

Start with pump in the **WAIT** state. If it is not currently in wait, press **START/STOP** once.

Press **▲** and **EXT** simultaneously.

The **SET** indicator is highlighted and DIG (digital) or ANA (analog) will be displayed.

1. Set it to digital mode

If DIG is displayed, press **START/STOP** to accept that mode.

You will be returned to the **WAIT** state.

If ANA is displayed, press the **▲** button to change to **DIG** and then press **START/STOP** to enter that choice.

You will be returned to the **WAIT** state.

2. Set multiply or divide

To set values for digital operation, press **EXT** and **▼** simultaneously. The display will show / or X and a 3 digit number. Now pressing the **EXT** button will alternate between X (multiply) and / (divide).

3. Set the value

▲ or **▼** will increase or decrease the multiplier or divider. Pressing a button once will change the value by one. Holding a button down will continuously increment or decrement the value, slowly at first, then rapidly. Press **START/STOP** to accept values and return to **WAIT**.

Press **EXT** to operate the pump in external mode. The pump will now respond to the incoming pulse signal. The stroke length can be adjusted manually to set the volume pumped per stroke.

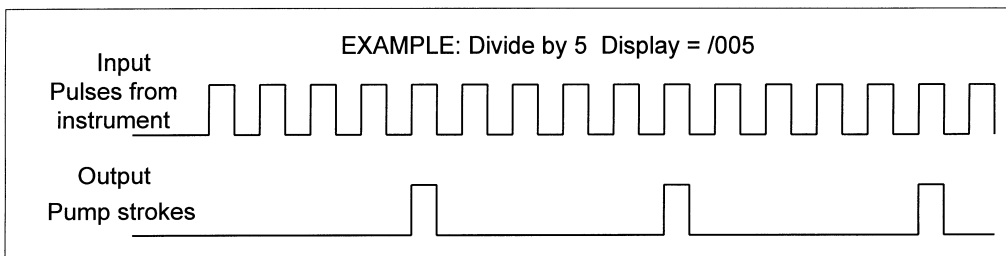
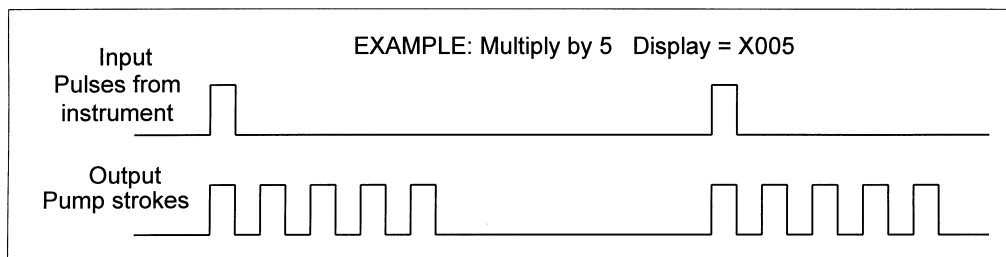

Analog Mode



CAUTION: Open loop signal voltage must not exceed 25 VDC. If the signal voltage is greater than 25 VDC, power down the signal source prior to connection.

In analog mode the pump will accept a milliamp signal and produce a pump speed proportional to the signal level received. The input resistance of the analog signal is 250Ω. The pump's response can be fine tuned by variable set points to meet system requirements.

Connecting an analog signal device

Disconnect AC power to the pump. Remove the four screws from the terminal block cover and remove the cover. Remove the cord nut and bushing from the terminal block cover. Remove the terminal block from the connector. Slide the nut and bushing over the external control cable and insert the cable through the terminal block cover. Strip 1/4" insulation from conductors and connect the positive side to terminal 5 and the negative side to terminal 8. (See Figure 8 and the schematic below.)

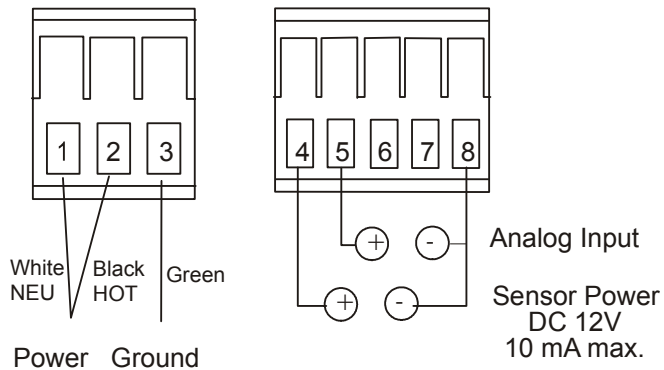

Output Power

The control circuit of the EHE control module has the ability to provide 12 VDC to power a loop powered device. Wiring is as follows:

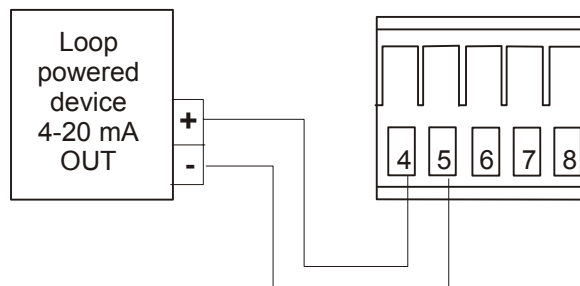

Settings

The pump's response to a 4 to 20 milliampere signal can be adjusted to meet almost any need. The adjustment is done by selecting two points. A signal level and a pump speed are entered for each point. These two points determine a straight line and the pump speed resulting from any given signal will be defined by that line. The factory settings for point 1 are 4.0 mA, 0 spm and for point 2 are 20.0 mA, 360 spm. An 'A' in the leftmost position of the display indicates the data shown is Analog signal level. A 'P' indicates Pump speed. The 1 on the right side of the display is highlighted when viewing or changing data for point 1. The 2 is highlighted to indicate data for point 2.

Start with pump in the **WAIT** state. If it is not currently in wait, press **START/STOP** once.

1. Set analog mode.

Press **▲** and **EXT** simultaneously.

The **SET** indicator is highlighted and DIG (digital) or ANA (analog) will be displayed.

If ANA is displayed, press **START/STOP** to accept that mode.

You will be returned to the **WAIT** state.

If DIG is displayed, press **▼** to change to ANA and then press **START/STOP** to enter that choice. You will be returned to the **WAIT** state.

2. Set values

To set values for analog operation, press **EXT** and **▼** simultaneously. The display will show A04.0 (or some value between 00.0 and 20.0 mA) with the point 1 indicator highlighted. Press **▲** or **▼** to adjust the value to the desired analog signal level for point 1.

Press **EXT** to display the pump speed for point 1. The display will show P0 (or some value between 0 and 360 spm) with the point 1 indicator highlighted. Press **▲** or **▼** to adjust the value to the desired pump speed for point 1.

Press **EXT** again to display the analog signal level for point 2, which can be adjusted as for point 1. Pressing **EXT** a third time will display the pump speed for point 2m which can be adjusted as for point 1.

Continued pressing of **EXT** key will scroll through the above four parameters for review or adjustment. When settings are as desired, press **START/STOP** to accept the new values and return to **WAIT**.

Press **EXT** to operate the pump in external mode. The pump speed will now be determined by the level of the milliamp signal as shown in the graph. The stroke length can be adjusted manually to set the volume pumped per stroke.

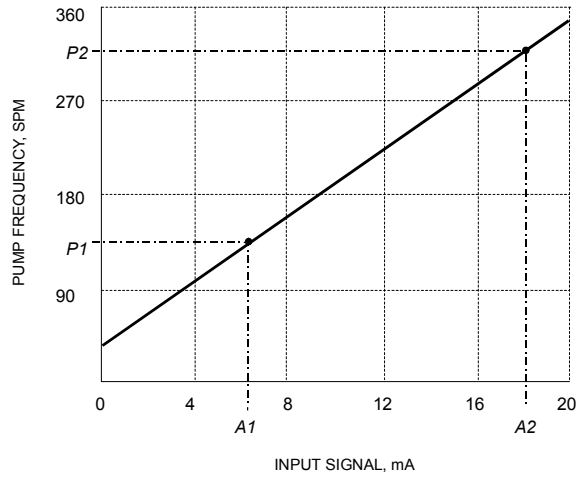

3.5 STOP Function

The EHE series pump also includes a **STOP** function which allows an external signal to stop the operation of the pump.

A switch or solid state device capable of switching 5 VDC at 2 mA can be connected to terminals 6 (positive) and 8 (negative) of the terminal block. Closing this circuit temporarily interrupts pump operation. Opening this circuit resumes pump operation. If the pump is operating in external digital mode, any pulses received while the pump is stopped will be saved (up to a maximum of 255). When pump operation resumes, saved pulses will allow the pump to “catch up” by producing the correct number of pump strokes that should have occurred while it was stopped. The 'Over' indicator will light up if the pump receives pulses while in the 'Stopped' condition (see Figure 8 and the schematic below).

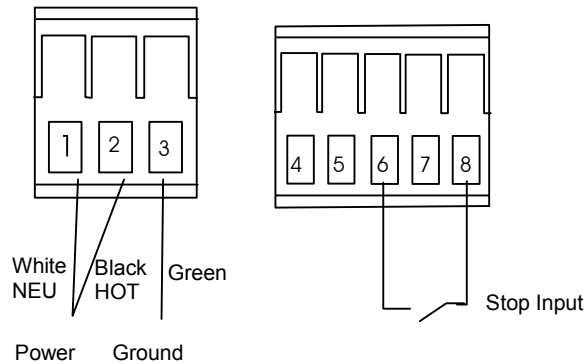

3.6 AC Power Interruption

If AC power is interrupted, the pump will power up as shown below:

State preceding power OFF	State following power ON
WAIT	WAIT
Run Manual	Run manual
Run external	Run external
Set EXTERNAL mode	WAIT
Set EXTERNAL values	WAIT

4.0 MAINTENANCE



CAUTION: Before working on the pump, disconnect the power cord, depressurize the discharge tubing and drain or flush any residual liquid from the pump head and valves. Always wear protective gear when working around chemicals.

4.1 Diaphragm Replacement

Disconnect AC power to the pump and disconnect the suction tubing and discharge tubing. Remove the four head bolts with a 4mm hex wrench. Turn the stroke length knob fully counter-clockwise. Unscrew the diaphragm and remove its retainer (small disk behind the diaphragm). **CAUTION:** *There may be small brass spacers between the retainer and the armature shaft. These spacers need to be re-used when replacing the diaphragm.* Install the new retainer and diaphragm on the shaft. Turn the diaphragm clockwise until it bottoms on the shaft. Replace the pump head and tighten the head bolts to a torque of 19 lb-in (2.16 N-m).

4.2 Valve Replacement

Making sure the discharge side has been depressurized, remove the suction and discharge tubing. Remove the suction fitting, two valve cartridges*, o-ring and gasket(s). Install the new o-ring, gasket(s) and valve cartridges. Be sure both valve seats are in the same orientation. Refer to Figure 9 below. Tighten the suction fitting. Similarly remove and replace the discharge valve cartridges, o-ring and gasket(s).

*EHE45 and EHE55 series have one valve cartridge on the suction and discharge sides. Refer to Section 5.0 for exploded view drawing and parts list.

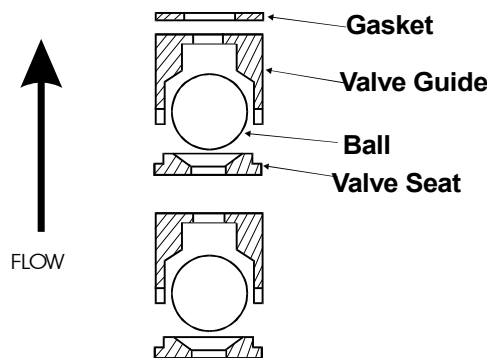

Figure 9 Valve Cartridge Orientation

4.3 Tubing

Check ends of tubing for splits, cracks or thin spots. Examine the full length of tubing for damage due to chafing, abrasion, stress cracks, excessive temperature or exposure to ultraviolet light (direct sunlight or mercury vapor lamps). If any signs of deterioration exist, replace the entire length of tubing. It is a good idea to replace discharge tubing on a regular preventative maintenance schedule every 12 months.

5.0 EXPLODED VIEW AND PARTS GUIDE

5.1 How to order parts for your metering pump.

Have your catalog or model number ready. This is found on the silver label on the side of the pump.

From the exploded view drawing, identify the item number of the part(s) to be ordered.

The item numbers are listed and include part number, description and size/material information.

Contact your Walchem distributor for further assistance.

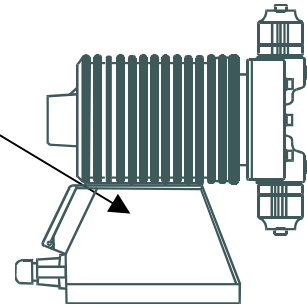

5.2 Accessories (Not shown)

Part No.	Description	Size	Liquid End Mtl
E90005	Valve, Injection 1/2	30, 35, 45	VC
E90006	Valve, Injection 1/2	30, 35, 45	V6, VE, VF
E90007	Valve, Injection, 1/2	55	VC, VM
E90008	Valve, Injection, 1/2	55	V6, VE, VF
E90009	Valve, Injection, 1/2	30, 35, 45	PC
E90010	Valve, Injection, 1/2	30, 35, 45	PE
E90011	Valve, Injection, 1/2	55	PC
E90012	Valve, Injection, 1/2	55	PE
E90022	Valve, Injection/Back Pressure, 1/2	30, 35, 45, 55	FC(w/FKM)
E90068	Valve, Back Pressure/Anti-Syphon, 1/2	30, 35, 45, 55	VC, VE, V6, VM, VF
E90069	Valve, Back Pressure/Anti-Syphon, 1/2	30, 35, 45, 55	PC, PE
E90016	Valve, Foot, 1/2	30, 35, 45, 55	VC, VM
E90017	Valve, Foot, 1/2	30, 35, 45, 55	V6
E90018	Valve, Foot, 1/2	30, 35, 45, 55	PC
E90036	Valve, Foot, 1/2	30, 35, 45, 55	PE
E90037	Valve, Foot, 1/2	30, 35, 45, 55	VE
E90193	Valve, Foot, 1/2	30, 35, 45, 55	VF
E90275	Valve, Foot, 1/2	30, 35, 45, 55	FC
E00001-00	Tubing, 1/2 OD LLDPE per foot	30,35,45,55	all
E00001	Tubing, 1/2 OD LLDPE, 20 FT	30,35,45,55	all
E00001-50	Tubing, 1/2 OD LLDPE, 50 FT	30,35,45,55	all
E00001-100	Tubing, 1/2 OD LLDPE, 100 FT	30,35,45,55	all
E00001-250	Tubing, 1/2 OD LLDPE, 250 FT	30,35,45,55	all
E00001-500	Tubing, 1/2 OD LLDPE, 500 FT	30,35,45,55	all
E00071	Weight, Ceramic	30,35,45,55	all
*E00030	Fitting (NPT Valve Housing) 1/2" NPT, PVC	30,35	VC, VE, V6, VF
*E00031	Fitting (NPT Valve Housing) 1/2" NPT, PP	30,35	PC, PE
*E00032	Fitting (NPT Valve Housing) 1/2" NPT, PVDF	30,35	FC
*E00033	Fitting (NPT Valve Housing) 3/4" NPT, PVC	30,35	VC, VE, V6, VF
*E00034	Fitting (NPT Valve Housing) 3/4" NPT, PP	30,35	PC, PE
*E00035	Fitting (NPT Valve Housing) 3/4" NPT, PVDF	30,35	FC
*E00036	Fitting (NPT Valve Housing) 3/4" NPT, PVC	45	VC, VE, V6, VF
*E00037	Fitting (NPT Valve Housing) 3/4" NPT, PP	45	PC, PE
*E00038	Fitting (NPT Valve Housing) 3/4" NPT, PVDF	45	FC
*E00039	Fitting (NPT Valve Housing) 3/4" NPT, PVC	55	VC, VE, V6, VM, VF
*E00040	Fitting (NPT Valve Housing) 3/4" NPT, PP	55	PC, PE
*E00041	Fitting (NPT Valve Housing) 3/4" NPT, PVDF	55	FC

* Fittings replace item 3 (Valve Housing) shown in exploded view.

5.4 EHE 55 Liquid End Exploded View

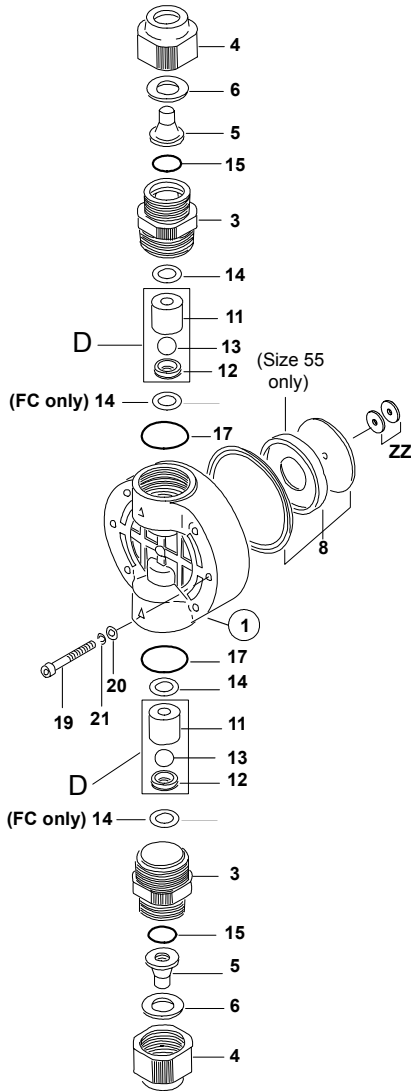

Item	Part No	Description	Qty	Size	Liquid End Mtl	
1	EH0654	Head, E55 PVC	1	55	V6, VC, VE, VF	
	EH0684	Head, E55 GFRPP	1	55	PC, PE	
	EH0690	Head, E55 PVC Machined	1	55	VM	
	EH0915	Head, E55 PVDF	1	55	FC	
3	EH0656	Housing, Valve, E55, PVC	2	55	V6, VC, VE, VM, VF	
	EH0685	Housing, Valve, E55, GFRPP	2	55	PC, PE	
	EH0916	Housing, Valve, 1/2 PVDF	2	55	FC	
4	EH0657	Nut, Coupling, E55, PVC	2	55	V6, VC, VE, VM, VF	
	EH0686	Nut, Coupling, E55, GFRPP	2	55	PC, PE	
	EH0917	Nut, Coupling, E55, PVDF	2	55	FC	
5	EH0730	Adapter, E55, 1/2, PVC	2	55	V6, VC, VE, VM, VF	
	EH0735	Adapter, E55, 1/2, GFRPP	2	55	PC, PE	
	EH0923	Adapter, E55, PVDF	2	55	FC	
6	EH0731	Clamp Ring, E55, 1/2, SS	2	55	All	
*	8	E90087	Diaphragm and Retainer	1	55	All
*	11	EH0661	Guide, Valve, .625, PVC	2	55	V6, VC, VE, VM, VF
	EH0718	Guide, Valve, .625, GFRPP	2	55	PC, PE	
	EH0918	Guide, Valve, 0.625, PVDF	2	55	FC	
*	12	EH0662	Seat, Valve, .625, FKM	2	55	VC, VM, PC
	EH0663	Seat, Valve, .625, EPDM	2	55	V6, VE, PE, VF	
	EH0920	Seat, Valve, 0.625, PCTFE	2	55	FC	
*	13	EH0664	Ball, Valve, .625, CE	2	55	VC, VE, VM, PC, PE, FC
	EH0665	Ball, Valve, .625, SS	2	55	V6	
	E00073	Ball, Valve, .625, PTFE	2	55	VF	
*	14	EH0666	Gasket, Valve, .625, PTFE	2	55	V6, VC, VE, VM, PC, PE, VF
	EH0921	Gasket, Valve, 0.625 PTFE	4	55	FC	
*	15	EH0122	O-Ring, P16 FKM	2	55	VC, VM, PC
	EH0127	O-Ring, P16 EPDM	2	55	V6, VE, PE, VF	
	EH0924	Gasket, Adapter, PTFE	2	55	FC	
*	17	EH0667	O-Ring, 29.8 X 2.62, FKM	2	55	VC, VM, PC
	EH0668	O-Ring, 29.8 X 2.62, EPDM	2	55	V6, VE, PE, VF	
	EH0925	Gasket, Housing, PTFE	2	55	FC	
19	EH0669	Bolt, M5 X 50 SHC SS	6	55	V6, VC, VE, PC, PE, VF	
	EH0691	Bolt, M5 X 70 SHC, SS	6	55	VM	
20	EH0161	Washer, M5 Flat	6	55	all	
21	EH0160	Washer, M5 Lock	6	55	all	
ZZ	-----	Brass Spacers			Drive specific/ re-use when replacing diaphragm	

* Included in spare parts kit

C Head Assembly EHE 55

C Head Assembly
D Valve Cartridge

See page 21 for these
assembly part numbers

5.5 Drive Control Components

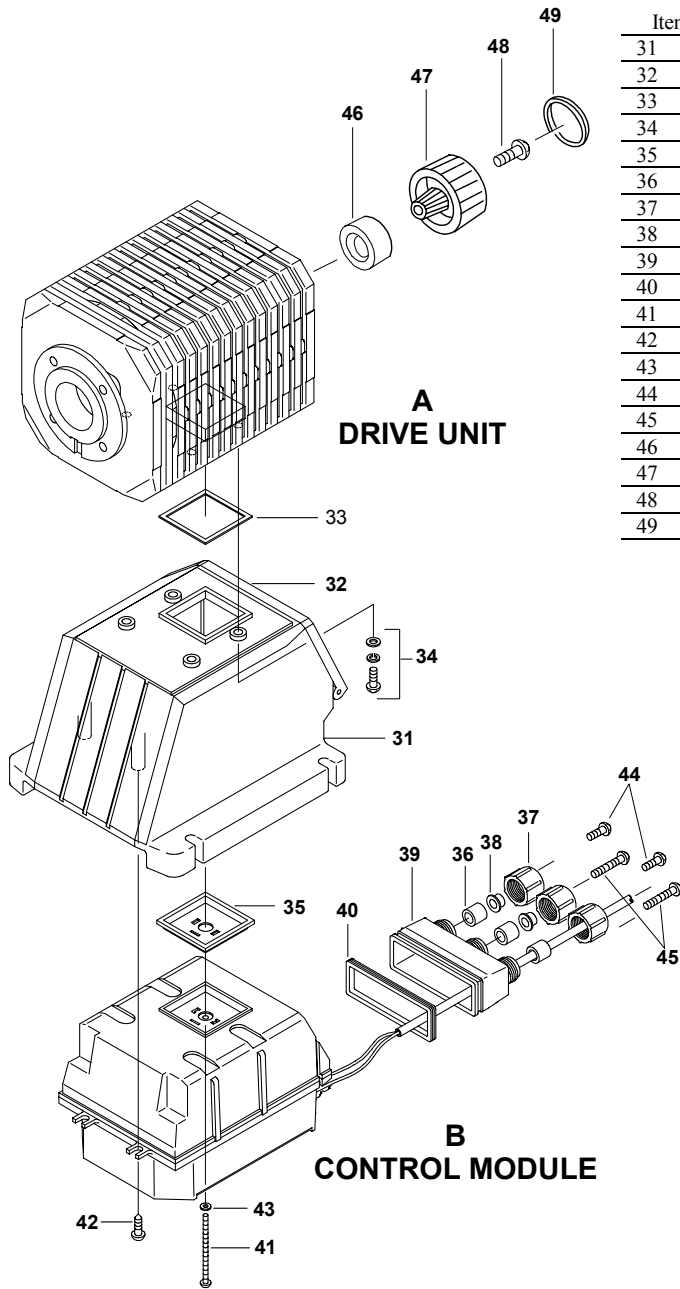

Item	Part No.	Description	Qty
31	EH0700	Base, Pump, EHE	1
32	EH0697	Cover, Control Panel	1
33	EH0698	Gasket, EHE Pump Base	1
34	EH1071	Screw, M5 x 12, SS, PH	4
35	EH0696	Gasket, Terminal Block	1
36	EH0202	Grommet, Cord	3
37	EH0205	Nut, Strain Relief	3
38	EH0204	Cap, Strain Relief	2
39	EH0706	Box, Terminal, EHE	1
40	EH1036	Gasket, Terminal Box	1
41	EH0710	Screw, M3 x 50, SS, PH	1
42	EH0711	Screw, 5-10 SS PH Self Tap	2
43	EH0261	Gasket, M3 x 5 Bolt	1
44	EH1037	Screw, M3.5 x 10, SS, PH	2
45	EH1038	Screw, M3.5 x 25, SS, PH	2
46	EH0892	Gasket, Stroke Adjustment	1
47	EH0871	Knob, Stroke length Adj.	1
48	EH0873	Screw, M4 x 30 SS PH	1
49	EH0141	Cap, Stroke Length Adj Knob	1

5.6 Assembly Part Numbers

Key letter from exploded view drawing, previous pages

- A Drive Unit
- B Control Module
- C Head Assembly
- D Valve Cartridge

EHE
35
E
1
-
VC

Series Size Control Voltage Liquid End

Pump Model	A	B	C								
	Drive Unit Use P/N:	Control Module Use P/N:	Head Assembly Liquid End Code								
			VC	VE	VF	V6	PC	PE	VM	FC	
EHE30E1-	HE30-1	EHC-E11UPE (115 V)	E30VC	E30VE	E30VF	E30V6	E30PC	E30PE	-	E30FC	
EHE30E2-	HE30-2	EHC-E23UPE (230 V)									
EHE35E1-	HE35-1	EHC-E11UPE (115 V)	E35VC	E35VE	E35VF	E35V6	E35PC	E35PE	-	E35FC	
EHE35E2-	HE35-2	EHC-E23UPE (230 V)									
EHE45E1-	HE45-1	EHC-E11UPE (115 V)	E45VC	E45VE	E45VF	E45V6	E45PC	E45PE	-	E45FC	
EHE45E2-	HE45-2	EHC-E23UPE (230 V)									
EHE55E1-	HE55-1	EHC-E11UPE (115 V)	E55VC	E55VE	E55VF	E55V6	E55PC	E55PE	E55VM	E55FC	
EHE55E2-	HE55-2	EHC-E23UPE (230 V)									
D Valve Cartridge EHE pump size			30, 35	E90052	E90071	E90313	E90072	E90055	E90073	-	E90316
			45	E90074	E90075	E90314	E90076	E90077	E90078	-	E90317
			55	E90079	E90080	E90315	E90081	E90082	E90083	E90079	E90318

5.7 Spare Parts Kit

The spare parts kit number is the Head Assembly part number with ‘-PK’ at the end. (E30VC-PK, E30VE-PK, E30V6-PK, etc.)

Spare parts kit includes diaphragm and retainer,
 valve guides
 valve seats
 valve balls
 valve gaskets
 o-rings

6.0 TROUBLESHOOTING



Caution: Before working on the pump disconnect the power cord, depressurize the discharge tubing and drain or flush any residual liquid from the pump head and valves.

<u>Problem</u>	<u>Possible Cause</u>	<u>Corrective Action</u>
<i>Pump does not start</i>	Faulty wiring	Correct wiring
	Improper voltage	Connect to proper voltage source
	Electronic control unit is damaged	Replace control unit
<i>Pump does not prime</i>	Pump stroke length is too short	Operate pump with stroke length set at 100% until primed. Then set the stroke length as needed to obtain desired output.
	Air in suction tubing	Reroute suction tubing to eliminate air trap
	Valve gasket is missing	Install valve gasket
	Valve set assembly direction is wrong.	Reassemble valve set
	Pump is air locked	Prime pump per instructions

<u>Problem</u>	<u>Possible Cause</u>	<u>Corrective Action</u>
<i>Output fluctuates</i>	Suction or discharge valve is clogged with foreign matter	Disassemble, inspect, clean
	Air is trapped in pump	Prime pump per instructions
	Overfeeding	Install injection valve or back pressure valve Check stroke length knob (@ 0%, pump should not pump)
	Diaphragm is damaged	Replace diaphragm
	Worn check valves	Replace valve cartridges
<i>Liquid leaks</i>	Fitting or coupling nut is loose	Tighten
	Pump head is loose	Tighten pump head bolts Torque: 19 lb-in (2.16 N-m)
	Diaphragm is damaged	Replace diaphragm
	O-ring or valve gasket	Install o-ring or valve gasket missing

7.0 SERVICE POLICY

The EHE Series electronic metering pumps have a 2-year warranty. Contact your Walchem distributor for service.

W A L C H E M

Five Boynton Road Hopping Brook Park Holliston, MA 01746 USA TEL 508-429-1110 FAX 508-429-7433

Website: www.walchem.com