

# Installation Guidelines

## General Installation

1. Read and follow all instructions and safety warnings in the Wanner Installation/ Operation Manual.
2. Do not exceed the manufacturer's recommended maximum RPM or pressure.
3. Follow all codes and regulations regarding installation and operation of the pumping system.
4. For safety and easier servicing, provide adequate work space around the pump. Allow room for checking the oil level, changing the oil, and removing the valve plate and manifold.
5. To prevent vibration, mount the pump and motor securely to a rigid, level base.
6. Be sure the inlet system provides NPSH that exceeds the sum of NPSHr of the pump, all friction losses and acceleration head.
7. Do not exceed the manufacturer's recommended maximum inlet pressure. Install an inlet pressure regulator if necessary.
8. On a belt-drive system, align the belts and pulleys accurately, and follow the manufacturer's specifications for belt tension. On a direct-drive system, align shafts properly.
9. Install adequate safety guards on all belts and couplings.
10. Install drains in all low points of the system to allow draining in freezing conditions.

## Supply Tank Guidelines

1. Use a supply tank that is large enough to provide time for any entrained air in the fluid to escape.
2. Do not attach the supply tank to the pump and motor stand.
3. Install a separate inlet line from the supply tank to each pump.
4. Install the inlet and bypass lines so they empty into the supply tank below the lowest water level, on the opposite side of the baffle from the pump outlet line.
5. If a line strainer is used in the system, install it in the inlet line to the supply tank.
6. Install a completely-submerged baffle plate in the supply tank to separate the incoming and outgoing liquid so as to reduce aeration and turbulence.
7. Install a vortex breaker in the supply tank over the outlet port to the pump.
8. Place a cover of the supply tank to prevent foreign objects from falling into it.

## Inlet Piping Guidelines

1. Size the suction line at least one size larger than the pump inlet.
2. Size the suction line so that the velocity will not exceed 1 to 3 ft/sec.  
Velocity =  $0.408 \times \text{gpm} / \text{Pipe ID}^2$
3. Keep the suction line as short and direct as possible.

4. Use flexible hose and/or expansion joints to absorb vibrations, expansions and contractions.
5. If possible, keep suction line level. Have no high points to collect vapor unless these high points are vented.
6. For Suction-Feed Systems, when pumping at temperatures above 160° F (71° C) use a pressure-feed system.

Install draincocks at any low points of the suction line to permit draining in freezing conditions.

Provide for permanent or temporary installation of a vacuum gauge to monitor the inlet suction. Vacuum at the pump inlet should not exceed 7 inches of Hg at 70° F (180 mm Hg at 70 liters/min and 21° C). With Teflon® diaphragms, the inlet must be flooded.

Do not supply more than one pump from the same inlet line.

7. To reduce turbulence and resistance, do not use 90° elbows. If turns are necessary in the suction line, use 45° elbows or arrange sweeping curves in the inlet hose.
8. If a block valve is used, be sure it is full-opening so that the flow to the pump is not restricted. The opening should be at least the same diameter as the inlet plumbing I.D.
9. Do not use a line strainer or filter in the suction line unless regular maintenance is assured. If used, it should have a free-flow area at least three times the free-flow area of the inlet.
10. Install piping supports where necessary to relieve strain on the inlet line and to minimize vibration.

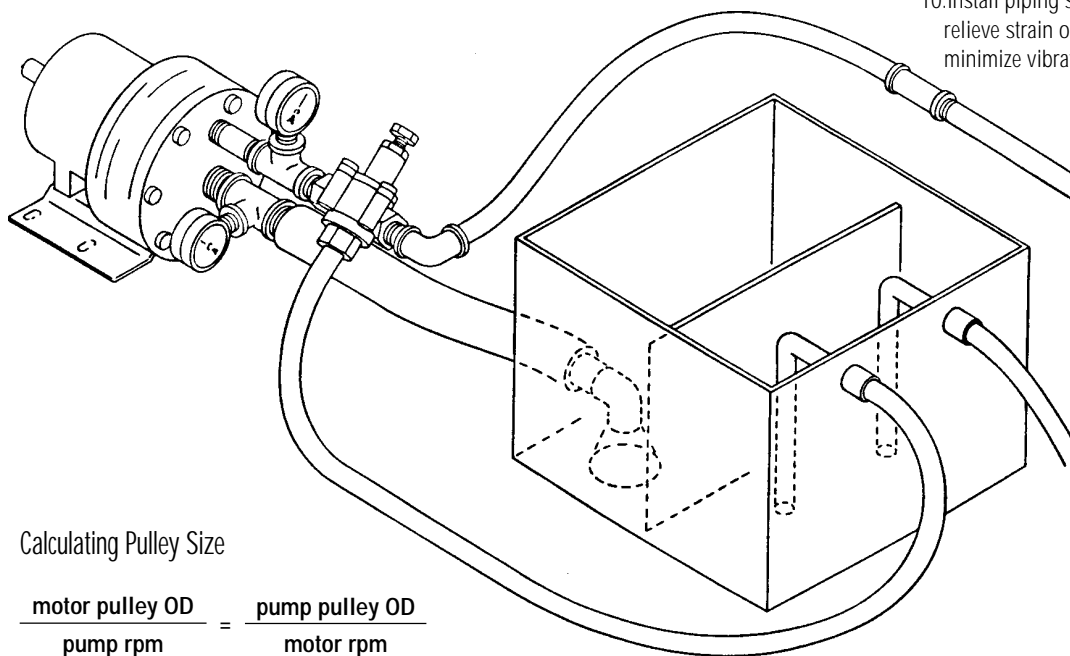

## Calculating Pulley Size

$$\frac{\text{motor pulley OD}}{\text{pump rpm}} = \frac{\text{pump pulley OD}}{\text{motor rpm}}$$

# Installation Guidelines

## Discharge Line Guidelines

1. Size the discharge line one or two sizes larger than the pump discharge opening.
2. Size the discharge line so that the velocity will not exceed 8 to 10 ft/sec.
3. Use flexible hose between the pump and hard piping to absorb vibrations, expansions or contractions.
4. Install a pressure gauge between the pump and the pressure regulator, and as close as possible to the pump outlet.
5. Install a pressure regulator, unloader valve, or another safety relief valve in the discharge line.
6. Never install a shut-off valve in the discharge line between the pump and the regulator, or in the bypass line.

## Pressure Regulator Guidelines

1. Size the discharge so that when fully open, it will be large enough to relieve the full capacity of the pump without excessive overpressurizing of the system.
2. Locate the valve as close to the pump as possible and ahead of any other valves.
3. Adjust the pressure regulating valve to no more than 10% over the maximum working pressure of the system. Do not exceed the manufacturer's pressure rating or the pump and/or regulator.

## Frequently Asked Questions about Hydra-Cell Pumps

### 1) What type of oil should be used with Hydra-Cell® pumps?

The pump lubricant in Hydra-Cell pumps performs two separate functions. First, it provides flooded oil lubrication to the four tapered roller bearings. Secondly, it provides the hydraulically balanced displacement to the diaphragms. Critical to the hydraulic system within each piston, the oil must flow smoothly under high pressures.

The family of Hydra-Oil products provides a wide variety of standard duty motor oils, synthetic, and food grade lubricants to meet these demanding requirements.

### 2) Which way do I rotate the shaft when setting up the drive for my Hydra-Cell® pump?

The smooth, positive displacement delivery of the Hydra-Cell pump can be achieved when rotating the shaft in either direction.

### 3) What happens if the Hydra-Cell® pump runs dry?

The unique, sealless, pumping action of the Hydra-Cell pump does not require lubrication from the process fluid. In the event of your tank running dry, and air being pulled through the pump, no damage will occur. As fluid again is available to the tank, the pump will resume pumping.

### 4) What is the maximum particle size that can pass through the Hydra-Cell® pump?

Round particles up to 500 microns can pass through the D-10 and D-12 pumps. The H-25 and D-35 pumps can handle up to 800 microns. To maximize the check valve opening, pumps must be run at over 50% of

rated RPM. Critical to successfully pumping particulate is that all particles are fully suspended in the fluid to avoid any settling out of the solids. With intermittent duty, care must be taken to avoid excessive settling in the inlet and discharge plumbing.

### 5) Are the Hydra-Cell® pumps easy to fix?

Hydra-Cell pumps are engineered to be easy and inexpensive to service. With regular oil changes, most wear is restricted to the check valve components in the fluid end pump head. All wear items are available in repair kits that include service and parts manuals to allow for fast and easy repairs in the field.

### 6) How long can I expect the diaphragms to last?

The life span of our elastomeric (other than Teflon) diaphragms is indefinite. When installed properly, and no adverse stresses applied to the diaphragms from excessive vacuum, foreign matter, etc., the hydraulically balanced diaphragm will not be the main wear part.

Due to their more plastic nature, the PTFE Teflon diaphragms will eventually wear. Maximum life is achieved with reduced stroke cams and limiting RPM 's.

### 7) Is a pressure relief valve necessary when using the Hydra-Cell® pump?

Yes. The positive displacement performance of the Hydra-Cell pump requires that each application has a pressure regulating valve in the discharge line to allow fluid to divert in the event that excessive pressure builds in the system. The Hydra-Cell C-valves are the perfect protection for your high pressure system.

### 8) What determines application intermittent duty or continuous duty?

Understanding the duty cycle requirements of a pump is critical to proper pump specification. Using a pump intermittently for 8 to 16 hours a day at room temperature is very different from a 24 hour duty cycle at elevated temperature.

Intermittent, standard duty pump applications will see long life running at all points of the rated performance for a given model.

Those applications running 24 hours/day and/or at elevated temperatures and/or at near maximum pressure may want to gain extra pump life by sizing the application with the next larger pump model.

### 9) How can the right flow be produced for a pump application?

Hydra-Cell pumps use positive displacement performance to produce a steady, dependable flow at pressures from 50 to 2,500 psi. The output of the pump is entirely dependant on the shaft RPM. Once the required flow rate is known, there are many ways to drive the pump. Shaft coupling directly to a motor with a motor adapter is the most popular drive arrangement.

All our pump models utilize different output crankshafts or cams to produce different flow rates at common electric motor speeds (i.e. 1150, 1450, 1750 with 60 Hz power, etc.). In addition, pumps and motors can be mounted side-by-side and pulley driven with V-belts or cog style belts (see calculating pulley size formula below). Other drive configurations include hydraulic motors, air motors, gas engines, PTOs or any other means to drive the shaft.