

Hydra-Cell[®]

Industrial Pumps

Pump/Motor Baseplates & Guards

- Heavy gauge construction
- Powder coated steel or 303 grade stainless steel
- Ready to assemble — all mounting holes fully threaded
- Complete package includes all bolts, guards and shims
- Available for size 56 through 326 NEMA motor frames
- Customized versions available

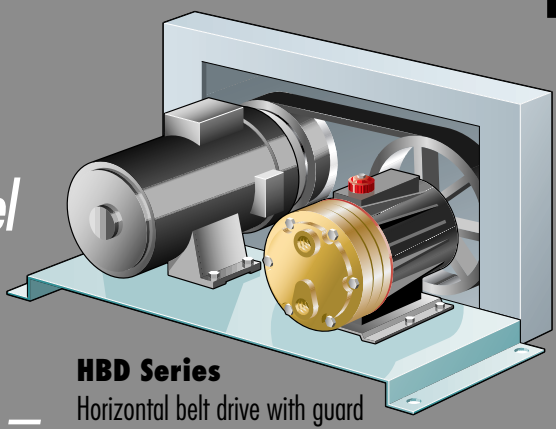

HBD Series
Horizontal belt drive with guard

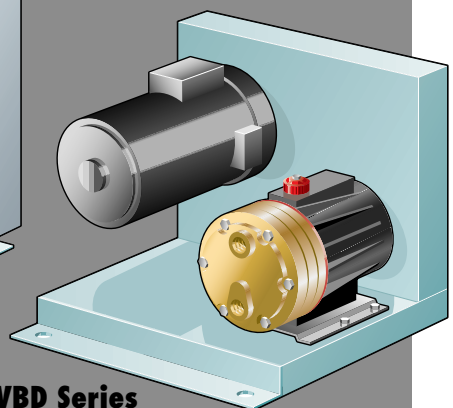

VBD Series
Vertical belt drive with guard

NEW!

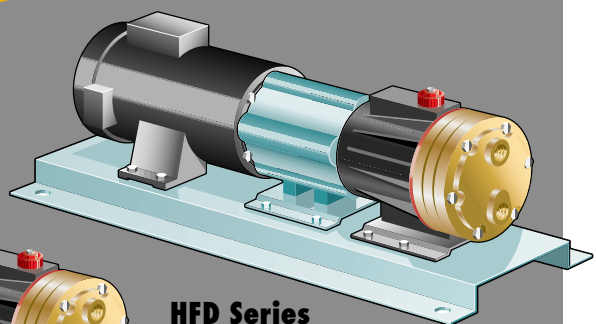

HFD Series
Horizontal flanged adapter drive

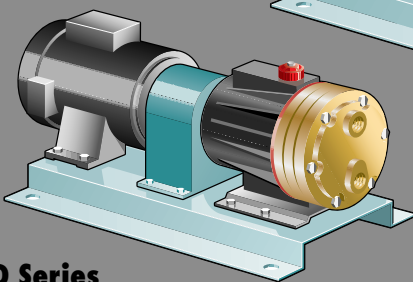

HDD Series
Horizontal direct drive

Construction

D10 Bases and guards are contour formed for maximum strength and safety. Steel thickness from 10 to 7 gauge.

H25 Heavy duty contour formed and welded reinforced design. All steel plate 3/16" thick.

H25 Heavy duty contour formed and welded reinforced design. All steel plate 1/4" thick.

- Baseplates and guards available in blue epoxy powder coated steel or Grade 303 stainless steel
- Pump, motor, adjustable motor base, coupling, flange adapter, pulleys and belt ordered separately
- Belt guards are flattened expanded metal half inch mesh

HDD Series Horizontal direct drive

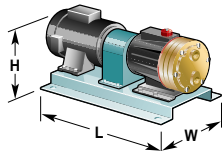

Baseplate Includes:

- Mounting hardware
- Set of shims
- Coupling guard

HFD Series Horizontal flanged adapter drive

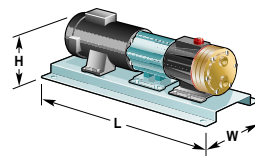

Baseplate Includes:

- Mounting hardware

HBD Series Horizontal belt drive w/guard

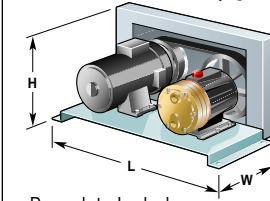

Baseplate Includes:

- Mounting hardware
- Belt pulley guard

VBD Series Vertical belt drive w/guard

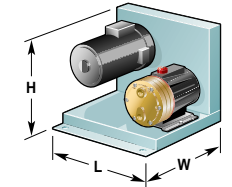

Baseplate Includes:

- Mounting hardware
- Belt pulley guard

Required Motor Information

	Motor Frame Size	Shaft Size	Dimensions			Dimensions			Dimensions			Dimensions		
			Order Number		L x W x H (inches)	Order Number		L x W x H (inches)	Order Number		L x W x H (inches)	Order Number		L x W x H (inches)
			Steel	SST		Steel	SST		Steel	SST		Steel	SST	
D-10 Pump shaft Ø: 7/8"	56C	5/8	104-050	104-051	21x11x11	104-052	104-053	21x11x11	104-150	104-151	23x14x12	104-250	104-251	16x19x24
	143T	7/8	104-050	104-051	21x11x11	104-052	104-053	21x11x11	104-150	104-151	23x14x12	104-250	104-251	16x19x24
	145T	7/8	104-050	104-051	21x11x11	104-052	104-053	21x11x11	104-150	104-151	23x14x12	104-250	104-251	16x19x24
	182T	1-1/8	104-000	104-001	22x13x10	104-002	104-003	22x13x12	104-100	104-101	29x16x14	104-200	104-201	21x22x27
	184T	1-1/8	104-000	104-001	22x13x10	104-002	104-003	22x13x12	104-100	104-101	29x16x14	104-200	104-201	21x22x27
	213T	1-3/8	104-030	104-031	25x14x13	104-032	104-033	25x14x13	104-100	104-101	29x16x14	104-200	104-201	21x22x27
	215T	1-3/8	104-030	104-031	25x14x13	104-032	104-033	25x14x13	104-100	104-101	29x16x14	104-200	104-201	21x22x27
H-25 Pump shaft Ø: 1-1/8"	213T	1-3/8	-	-	-	-	-	-	104-400	104-401	39x24x17	-	-	-
	215T	1-3/8	-	-	-	-	-	-	104-400	104-401	39x24x17	-	-	-
	254T	1-5/8	104-300	104-301	38x18x15	-	-	-	104-400	104-401	39x24x17	-	-	-
	256T	1-5/8	104-300	104-301	38x18x15	-	-	-	-	-	-	-	-	-
D-35 Pump shaft Ø: 2"	284T	1-7/8	104-300	104-301	38x18x15	-	-	-	-	-	-	-	-	-
	254T	1-5/8	-	-	-	-	-	-	104-700	104-701	40x28x19	-	-	-
	256T	1-5/8	-	-	-	-	-	-	104-700	104-701	40x28x19	-	-	-
	284T	1-7/8	104-600	104-601	48x20x18	-	-	-	104-700	104-701	40x28x19	-	-	-
	286T	1-7/8	104-600	104-601	48x20x18	-	-	-	104-700	104-701	40x28x19	-	-	-
	324T	2-1/8	104-600	104-601	48x20x18	-	-	-	-	-	-	-	-	-
326T	2-1/8	104-600	104-601	48x20x18	-	-	-	-	-	-	-	-	-	



Wanner Engineering, Inc.

1204 Chestnut Avenue, Minneapolis, MN 55403 USA

(612) 332-5681 FAX (612) 332-6937

Toll Free FAX (USA only) (800) 332-6812

Email: sales@wannereng.com

Website: www.hydra-cell.com

Document Fax Back System: (510) 745-0440



Wanner International Ltd.

Grange Court, Grange Road

Tongham, Surrey GU10 1DW, England

Tel +44 (0) 1252 781234

FAX Tel +44 (0) 1252 781235

Email: sales@wannerint.com