

# SD Series

## Slurry Duty Pumps

Hydra-Cell Slurry Duty pumps are specifically designed for abrasive duty applications in order to:

- Increase flow
- Reduce and simplify maintenance
- Extend pump life
- Provide quiet operation, and repeatable, consistent positive displacement output

Hydra-Cell Slurry Duty Pumps are ideal for harsh abrasive slurries such as:

- Alumina
- Bentonite
- Carbon
- Clay
- Fly ash
- Ink
- Lime slurry
- Paint and pigments

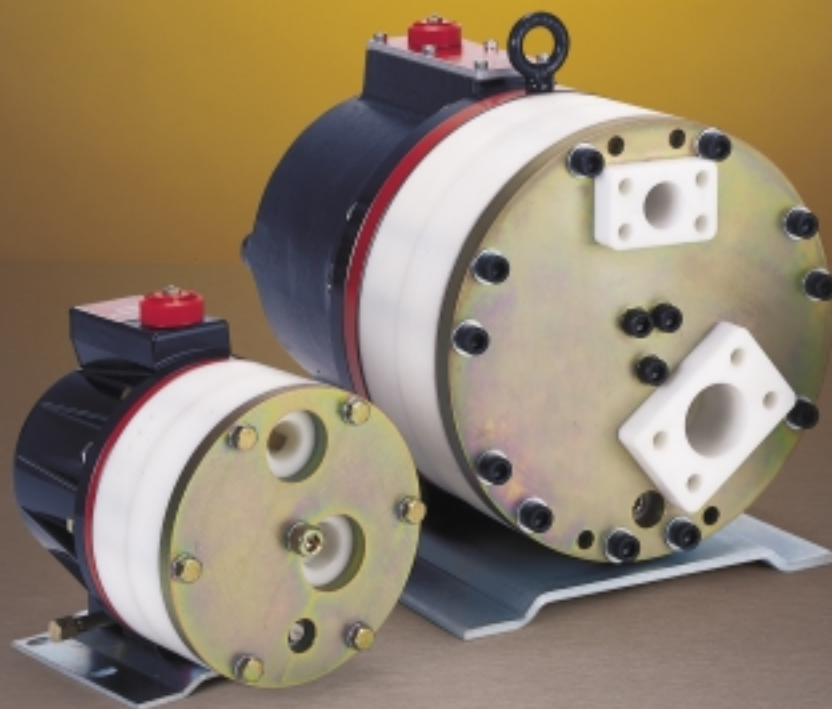

*Hydra-Cell*<sup>®</sup>  
SIMPLY BUILT TO LAST

# SD Series Slurry Duty

## flow

model	max flow		max input rpm
	gpm	l/min	
D-10-X	8	30.3	1450
D-10-E	8	30.3	1750
H-25-X	20	75.7	1050
H-25-E	20	75.7	1150
D-35-X	37	140	1050
D-35-E	35	132	1150

## pressure

**Maximum Inlet Pressure:**  
50 psi (3.5 bar)

**Pressure Variable To:**  
300 psi (21 bar)

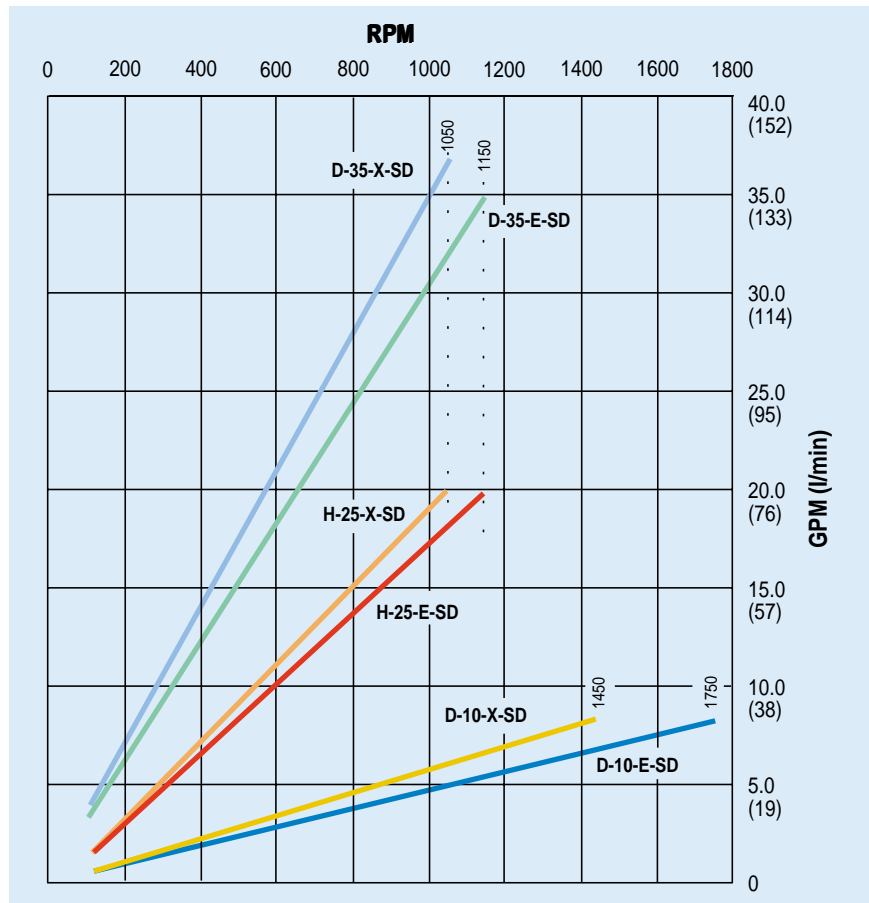

## Slurry Duty Case Study

A waste-to-energy incineration plant uses a 5% lime slurry concentration for flue-gas desulfurization as well as for cooling the emissions of the stack scrubbers. In order to speed the cleaning process, they experimented with a 20% lime slurry concentration. The results were excellent, but the existing progressing-cavity pump could not handle the increased solids. With the high cost of replacing the mechanical seal, rotor and stator, they were forced to look at an alternative pump. The Hydra-Cell Slurry Duty pump was chosen for its seal-less design and because it can handle the harsh abrasives.



The results were astounding. Not only did the Hydra-Cell Slurry Duty Pump easily handle the increased lime concentration, but

it also significantly reduced overall maintenance costs.

# SD Series Slurry Duty

## Maximum Capacity

	rpm	gpm	l/min
D-10-X-SD	1450	8	30.3
D-10-E-SD	1750	8	30.3
H-25-X-SD	1050	20	75.7
H-25-E-SD	1150	20	75.7
D-35-X-SD	1050	37	140
D-35-E-SD	1150	35	132

## Delivery @ max pressure

	revs/gal	revs/liter
D-10-X-SD	185	49
D-10-E-SD	219	58
H-25-X-SD	52	14
H-25-E-SD	58	15
D-35-X-SD	29	7.7
D-35-E-SD	31	8.2

<b>Max Inlet Pressure</b>	50 psi (3.5 bar)
---------------------------	------------------

<b>Discharge Pressure</b>	
Minimum	50 psi (3.5 bar)
Maximum	300 psi (21 bar)

<b>Max Temperature</b>	
Pump Head	140°F (60°C)
Hydraulic End	180°F (82°C)

<b>Inlet Port</b>	
D-10-SD:	1 inch NPT
H-25-SD:	1-1/2 inch NPT
D-35-SD:	2 inch SAE flange

<b>Discharge Port</b>	
D-10-SD:	3/4 inch NPT
H-25-SD:	1 inch NPT
D-35-SD:	1-1/4 inch SAE flange

<b>Shaft Diameter</b>	
D-10-SD:	7/8 inch
H-25-SD:	1-1/8 inch
D-35-SD:	2 inch

<b>Shaft Rotation</b>	Bi-directional
-----------------------	----------------

<b>Bearings</b>	Tapered roller
-----------------	----------------

<b>Oil Capacity</b> (see page 88 for oil selection and specification)	
D-10-SD:	1.1 US quart (1.05 liters)
H-25-SD:	2-1/2 US quarts (2.4 liters)
D-35-SD:	5 US quarts (4.7 liters)

<b>Weight</b>	
D-10-SD:	40 lbs (18 kg)
H-25-SD:	90 lbs (41 kg)
D-35-SD:	195 lbs (89 kg)

## Net Positive Suction Head (NPSHr)

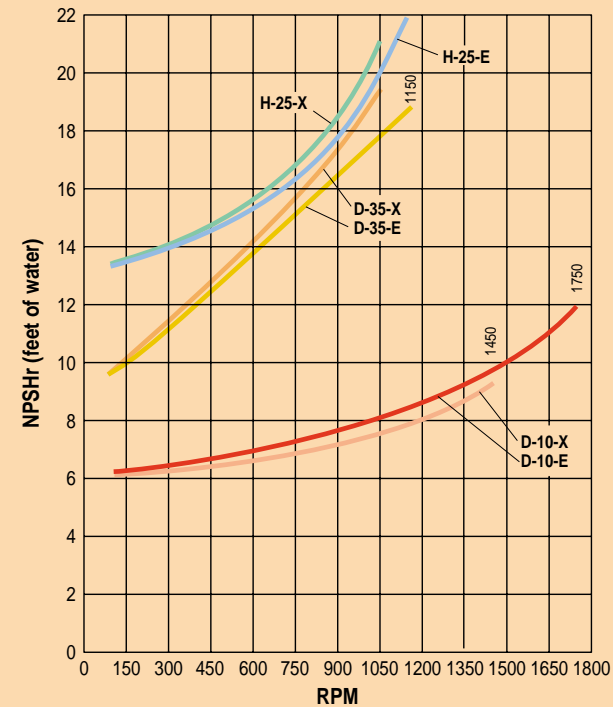

## Calculating Required Horsepower

D-10-SD:

$$\frac{15 \times \text{rpm}}{63,000} + \frac{\text{gpm} \times \text{psi}}{1,460} = \text{electric motor HP}$$

H-25-SD:

$$\frac{50 \times \text{rpm}}{63,000} + \frac{\text{gpm} \times \text{psi}}{1,460} = \text{electric motor HP}$$

D-35-SD:

$$\frac{100 \times \text{rpm}}{63,000} + \frac{\text{gpm} \times \text{psi}}{1,460} = \text{electric motor HP}$$

For installation guidelines and other pump selection design considerations, refer to pages 92-95.

# SD Series Slurry Duty

## SD Series Design Advantages

In abrasive slurry mixtures, all valve assembly components are critical to valve reliability. The Hydra-Cell Slurry Duty design is intended for improved abrasion resistance over standard "abrasive duty" pumps which have a ceramic valve and valve seat.

The unique Hydra-Cell Slurry Duty valve design eliminates relative movement between the valve assembly components.

- Crush seal preloads valve assembly
- Ground, balanced spring design
- Valve seat O-ring groove is 100% filled
- Polyurethane wear washers at spring ends

The hard valve "poppet" seals to relatively soft, elastic valve seat to resist abrasion

- The seat absorbs and releases abrasive particles
- Large sealing surface ensures reliability and minimizes stresses

Standard Valve

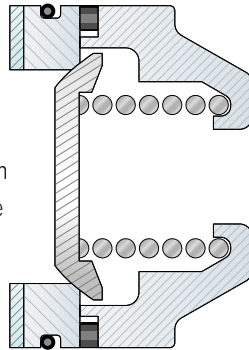

Slurry Valve\*

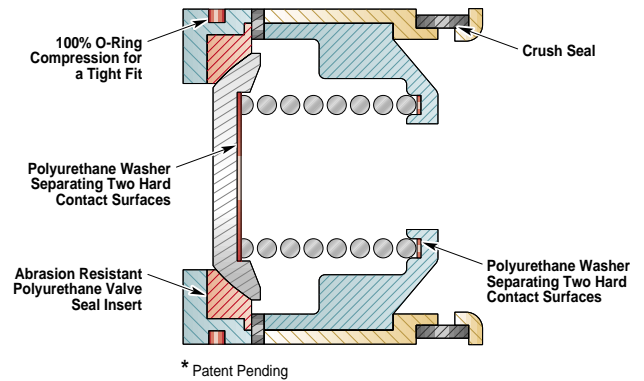

## D-10-SD 8 gpm with NPT inlet/outlet ports

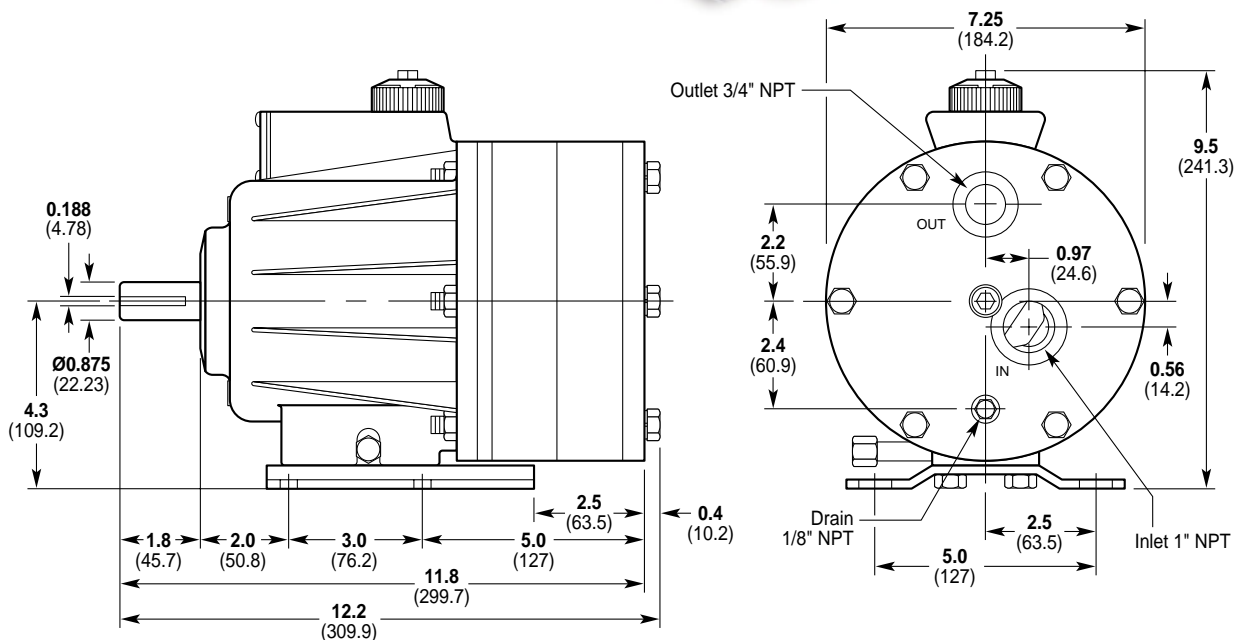

# SD Series **Slurry Duty**

H-25-SD 20 gpm with NPT inlet/outlet ports

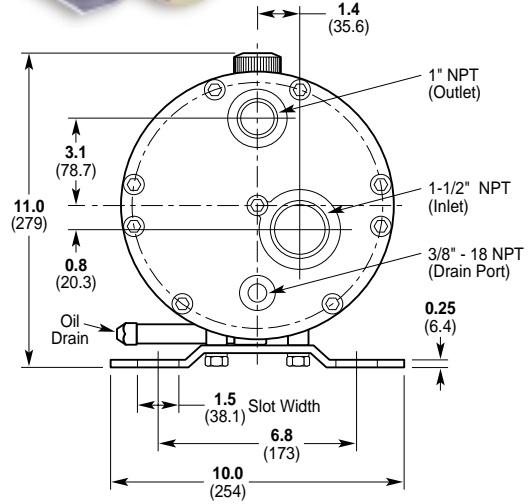
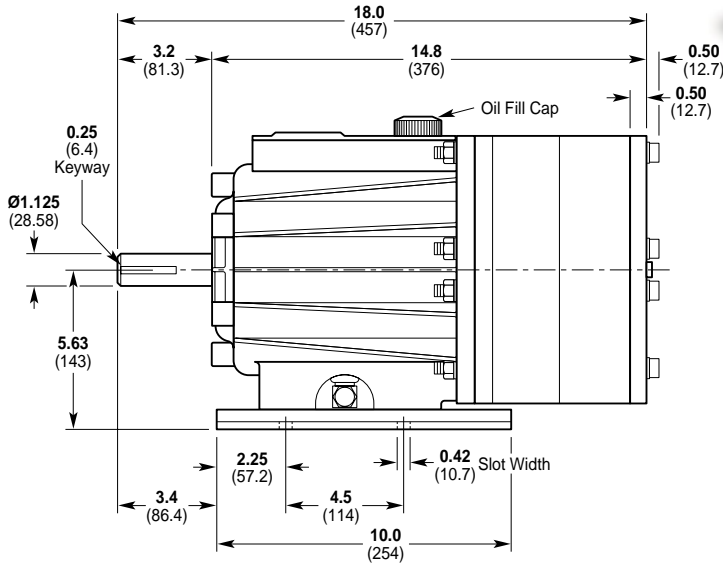

D-35-SD 35 gpm with SAE inlet/outlet ports

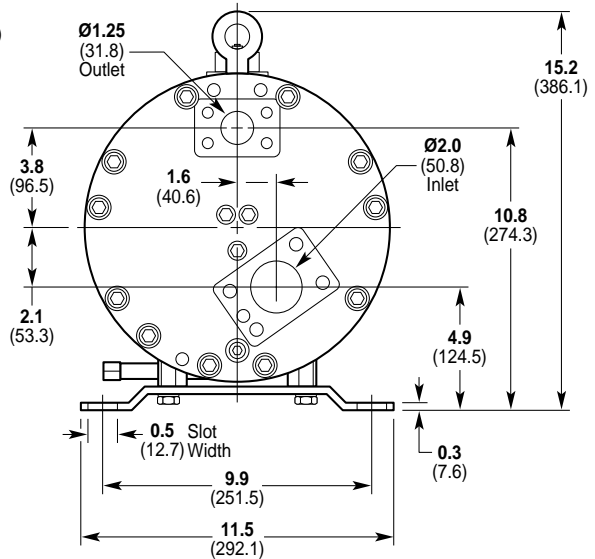
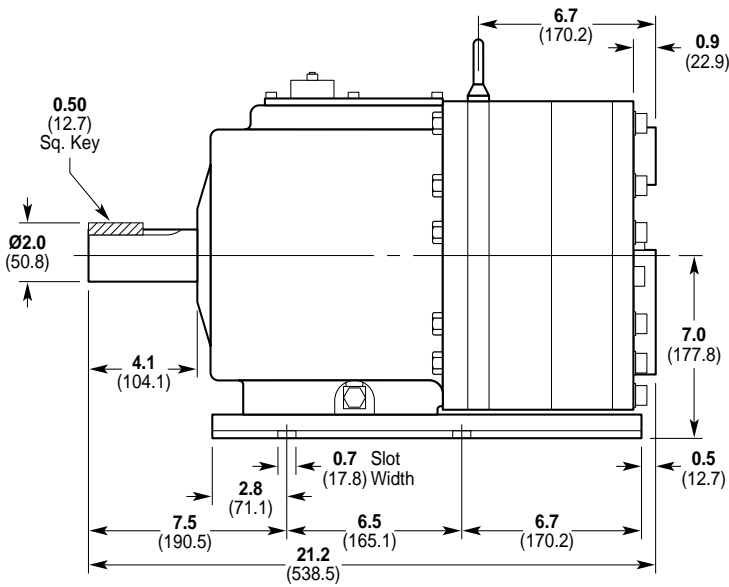
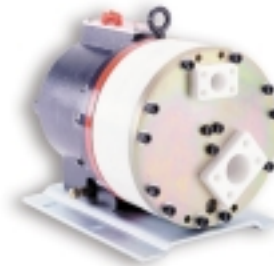

# SD Series How To Order

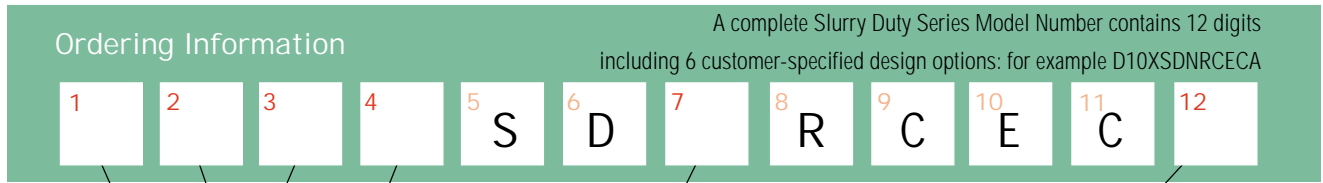

**1 2 3 Configuration**

- D10 (see page 71)
- H25 (see page 71)
- D35 (see page 71)

**4 Hydraulic End Cam**

- X (see page 71)
- E (see page 71)

**7 Diaphragm & O-ring Material**

- E EPDM (requires 30 wt EPDM-compatible hydraulic end oil)
- G Viton®-XT
- N Buna-N
- P Neoprene
- T Buna-N-XS



**12 Hydra-Oil**

- A 10W30 standard duty oil
- B 40-wt standard duty oil
- C 30-wt EPDM-compatible oil
- E 30-wt food-contact oil
- G 5W30 synthetic oil

**Materials of Construction**

<b>Pump Head</b>	Delrin
<b>Valve Seat</b>	Urethane and stainless steel
<b>Valves</b>	Ceramic
<b>Valve Springs</b>	Elgiloy®
<b>Valve Spring Retainer</b>	Celcon®

**Options, Accessories and Custom Designs**

- Valves, page 78
- Hydra-Oil, page 88
- Couplers, page 87
- Tool Kits, page 90

