

**INSTALLATION & SERVICE**

# **Hydra-Cell<sup>®</sup>** **INDUSTRIAL PUMPS**

**MODELS: H-25, G-25**

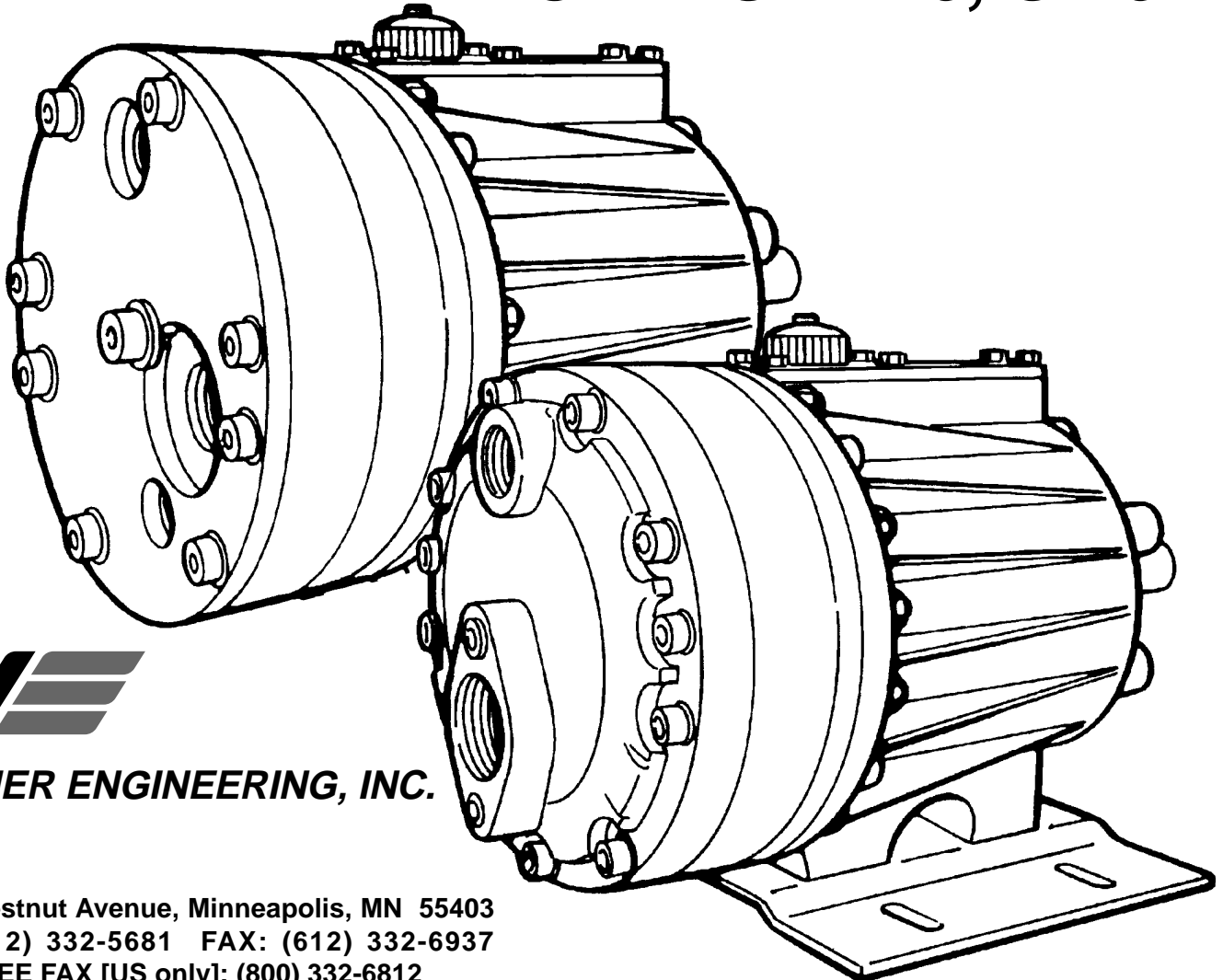

**WANNER ENGINEERING, INC.**

1204 Chestnut Avenue, Minneapolis, MN 55403  
TEL: (612) 332-5681 FAX: (612) 332-6937  
TOLL-FREE FAX [US only]: (800) 332-6812

[www.hydra-cell.com](http://www.hydra-cell.com)  
email: [sales@wannereng.com](mailto:sales@wannereng.com)  
Document Fax Back System: (510) 745-0440

# H-25/G-25 Contents

	Page
Specifications .....	2
Dimensions .....	4
Installation .....	5
Maintenance .....	9
Service (Fluid End) .....	10
Service (Hydraulic End) .....	15
Troubleshooting .....	18

## H-25/G-25 Specifications

### Maximum Capacity

	rpm	gpm	l/min
H/G-25-X	1050	20	75.7
H/G-25-E	1150	20	75.7
H/G-25-S	1150	16	60.6
H/G-25-I	1150	12	45.4

### Delivery @ max pressure

	revs/gal	revs/liter
H/G-25-X	52	14
H/G-25-E	58	15
H/G-25-S	72	19
H/G-25-I	96	25

**Max Inlet Pressure** 250 psi (17.3 bar)

### Pressure Variable to

Metallic:	1000 psi (69 bar)
Non-Metallic:	250 psi (17.3 bar)

**Max Temperature** 250°F (121°C) – consult factory for temperatures above 180°F (82°C)

**Inlet Port**  
H-25: 1-1/2 inch NPT  
G-25: 1-1/2 inch BSPT

**Discharge Port**  
H-25: 1 inch NPT  
G-25: 1 inch BSPT

**Shaft Diameter** 1-1/8 inch (28.58 mm)

**Shaft Rotation** Bi-directional

**Bearings** Tapered roller

**Oil Capacity** 2-1/2 US quarts (2.4 liters)

### Weight

Metallic Heads:	125 lbs (56.8 kg)
Non-Metallic Heads:	90 lbs (40.9 kg)

### Calculating Required Horsepower

$$\frac{50 \times \text{rpm}}{63,000} + \frac{\text{gpm} \times \text{psi}}{1,460} = \text{electric motor HP}^*$$

$$\frac{50 \times \text{rpm}}{84,428} + \frac{\text{lpm} \times \text{bar}}{511} = \text{electric motor kW}^*$$

\* HP and kW required for electric motors; must be at rpm used in calculation. Consult engine manufacturer for gasoline or diesel power requirements.

# H-25/G-25 Specifications – Continued

## Performance

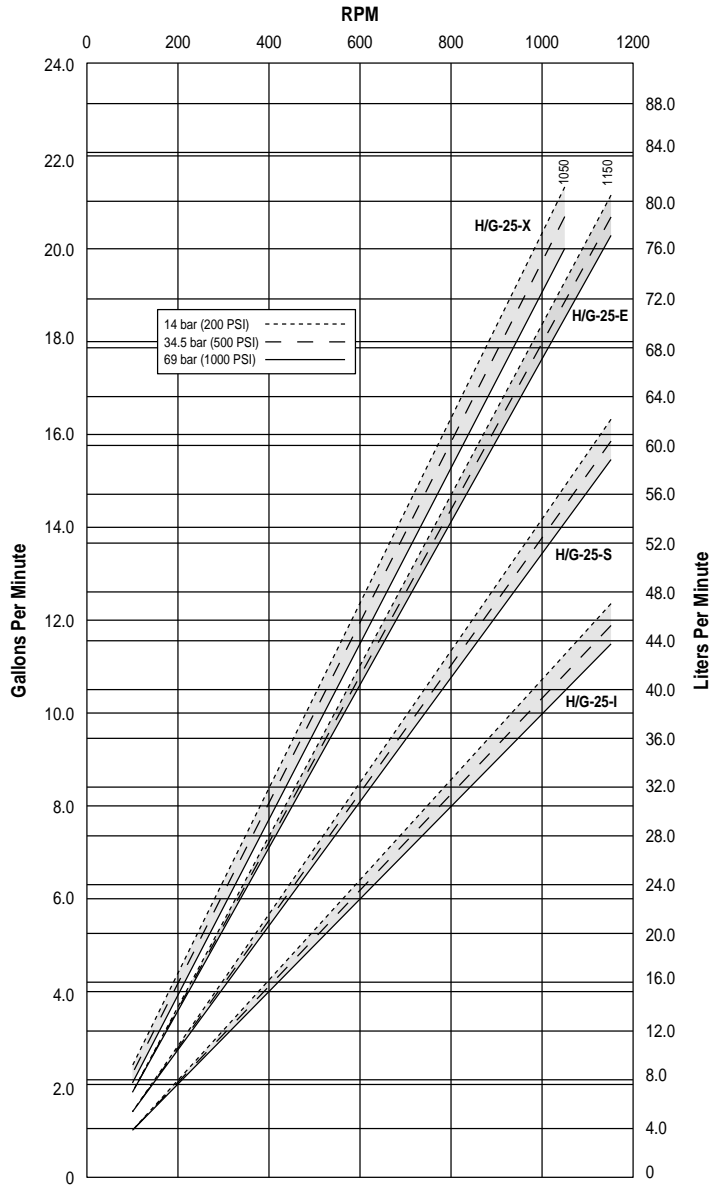

## Net Positive Suction Head – NPSHr

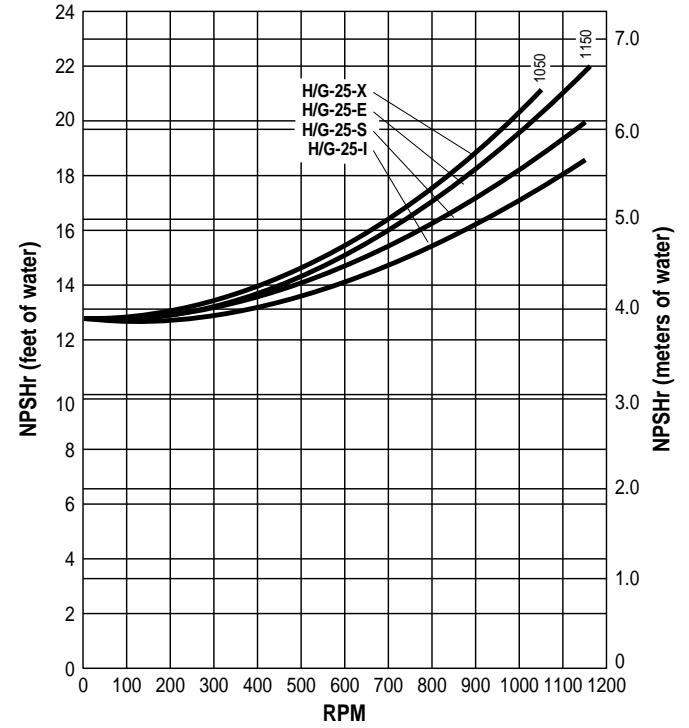

## Dry Lift

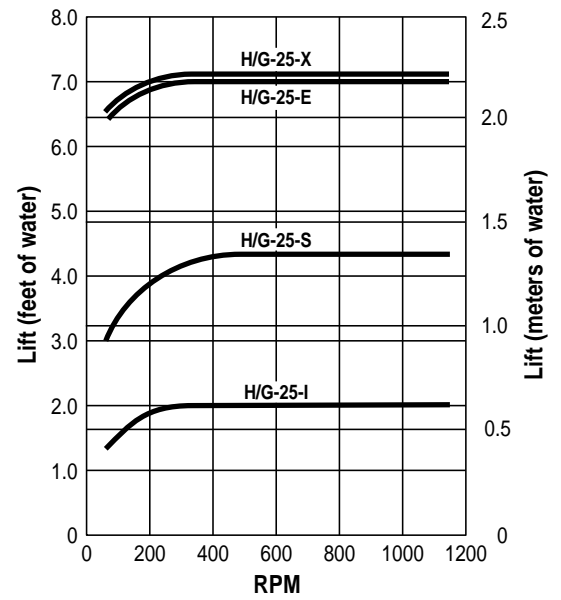

# H-25/G-25 Dimensions

## Models with Metallic Pumping Head

- Brass
- Cast Iron
- 316 Stainless Steel
- Nickel Alloy (C Series)

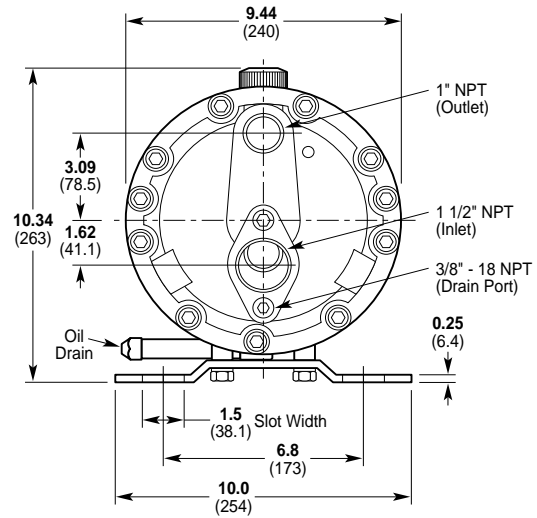
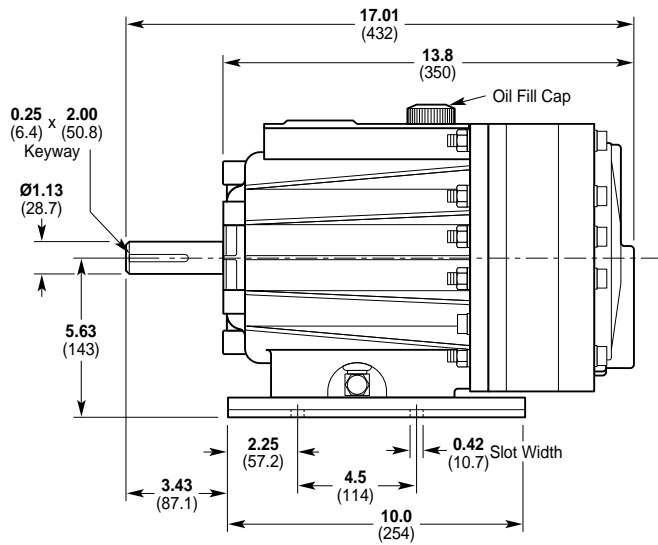

## Models with Non-metallic Pump Head

- Kynar®
- Polypropylene

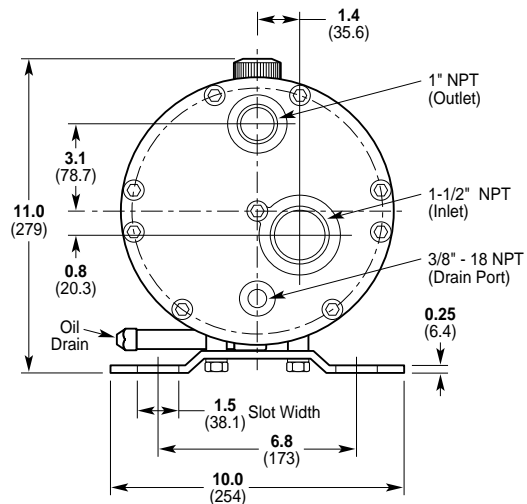
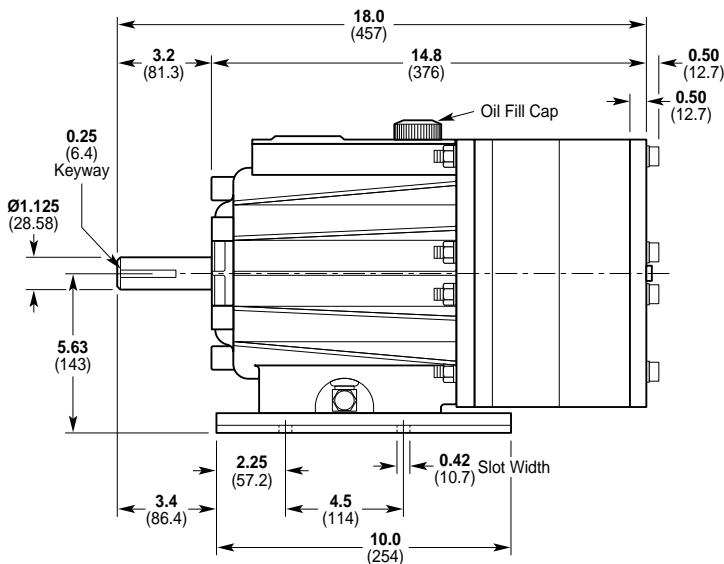

# H-25/G-25 Installation

## Location

**NOTE:** The numbers in parentheses are the Reference Numbers on the exploded view illustrations found later in this manual and in the Parts Manual.

Locate the pump as close to the supply source as possible.

Install it in a lighted, clean space where it will be easy to inspect and maintain. Allow room for checking the oil level, changing the oil, and removing the pump head (manifold, valve plate and related items).

## Mounting

The pump shaft can be rotated in either direction.

To prevent vibration, securely attach the pump and motor to a level, rigid base.

On a belt-drive system, align the sheaves accurately: poor alignment wastes horsepower and shortens the belt and bearing life. Make sure the belts are properly tightened, as specified by the belt manufacturer.

On a direct-drive system, align the shafts accurately. Unless otherwise specified by the coupling manufacturer, maximum parallel misalignment should not exceed 0.015 in. (0.4 mm) and angular misalignment should be held to 1° maximum. Careful alignment extends life of the coupling, pump, shafts, and support bearings. Consult coupling manufacturer for exact alignment tolerances.

## Important Precautions

**Adequate Fluid Supply.** To avoid cavitation and premature pump failure, be sure that the pump will have an adequate fluid supply and that the inlet line will not be obstructed. See "Inlet Piping".

**Positive Displacement.** This is a positive-displacement pump. To avoid severe system damage if the discharge line ever becomes blocked, install a relief valve downstream from the pump. See "Discharge Piping".

**Safety Guards.** Install adequate safety guards over all pulleys, belts, and couplings. Follow all codes and regulations regarding installation and operation of the pumping system.

**Shut-Off Valves.** Never install shut-off valves between the pump and discharge pressure regulator, or in the regulator bypass line.

**Freezing Conditions.** Protect the pump from freezing. See also the Maintenance Section.

Consult the Factory for the following situations:

- Extreme temperature applications – above 160° F (71° C) or below 40° F (5° C)
- Pressure feeding of pumps
- Viscous or abrasive fluid applications
- Chemical compatibility problems
- Hot ambient temperatures – above 110° F (43° C)
- Conditions where pump oil may exceed 200° F (93° C) because of a combination of hot ambient temperatures, hot fluid temperature, and full horsepower load — an oil cooler may be required.

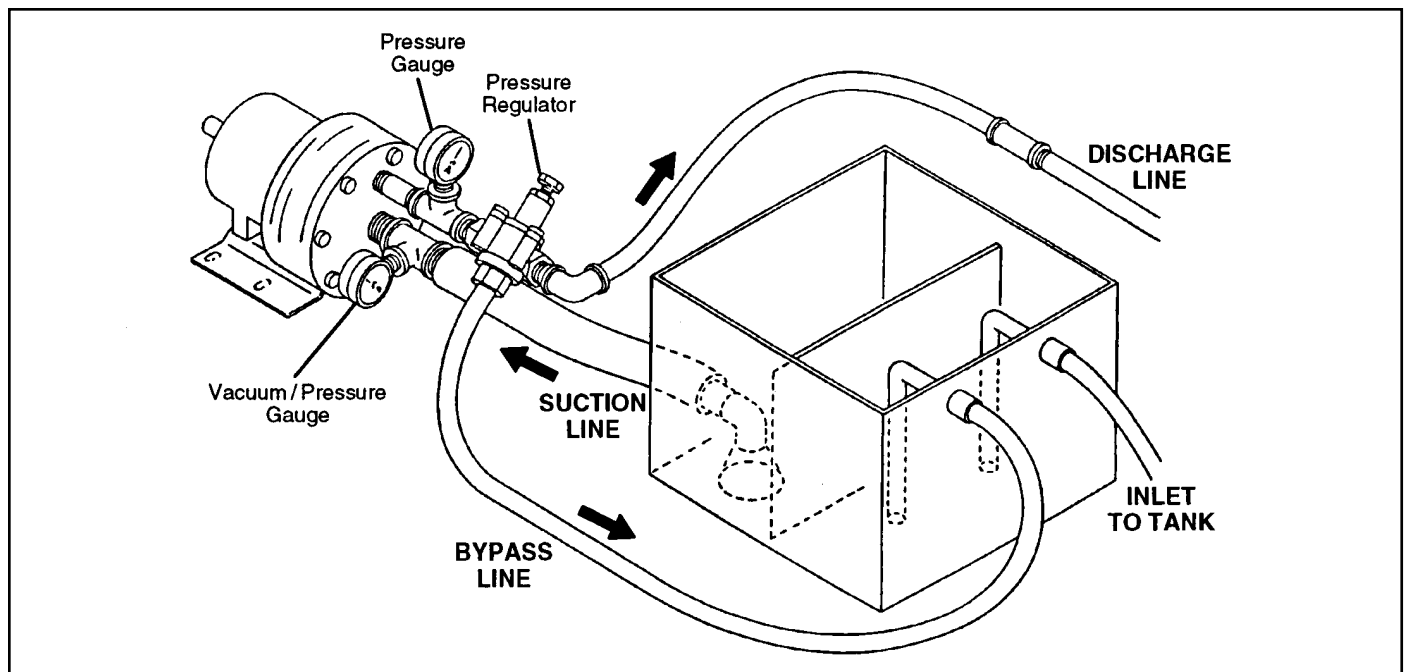

# H-25/G-25 Installation – Continued

## Inlet Piping (Suction Feed)

**CAUTION: When pumping at temperatures above 160° F (71° C), use a pressure-feed system.**

Install draincocks at any low points of the suction line, to permit draining in freezing conditions.

Provide for permanent or temporary installation of a vacuum gauge to monitor the inlet suction. To maintain maximum flow, vacuum at the pump inlet should not exceed 7 in. Hg at 70° F (180 mm Hg at 21° C). **Do not supply more than one pump from the same inlet line.**

### Supply Tank

Use a supply tank that is large enough to provide time for any trapped air in the fluid to escape. The tank size should be at least twice the maximum pump flow rate.

Isolate the pump and motor stand from the supply tank, and support them separately.

Install a separate inlet line from the supply tank to each pump.

Install the inlet and bypass lines so they empty into the supply tank below the lowest water level, on the opposite side of the baffle from the pump suction line.

If a line strainer is used in the system, install it in the inlet line to the supply tank.

To reduce aeration and turbulence, install a completely submerged baffle plate to separate the incoming and outgoing liquids.

Install a vortex breaker in the supply tank, over the outlet port to the pump.

Place a cover over the supply tank, to prevent foreign objects from falling into it.

### Hose and Routing

Size the suction line at least one size larger than the pump inlet, and so that the velocity will not exceed 1-3 ft/sec (0.3 to 0.9 m/s):

For pipe in inches:  $\text{Velocity (ft/sec)} = 0.408 \times \text{GPM/Pipe ID}^2$

For pipe in mm:  $\text{Velocity (m/sec)} = 21.2 \times \text{LPM/Pipe ID}^2$

Keep the suction line as short and direct as possible. A maximum of 3 feet (1 m) is recommended.

Use flexible hose and/or expansion joints to absorb vibration, expansion, or contraction.

If possible, keep the suction line level. Do not have any high points to collect vapor unless these high points are vented.

To reduce turbulence and resistance, do not use 90° elbows. If turns are necessary in the suction line, use 45° elbows or arrange sweeping curves in the flexible inlet hose.

If a block valve is used, be sure it is fully opened so that the flow to the pump is not restricted. The opening should be at least the same diameter as the inlet plumbing ID.

Do not use a line strainer or filter in the suction line unless regular maintenance is assured. If used, it should have a free-flow area of at least three times the free-flow area of the inlet.

Install piping supports where necessary to relieve strain on the inlet line and to minimize vibration.

Loctite is a registered trademark of Loctite Corporation.  
Teflon is a registered trademark of E. I. DuPont de Nemours & Co. Inc.  
Scotchbrite is a registered trademark of 3M Company.

## Inlet Piping (Pressure Feed)

Provide for permanent or temporary installation of a vacuum/pressure gauge to monitor the inlet vacuum or pressure. Pressure at the pump inlet should not exceed 250 psi (17 bar); if it could get higher, install an inlet pressure reducing regulator.

Do **not** supply more than one pump from the same inlet line.

## Inlet Calculations

### Acceleration Head

#### Calculating the Acceleration Head

Use the following formula to calculate acceleration head losses. Subtract this figure from the NPSHa, and compare the result to the NPSHr of the Hydra-Cell pump.

$$H_a = (L \times V \times N \times C) \div (K \times G)$$

where:

H<sub>a</sub> = Acceleration head (ft of liquid)

L = Actual length of suction line (ft) — not equivalent length  
V = Velocity of liquid in suction line (ft/sec) [ $V = \text{GPM} \times (0.408 \div \text{pipe ID}^2)$ ]

N = RPM of crank shaft

C = Constant determined by type of pump — use 0.066 for the H-25 and G-25 Hydra-Cell pumps

K = Constant to compensate for compressibility of the fluid — use: 1.4 for de-aerated or hot water; 1.5 for most liquids; 2.5 for hydrocarbons with high compressibility

G = Gravitational constant (32.2 ft/sec<sup>2</sup>)

### Friction Losses

#### Calculating Friction Losses in Suction Piping

When following the above recommendations (under “Inlet Piping”) for minimum hose/pipe I.D. and maximum length, frictional losses in the suction piping are negligible (i.e., H<sub>f</sub> = 0) if you are pumping a water-like fluid.

When pumping more-viscous fluids such as lubricating oils, sealants, adhesives, syrups, varnishes, etc., frictional losses in the suction piping may become significant. As H<sub>f</sub> increases, the available NPSH (NPSHa) will decrease, and cavitation will occur.

In general, frictional losses increase with increasing viscosity, increasing suction-line length, increasing pump flowrate, and decreasing suction-line diameter. Changes in suction-line diameter have the greatest impact on frictional losses: a 25% increase in suction-line diameter cuts losses by more than two times, and a 50% increase cuts losses by a factor of five times.

Consult the factory before pumping viscous fluids.

#### Minimizing Acceleration Head and Frictional Losses

To minimize the acceleration head and frictional losses:

- Keep inlet lines less than 3 ft (1 m) long
- Use at least 1-1/2 in. (38 mm) I.D. inlet hose
- Use soft hose (low-pressure hose, noncollapsing) for the inlet lines
- Minimize fittings (elbows, valves, tees, etc.)
- **Use a suction stabilizer on the inlet.**

# H-25/G-25 Installation – Continued

## Net Positive Suction Head

NPSHa must be equal to or greater than NPSHr. If not, the pressure in the pump inlet will be lower than the vapor pressure of the fluid — and cavitation will occur.

### Calculating the NPSHa

Use the following formula to calculate the NPSHa:

$$\text{NPSHa} = P_t + H_z - H_f - H_a - P_{vp}$$

where:

$P_t$  = Atmospheric pressure

$H_z$  = Vertical distance from surface liquid to pump centerline (if liquid is below pump centerline, the  $H_z$  is negative)

$H_f$  = Friction losses in suction piping

$H_a$  = Acceleration head at pump suction

$P_{vp}$  = Absolute vapor pressure of liquid at pumping temperature

NOTES:

- In good practice, NPSHa should be 2 ft greater than NPSHr
- All values must be expressed in feet of liquid

### Atmospheric Pressure at Various Altitudes

Altitude (ft)	Pressure (ft of H <sub>2</sub> O)	Altitude (ft)	Pressure (ft of H <sub>2</sub> O)
0	33.9	1500	32.1
500	33.3	2000	31.5
1000	32.8	5000	28.2

## Discharge Piping

**NOTE: Consult the Factory before manifolding two or more pumps together.**

### Hose and Routing

Use the shortest, most-direct route for the discharge line.

Select pipe or hose with a **working pressure** rating of at least 1.5 times the maximum system pressure. **EXAMPLE:** Select a 1500-psi W.P.-rated hose for systems to be operated at 1000-psi-gauge pressure.

Use about 6 ft (1.8 m) of flexible hose between the pump and rigid piping to absorb vibration, expansion or contraction.

Support the pump and piping independently. Size the discharge line so that the velocity of the fluid will not exceed 7-10 ft/sec (2-3 m/sec):

For pipe in inches: Velocity (ft/sec) =  $0.408 \times \text{GPM}/\text{Pipe ID}^2$

For pipe in mm: Velocity (m/sec) =  $21.2 \times \text{LPM}/\text{Pipe ID}^2$

### Pressure Regulation

**Install a pressure regulator or unloader in the discharge line.** Bypass pressure must not exceed the pressure limit of the pump.

Size the regulator so that, when fully open, it will be large enough to relieve the full capacity of the pump without overpressurizing the system.

Locate the valve as close to the pump as possible and ahead of any other valves.

Adjust the pressure regulating valve to no more than 10% over the maximum working pressure of the system. Do not exceed the manufacturer's pressure rating for the pump or regulator.

Route the bypass line to the supply tank, or to the suction line as far as possible from the pump (to reduce the chance of turbulence and cavitation).

If the pump may be run for a long time with the discharge closed and fluid bypassing, install a thermal protector in the bypass line (to prevent severe temperature buildup in the bypassed fluid).

**CAUTION: Never install shutoff valves in the bypass line or between the pump and pressure regulator or relief valve.**

Provide for permanent or temporary installation of a pressure gauge to monitor the discharge pressure at the pump.

For additional system protection, install a safety relief valve in the discharge line, downstream from the pressure regulator.

# H-25/G-25 Installation – Continued

---

## Before Initial Start-Up

Before you start the pump, be sure that:

- All shutoff valves are open, and the pump has an adequate supply of fluid.
- All connections are tight.
- The oil level is 1/4 in. (6 mm) above the cast surface in the upper oil reservoir.
- The relief valve on the pump outlet is adjusted so the pump starts under minimum pressure.
- All pulleys and belts are properly aligned, and belts are tensioned according to specification.
- All pulleys, belts and shaft couplings have adequate safety guards.

## Initial Start-Up Procedure

1. Turn on power to the pump motor.
2. Check the inlet pressure or vacuum. To maintain maximum flow, inlet vacuum must not exceed 7 in. Hg at 70° F (180 mm Hg at 21° C). Inlet pressure must not exceed 250 psi (17 bar).
3. Listen for any erratic noise, and look for unsteady flow. If the pump does not clear, refer to the Troubleshooting Section.
4. If the system has an air lock and the pump fails to prime:
  - a. Turn off the power.
  - b. Remove the pressure gauge or plug from the tee fitting at the pump outlet (refer to the illustration on page 5).

**NOTE: Fluid may come out of this port when the plug is removed. Provide an adequate catch basin for fluid spillage, if required. Fluid will come out of this port when the pump is started, so we recommend that you attach adequate plumbing from this port so fluid will not be sprayed or lost. Use high-pressure-rated hose and fittings from this port. Take all safety precautions to assure safe handling of the fluid being pumped.**

- c. Jog the system on and off until the fluid coming from this port is air-free.
  - d. Turn off the power.
  - e. Remove the plumbing that was temporarily installed, and reinstall the pressure gauge or plug.
5. Adjust the discharge pressure regulator to the desired operating and bypass pressures. Do not exceed the maximum pressure rating of the pump.
  6. After the pressure regulator is adjusted, set the safety relief valve at 100 psi (7 bar) higher than the desired operating pressure. To verify this setting, adjust the discharge pressure regulator upward until the relief valve opens. Follow the recommendations in the above NOTE (step 4b) for handling the fluid that will come from the relief valve.
  7. Reset the discharge pressure regulator to the desired system pressure.
  8. Provide a return line from the relief valve to the supply tank, similar to the bypass line from the pressure regulator.

# H-25/G-25 Maintenance

---

**NOTE:** The numbers in parentheses are the Reference Numbers on the exploded view illustrations found in this manual and in the Parts Manual.

## Daily

Check the oil level and the condition of the oil. The oil level should be 1/4 in. (6 mm) above the cast surface in the upper oil reservoir.

Use the appropriate Hydra-Oil for the application (contact Wanner Engineering if in doubt).

**CAUTION:** If you are losing oil but don't see any external leakage, or if the oil becomes discolored and contaminated, one of the diaphragms (22) may be damaged. Refer to the Fluid-End Service Section. Do not operate the pump with a damaged diaphragm.

**CAUTION:** Do not leave contaminated oil in the pump housing or leave the housing empty. Remove contaminated oil as soon as discovered, and replace it with clean oil.

## Periodically

Change the oil after the first 100 hours of operation, and every 1000 operating hours thereafter. When changing, remove the drain plug cap (34) at the bottom of the pump so all oil and accumulated sediment will drain out.

**CAUTION:** Do not turn the drive shaft while the oil reservoir is empty.

Check the inlet pressure or vacuum periodically with a gauge. If vacuum at the pump inlet exceeds 7 in. Hg (180 mm Hg), check the inlet piping system for blockages. If the pump inlet is located above the supply tank, check the fluid supply level and replenish if too low.

**CAUTION:** Protect the pump from freezing. Refer also to the "Shutdown Procedure".

## Shutdown Procedure During Freezing Temperatures

**Take all safety precautions to assure safe handling of the fluid being pumped. Provide adequate catch basins for fluid drainage and use appropriate plumbing from drain ports, etc. when flushing the pump and system with a compatible antifreeze.**

1. Adjust the discharge pressure regulating valve so the pump runs under minimum pressure. Stop the pump.
2. Drain supply tank; open any draincocks in system piping and collect drainage; remove plug (4) from manifold and collect drainage.
3. Close draincocks in system piping and replace manifold plug.
4. Fill supply tank with enough antifreeze to fill system piping and pump.

**NOTE:** Disconnect the system return line from the supply tank and connect it to a separate reservoir.

5. Start the pump and allow it to run until the system is filled with antifreeze. **NOTE: If the system has an airlock and the pump fails to prime, follow step 4 of the Initial Start-Up Procedure to clear the air.**
6. When mostly antifreeze is flowing from the system return line stop the pump. Connect the system return line back to the supply tank and circulate the antifreeze for a short period.
7. It is also good practice to change the oil in the hydraulic end before storage for an extended period. This will remove any accumulated condensation and sediment from the oil reservoir. Drain and refill the hydraulic end with the appropriate Hydra-Oil and operate the pump for a short period to assure smooth performance.

# H-25/G-25 Service (Fluid End)

## Models with Non-Metallic Pump Head

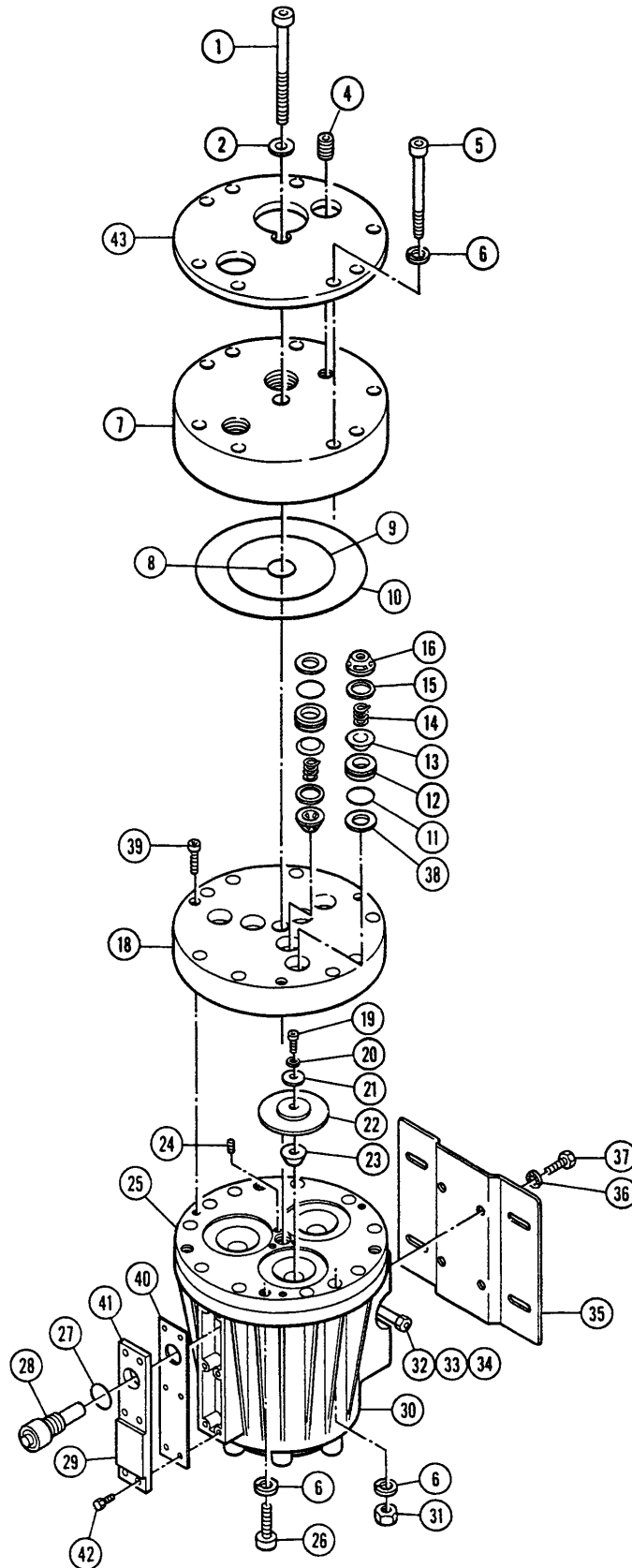

# H-25/G-25 Service (Fluid End) – Continued

## Models with Metallic Pumping Head

- ❖ With brass external-centerbolt models, use #8; with all other models, use #3.
- With cast iron pump heads, use #17 and not #10; with all other heads, use #10 and not #17.
- \* Not required on all pumps.

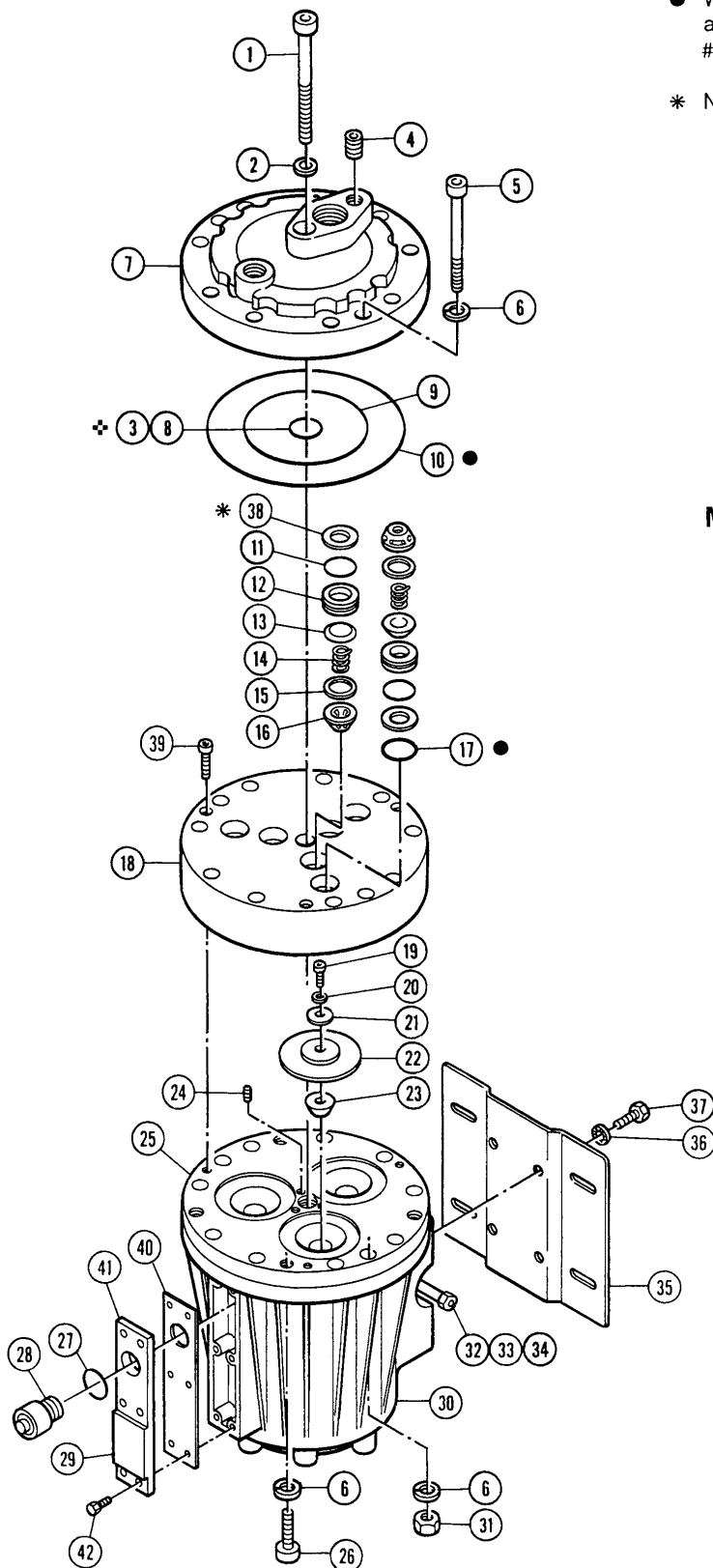

### VALVE ASSEMBLIES WITH METAL SPRING RETAINERS

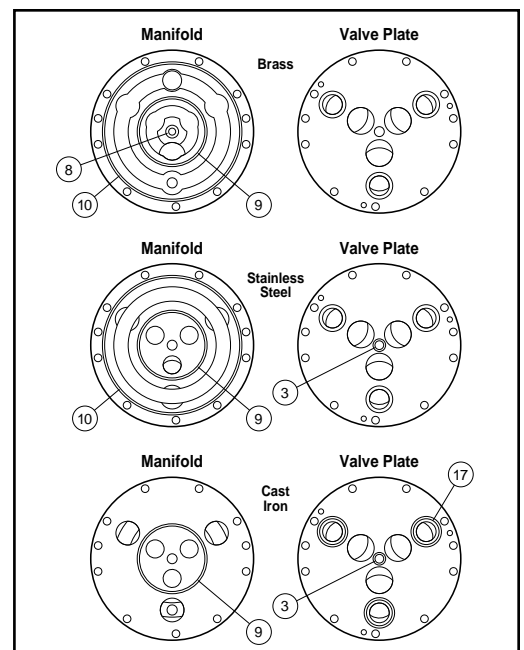
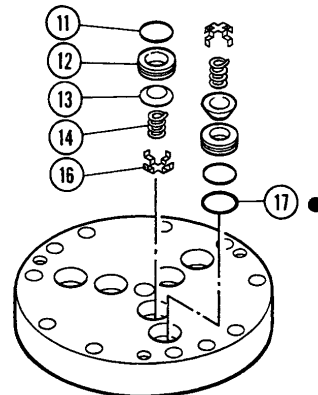

# H-25/G-25 Service (Fluid End) – Continued

**NOTE:** The numbers in parentheses are the Ref. Nos. on the illustrations in the Parts Manual.

This section explains how to disassemble and inspect all easily-serviceable parts of the pump. Repair procedures for the hydraulic end (oil reservoir) of the pump are included in a later section of the manual.

**CAUTION:** Do not disassemble the hydraulic end unless you are a skilled mechanic. For assistance, contact Wanner Engineering (TEL 612-332-5681 or FAX 612-332-6937) or the distributor in your area.

**CAUTION:** The four bolts (26) that screw through the back of the housing into the cylinder casting hold the casting over the hydraulic end of the pump. Do not remove them except when repairing the hydraulic end.

## 1. Remove Manifold (7), Valve Plate (18)

- Remove all nuts (31) and bolts (5) around the manifold. Do not remove the four bolts (26) that are installed through the back of the pump housing.
- With a 3/8-in (10-mm) hex Allen wrench, remove the centerbolt (1) and its washer (2) in the center of the manifold.

**CAUTION:** Do not turn the pump drive shaft while the manifold and valve plate are off the pump, except when removing diaphragms or repriming the hydraulic cells.

- Remove the manifold (7) and support plate (43). (Support plate (43) is used only with non-metallic pump head.)
- Inspect the manifold for warping or wear around the inlet and outlet ports. If wear is excessive, replace the manifold.  
To check if the manifold is warped, remove the O-rings and place a straightedge across it. A warped manifold should be replaced.
- Remove the three socket-head cap screws (39) with a 3/16-in. (5-mm) hex Allen wrench.
- Inspect the valve plate in the same manner as the manifold.

**NOTE:** Plastic valve plates and manifolds should also be inspected for cracks, and replaced if necessary.

## 2. Inspect Valves (11-16, 38)

The three inlet and three outlet valve assemblies in the pump are identical (but face in opposite directions). Inspect each valve as follows:

- Check the spring retainer (16), and replace if worn.
- Check the valve spring (14). If it is shorter than a new spring, replace it (don't just stretch the old spring).
- Check the valve poppet (13). If worn excessively, replace it.

**NOTE:** If your pump has plastic spring retainers, there is a tetra seal (flat O-ring, 15) between the retainer (16) and valve seat (12).

- Remove the valve seat (12). A seat remover is included in the Wanner Tool Kit. On cast iron valve plates, be careful not to break the metal ridge around the O-ring groove.

Inspect the valve seat for wear, and replace it if necessary. Install a new O-ring (11).

- Reinstall the valve assemblies:
  - Clean the valve ports and shoulders with emery cloth, and lubricate them with lubricating gel or petroleum jelly.
  - Install the O-ring (11) on the valve seat (12).

**NOTE:** Some pumps use plastic dampening washers (38) between the valve seat (12) and the manifold (7) or valve plate (18). Refer to the illustrations on page 11, and the fluid-end exploded views in the Parts Manual.

- Inlet (3 center valves).** Insert the spring retainer (16) into the valve plate, then insert the spring, valve, and valve seat (14,13,12). If the pump has **plastic** spring retainers, a flat O-ring (15) goes between the retainer and seat.
- Outlet (3 outer valves).** Insert the valve seat, valve, and spring, then the retainer. If the pump has **plastic** retainers, install the flat O-ring between the retainer and seat. If the pump has **metal** spring retainers in the outlet valves, position them so a leg does not point toward the center of the pump (refer to the illustration).

## 3. Inspect and Replace Diaphragms (22)

- Lift the diaphragm by one edge, and turn the pump shaft until the diaphragm pulls up. This will expose machined cross holes in the valve plunger shaft behind the diaphragm.
- Insert an Allen wrench through one of the holes, to hold the diaphragm up. The proper size tool is included in the Wanner Tool Kit.

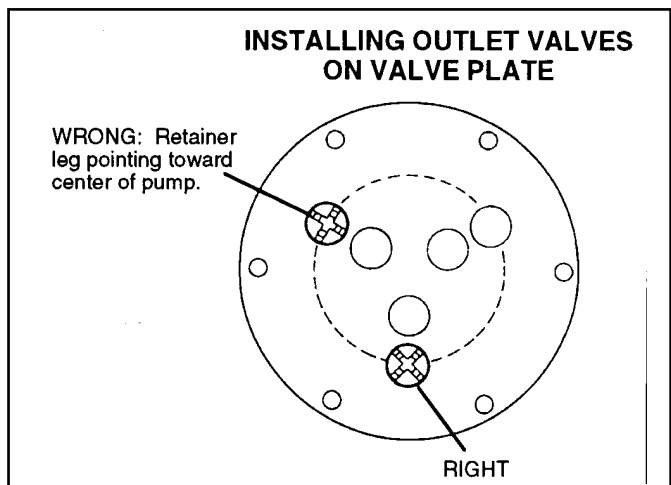

## H-25/G-25 Service (Fluid End) – Continued

- c. Remove the screw (19), O-ring (20), and follower (21) in the center of the diaphragm.
- d. Remove the diaphragm and inspect it carefully. A ruptured diaphragm generally indicates a pumping system problem, and replacing only the diaphragm will not solve the larger problem. Inspect the diaphragm for the following:
  - **Half-moon marks.** Usually caused by cavitation of the pump (refer to the “Troubleshooting” section).
  - **Concentric circular marks.** Usually caused by cavitation of the pump (refer to the “Troubleshooting” section).
  - **Small puncture.** Usually caused by a sharp foreign object in the fluid, or by an ice particle.
  - **Diaphragm pulled away** from the center screw or from the cylinder sides. Usually caused by fluid being frozen in the pump, or by overpressurization of the pump.
  - **Diaphragm becoming stiff** and losing flexibility. Usually caused by pumping a fluid that is incompatible with the diaphragm material.
  - diaphragm is operated at temperatures below its rated capability.
  - **Diaphragm edge chewed away.** Usually caused by overpressurizing the system.
- f. Inspect the plunger (23) for any rough surfaces or edges. Do not remove the plunger from the valve plunger (54). Smooth the surfaces and edges as necessary with emery cloth or a fine file.

**CAUTION: If a diaphragm has ruptured and foreign material or water has entered the oil reservoir, do not operate the pump. Check all diaphragms, then flush the reservoir completely (as outlined below) and refill it with fresh oil. Never let the pump stand with foreign material or water in the reservoir, or with the reservoir empty.**
- g. Install a new diaphragm (or reinstall the old one, as appropriate), ridge side out.
- h. Clean the screw (19) and remove any oil from it. Apply medium-strength threadlocker to the screw. Reinstall the screw, the follower (21), and a new O-ring (20). Tighten to 18 in.-lbs (2.0 N-m).
- i. Repeat the above inspection procedure (and replacement, if necessary) with the other two diaphragms.

### 4. Flush Contaminant from Hydraulic End (only if a diaphragm has ruptured)

- a. Remove the oil drain cap (34) and allow all oil and contaminant to drain out.
- b. Fill the reservoir with kerosene or solvent, manually turn the pump shaft to circulate the kerosene, and drain.

**CAUTION: If you have EPDM diaphragms, or if food grade oil is in the reservoir, do not use kerosene or solvents. Instead, flush with the same lubricant that is in the reservoir. Pumps with EPDM diaphragms have an “E” as the 7th digit of the Model No.**

- c. Repeat the flushing procedure (step b).
- d. Fill the reservoir with fresh oil, manually turn the pump shaft to circulate the oil, and drain once again.
- e. Refill the reservoir. If the oil appears milky, there is still contaminant in the reservoir. Repeat the flushing procedure until the oil appears clean.

### 5. Prime the Hydraulic Cells

- a. With the pump **horizontal and the fluid-end head removed**, fill the reservoir with the appropriate Hydra-Oil for the application.
- b. All air in the oil within the hydraulic cell (behind the diaphragms) must be forced out by turning the shaft (and thus pumping the piston). A shaft rotator is included in the Wanner Tool Kit. Turn the shaft until a **bubble-free** flow of oil comes from behind all the diaphragms. Watch the oil level in the reservoir; if it gets too low during priming, air will be drawn into the pistons (inside the hydraulic end) and will cause the pump to run rough.
- c. Wipe excess oil from the cylinder casting and diaphragms.

### 6. Reinstall Valve Plate (18), Manifold (7)

- a. Reinstall the valve plate (18), with the valve assemblies installed as outlined above, onto the cylinder casting.
- b. Reinstall the O-rings between the valve plate and manifold. (See illustrations to determine which O-rings to use depending on pumping head material.) Use petroleum jelly or lubricating gel to hold them in place.
- c. Reinstall the manifold onto the valve plate. Be sure the drain plug (4) is at the bottom of the manifold. If the pumping head is non-metallic, support plate (43) is also required.
- d. Insert all bolts (5), washers (6), and nuts (31) around the edge of the manifold, and the centerbolt (1) with washer (2). Hand tighten.
- e. **H-25 (external centerbolt models only).** Install the centerbolt (1), with its washer (2), and tighten it. Torque to 60 N-m.

#### Model H-25

- e. Torque centerbolt to 45 ft-lbs.
- f. Alternately tighten opposite bolts (5) until all are secure. Torque to 45 ft-lbs.

#### Model G-25

- e. Alternately tighten opposite bolts (5) until all are secure. Torque to 60 N-m.
- f. Torque the centerbolt to 60 N-m.

# H-25/G-25 Service (Fluid End) – Continued

## Model H-25, G-25 Valve Assemblies

Valve Assembly with metal spring retainer

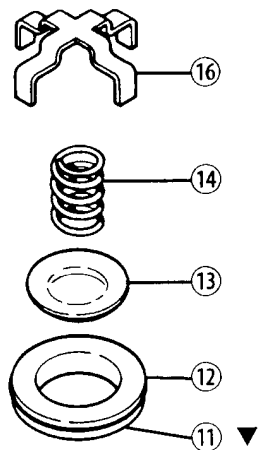

Valve Assembly with Celcon (plastic) spring retainer and dampening washer (38)

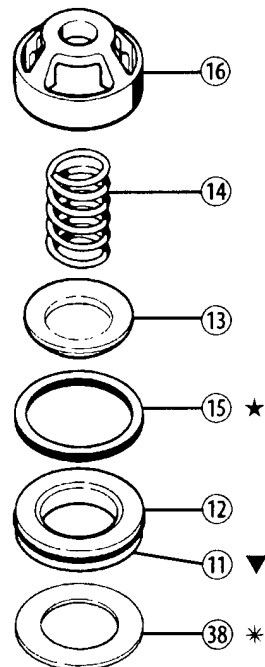

★ Tetra seal (15) is used only with plastic retainers.

▼ O-ring (11) is shown installed on valve seat (12).

\* Not required on all pumps.



# H-25/G-25 Service (Hydraulic End) – Continued

**NOTE:** The numbers in parentheses are the Ref. Nos. on the illustrations in the Parts Manual.

**CAUTION:** Do not disassemble the hydraulic end unless you are a skilled mechanic. For assistance, contact Wanner Engineering (TEL 612-332-5681 or FAX 612-332-6937) or the distributor in your area.

**CAUTION:** The four bolts (26) that screw through the back of the housing into the cylinder casting (25) hold the casting to the pump housing. Do not remove them except when repairing the hydraulic end.

**NOTE:** The following service procedures refer several times to the Wanner Tool Kit. We strongly urge you not to try to repair the hydraulic end of the pump without using the tools in this kit (available from Wanner or your local distributor).

## 1. Remove Pump Housing

- a. Remove the head of the pump, and the diaphragms, as outlined in the Fluid-End Service Section.
- b. Drain the oil from the pump housing by removing the drain plug (34).
- c. Set the hydraulic end of the pump face-down on the cylinder casting (25).
- d. Check the shaft for sharp burrs. Smooth any burrs, to prevent scarring the housing seals (64) when you disassemble the pump.
- e. Remove the bolts (26) that secure the housing to the cylinder casting. The piston return springs (50) will force the cylinder casting and housing apart.
- f. Lift off the housing (30).
- g. Inspect the cam and bearings (62), and the bearing race in the rear of the housing. If the bearings are pitted or binding, or if the housing race is worn, contact Wanner Engineering.

## 2. Disassemble Pistons

- a. With the pump housing removed (see above), turn the unit over and set it on a flat surface, piston side down.
- b. With diaphragms removed (see the Fluid-End Service Section), reinsert a follower screw (19) into the hole in one of the valve plungers (54). Tap the screw lightly with a hammer; the plunger (23) should slip off the valve plunger (54).  
The hydraulic piston assembly (50-59) can now be disassembled. Inspect all parts, and replace all O-rings and any other parts that are worn or damaged.
- c. Repeat step b for the remaining pistons.

**NOTE:** When you reassemble the hydraulic piston, use new plungers (23). They are press-fit onto the valve plungers (54) and are generally not reusable.

## 3. Reassemble Pistons

- a. Drop a ball (58) into each opening in the bottom of a piston assembly (59).
- b. Insert a retaining washer (57) and O-ring (56) to hold the ball in place.
- c. Insert a valve plunger (54) into a valve cylinder (55). Slide a spring (53) over the plunger, inside the valve cylinder.
- d. Insert an O-ring (52) into a spring retainer (51).
- e. Install two O-rings (52) on the valve cylinder (55).
- f. Slide the assembled valve cylinder, plunger, and spring (53-55) into the spring retainer (51).
- g. Install an O-ring (56) on the spring retainer (51).
- h. Slide the complete cylinder-and-retainer assembly (51-56) into the piston assembly (59).
- i. Insert a return spring (50) into the piston assembly.
- j. Repeat the above procedure for the other two pistons.

## 4. Reassemble Pump Housing and Cylinder Casting

**NOTE:** Inspect the shaft seals (64) before continuing. If they look damaged in any way, replace them (remove by pounding them out from inside the pump housing). Both seals should be replaced at the same time. Clean the seal bore in the housing, using emery cloth or ScotchBrite™.

- a. Place the cylinder casting (25) face-down on a flat surface.
- b. Insert the assembled pistons (50-59) into the cylinder casting.
- c. Note the location of the outer ring of holes in the cylinder casting and in the pump housing flange — in particular, the holes where bolts (26) will be installed. Screw threaded studs (from the Wanner Tool Kit) into two of the four threaded holes in the cylinder casting. Use opposite holes.
- d. Stand the camshaft assembly (62) on the cylinder casting (25).

**CAUTION:** The pilot bearing **MUST** be properly nested in the bearing race during assembly. If misaligned, the bearing will be damaged and the pump will fail within the first hours of operation.

- e. Using grease to retain it, install the O-ring (65) and slide the housing (30) down over the shaft and onto the threaded studs (from step c). Be sure the holes in the housing and the cylinder casting are properly aligned.
- f. Install washers (6) and nuts (31) on the threaded studs, but don't tighten yet. You may want to insert two or more bolts (5) into the unthreaded holes of the housing and cylinder casting to help align the parts.
- g. Alternately tighten the nuts (31) to evenly draw the

# H-25/G-25 Service (Hydraulic End) – Continued

housing down to the cylinder casting. Be sure the O-ring (65) stays in place.

Also, as you tighten the nuts keep checking the shaft alignment by turning the shaft (use the rotator in the Wanner Tool Kit). If the shaft begins to bind and become difficult to turn, back off the nuts and realign the shaft. When the pump housing is tight against the cylinder casting, you should be able to turn the shaft smoothly.

- h. After all the nuts (31) are tightened, insert cap screws (26), with washers (6), into the two unused threaded holes in the housing. Then remove the two threaded studs and replace them with the other two cap screws and washers.
- i. Turn the shaft again to check its alignment.

## 5. Replace Shaft Seals

- a. Apply a thin film of grease on the seal protector tool (part of the Wanner Tool Kit). Slide both seals onto the tool, with the spring side of the seals toward the open end of the tool.  
Apply a heavier coat of grease between the seals and press them together.
- b. Apply a coating of Loctite® High-Performance Pipe Sealant With Teflon, or a comparable product, to the outer surface of both seals and the inside surface of the opening in the pump housing where the seals will rest.
- c. Apply a light film of grease to the drive shaft. Slide the seal protector tool (with the two seals) over the end of the shaft.
- d. Slide the seal inserter tool (from the Wanner Tool Kit) over the seal protector tool, and press the seals completely into place. Tap the tool with a soft mallet to firmly seat the seals.

## 6. Adjust Camshaft Endplay

- a. If the three set screws (24) are in the cylinder casting (25), remove and clean them.
- b. Insert the centerbolt (1) into the hole in the center of the cylinder casting. Turn it in to move the bearing adjusting plate (61) and cup tight against the bearing cone.
- c. Back out the centerbolt **two** full turns, then turn it back in again until it is tight against the adjusting plate (61).
- d. Back out the centerbolt **exactly 1/4** of a turn.
- e. With a plastic mallet (or a regular mallet and wooden board) to prevent damage to the shaft, rap the end of the shaft three or four times. This will provide about 0.006 in. (0.15 mm) endplay in the shaft.
- f. Apply removable threadlocker to the threads of the three cleaned set screws (24).  
Screw the three set screws (24) into the cylinder casting until they contact the bearing adjusting plate (61).
- g. Remove the centerbolt (1).

## 7. Install Plungers

**NOTE: If the plungers (23) have been removed from the valve plungers (54), do not reuse them. Install new ones instead.**

- a. Rotate the pump shaft so the piston is in the top-dead-center position.
- b. Place a plunger on the exposed screw end of the plunger guide tool from the Wanner Tool Kit. The larger-diameter side of the plunger should face the tool.
- c. Screw the guide (with the plunger) into the valve plunger (54) until tight.
- d. Hold the single bottom handle of the guide, and turn the double top handle to force the plunger to seat on the valve plunger. This is a press-fit — when installed, the plunger should be tight against the shoulder of the valve plunger.

**NOTE: Do not remove the plunger guide until the diaphragm is installed (see below).**

- e. Install the diaphragm as outlined below, then repeat the procedure for the other two plungers and diaphragms.

## 8. Reinstall Diaphragms

- a. With the plunger guide tool still screwed into the valve plunger (54), pull the valve plunger up until the cross-holes in the valve plunger are exposed.
- b. Insert a diaphragm Allen wrench (from the Wanner Tool Kit), or a similar dowel-type object, through the holes — to hold the plunger (23) away from the cylinder casting, and to keep the valve plunger from turning when the diaphragm is being installed.
- c. Place the diaphragm (22) onto the plunger (23), ridge-side out.
- d. Center the diaphragm follower (21) on the diaphragm.
- e. Place the O-ring (20) onto the follower screw (19).
- f. Apply a small amount of threadlocker to the threads of the follower screw.
- g. Insert the follower screw (with O-ring) through the diaphragm follower (21) and diaphragm (22), and screw it into the valve plunger (54).
- h. Hold the diaphragm Allen wrench, and torque the follower screw to 18 in.-lbs (2.0 N-m).
- i. Repeat the above procedure for the plungers and diaphragms of the other two cylinders.
- j. Fill the reservoir with fresh oil and prime the pump, as outlined in the Fluid-End Service Section.

## 9. Reassemble Pump Head

Reassemble the pump head as outlined in the Fluid-End Service Section.

# H-25/G-25 Troubleshooting

---

## Cavitation

- Inadequate fluid supply because:
  - Inlet line collapsed or clogged
  - Clogged line strainer
  - Inlet line too small or too long
  - Air leak in inlet line
  - Worn or damaged inlet hose
  - Suction line too long
  - Too many valves and elbows in inlet line
- Fluid too hot for inlet suction piping system.
- Air entrained in fluid piping system.
- Aeration and turbulence in supply tank.
- Inlet vacuum too high

## Symptoms of Cavitation

- Excessive pump valve noise
- Premature failure of spring or retainer
- Volume or pressure drop
- Rough-running pump
- Premature failure of diaphragms
- Piston return spring failure (insed hydraulic end)

## Drop in Volume or Pressure

A drop in volume or pressure can be caused by one or more of the following:

- Air leak in suction piping
- Clogged suction line or suction strainer
- Suction line inlet above fluid level in tank
- Inadequate fluid supply
- Pump not operating at proper RPM
- Relief valve bypassing fluid
- Worn pump valve parts
- Foreign material in inlet or outlet valves
- Loss of oil prime in cells because of low oil level
- Ruptured diaphragm
- Cavitation
- Warped manifold from overpressurized system
- O-rings forced out of their grooves from overpressurization
- Air leak in suction line strainer or gasket
- Cracked suction hose.
- Empty supply tank
- Excessive aeration and turbulence in supply tank
- Worn and slipping drive belt(s)
- Worn spray nozzle(s)
- Cracked cylinder casting

## Pump Runs Rough

- Worn pump valves
- Airlock in outlet system
- Oil level low
- Wrong weight of oil for cold operating temperatures (change to lighter weight)
- Cavitation
- Air in suction line
- Restriction in inlet/suction line
- Hydraulic cells not primed after changing diaphragm
- Foreign material in inlet or outlet valve
- Damaged diaphragm
- Fatigued or broken valve spring
- Broken piston return spring (insed hydraulic end)

## Premature Failure of Diaphragm

- Frozen pump
- Puncture by a foreign object
- Elastomer incompatible with fluid being pumped
- Pump running too fast
- Excess pressure
- Cavitation
- Broken piston return spring (50)

## Water (or Process Fluid) in Oil Reservoir

- Condensation
- Ruptured diaphragm
- Hydraulic cell not properly primed after diaphragm replacement
- Frozen pump
- Diaphragm screw O-ring (18) missing or cracked
- Cracked cylinder casting

## Strong Water (or Process Fluid) Pulsations

**NOTE: Small pulsations are normal in single-acting pumps with multiple pumping chambers.**

- Foreign object lodged in pump valve
- Loss of prime in hydraulic cell because of low oil level
- Air in suction line
- Valve spring (13) broken
- Cavitation
- Aeration or turbulence in supply tank

## H-25/G-25 Troubleshooting – Continued

---

### Valve Wear

- Normal wear from high-speed operation
- Cavitation
- Abrasives in the fluid
- Valve incompatible with corrosives in the fluid
- Pump running too fast

### Loss of Oil

- External seepage
- Rupture of diaphragm
- Frozen pump
- Diaphragm screw O-ring (18) missing or cracked
- Worn shaft seal
- Oil drain piping or fill cap loose.
- Valve plate and manifold bolts loose

### Premature Failure of Valve Spring or Retainer

- Cavitation
- Foreign object in the pump
- Pump running too fast
- Spring/retainer material incompatible with fluid being pumped
- Excessive inlet pressure.

### **Limited Warranty**

Wanner Engineering, Inc. extends to the original purchaser of equipment manufactured by it and bearing its name, a limited one-year warranty from the date of purchase against defects in material or workmanship, provided that the equipment is installed and operated in accordance with the recommendations and instructions of Wanner Engineering, Inc. Wanner Engineering, Inc. will repair or replace, at its option, defective parts without charge if such parts are returned with transportation charges prepaid to Wanner Engineering, Inc., 1204 Chestnut Avenue, Minneapolis, Minnesota 55403.

This warranty does not cover:

1. The electric motors (if any), which are covered by the separate warranties of the manufacturers of these components.
2. Normal wear and/or damage caused by or related to abrasion, corrosion, abuse, negligence, accident, faulty installation or tampering in a manner which impairs normal operation.
3. Transportation costs.

This limited warranty is exclusive, and is in lieu of any other warranties (express or implied) including warranty of merchantability or warranty of fitness for a particular purpose and of any noncontractual liabilities including product liabilities based on negligence or strict liability. Every form of liability for direct, special, incidental or consequential damages or loss is expressly excluded and denied.



**WANNER ENGINEERING, INC.**

1204 Chestnut Avenue, Minneapolis, MN 55403  
TEL: (612) 332-5681 FAX: (612) 332-6937  
TOLL-FREE FAX [US only]: (800) 332-6812

www.hydra-cell.com  
email: sales@wannereng.com  
Document Fax Back System: (510) 745-0440

G25-991-2400 Rev. D

©2002 Wanner Engineering, Inc. Printed in USA 01/02