

INSTALLATION & SERVICE

Hydra-Cell[®] **INDUSTRIAL PUMPS**

H-25-SD, G-25-SD
SLURRY DUTY PUMPS

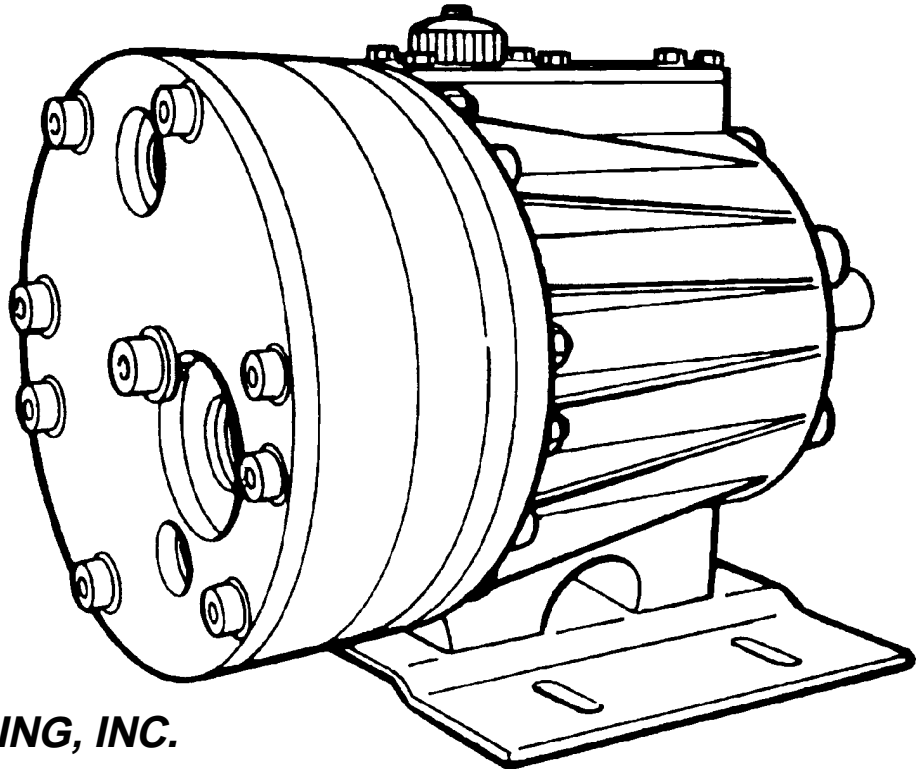

WANNER ENGINEERING, INC.

1204 Chestnut Avenue, Minneapolis, MN 55403
TEL: (612) 332-5681 FAX: (612) 332-6937
TOLL-FREE FAX [US only]: (800) 332-6812

H-25-SD WPR = 300 psi; G-25-SD WPR = 21 bar

www.hydra-cell.com
email: sales@wannereng.com
Document Fax Back System (510) 745-0440

H-25-SD/G-25-SD Contents

	Page
Installation	2
Maintenance	5
Service (Fluid End)	6
Service (Hydraulic End)	12
Troubleshooting	13

NOTE: The numbers in parentheses are the Reference Numbers on the illustrations in the Parts Manual.

H-25-SD/G-25-SD Installation

Location

Locate the pump as close to the supply source as possible.

Install it in a lighted clean space where it will be easy to inspect and maintain. Allow room for checking the oil level, changing the oil, and removing the manifold support (43), manifold (7), and valve plate (18).

Mounting

Do not exceed the maximum pump speed. Refer to the Pump Specifications Manual for ratings.

The pump shaft can rotate in either direction.

To prevent vibration, mount the pump securely on a level rigid base.

On a belt-drive system, align the sheaves accurately; poor alignment wastes horsepower and shortens the belt and bearing life. Make sure the belts are properly tightened, as specified by the belt manufacturer.

On a direct-drive system, align the shafts accurately to the specifications of the coupler manufacturer.

Important Precautions

Adequate Fluid Supply. To avoid cavitation and premature pump failure, be sure that the pump will have an adequate fluid supply and that the inlet line will not be obstructed. See "Inlet Piping".

Positive Displacement. This is a positive-displacement pump. To avoid severe system damage if the discharge line ever becomes blocked, install a relief valve downstream from the pump. See "Discharge Piping".

Safety Guards. Install adequate safety guards over all pulleys, belts, and couplings. Follow all codes and regulations regarding installation and operation of the pumping system.

Shut-Off Valves. Never install shut-off valves between the pump and discharge pressure regulator, or in the regulator bypass line.

Freezing Conditions. Protect the pump from freezing. See also the Maintenance Section.

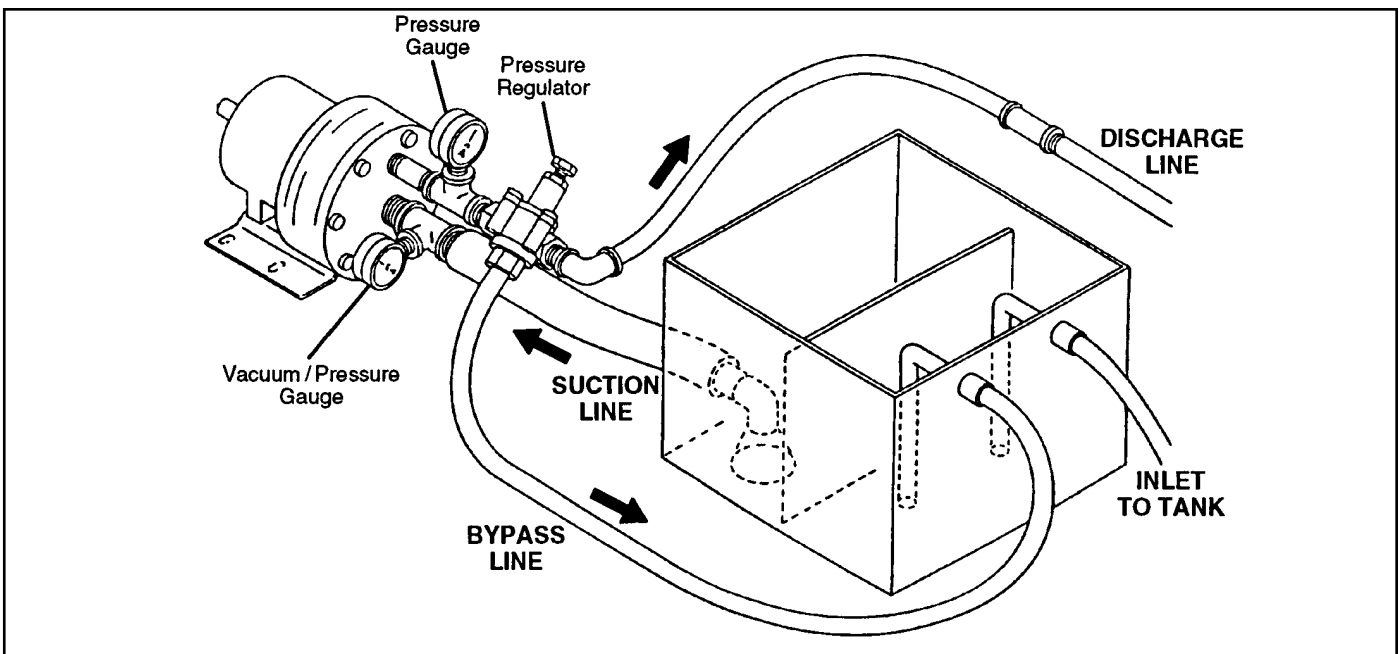

H-25-SD/G-25-SD Installation

Inlet Piping (Suction Feed)

Caution: Do not pump at fluid temperatures above 140° F (60° C). Consult the Pump Specifications Manual for current ratings, based on the pump head material.

Install draincocks at any low points of the suction line, to permit draining in freezing conditions.

Provide for permanent or temporary installation of a vacuum gauge to monitor the inlet suction. Vacuum at the pump inlet should not exceed **7 in. Hg**.

Do not supply more than one pump from the same inlet line.

Consult the Factory for the following situations:

- Extreme temperature applications — above 120° F (49° C) or below 40° F (4° C)
- Pressure feeding of pumps
- Viscous or extremely abrasive fluid applications
- Chemical compatibility problems
- Hot ambient temperatures — above 100° F (38° C)
- Conditions where pump oil may exceed 180° F (82° C) because of a combination of hot ambient temperatures, hot fluid temperature, and full horsepower load — an oil cooler may be required

Supply Tank

See the illustration on page 2.

Use a supply tank that is large enough to provide time for any trapped air in the fluid to escape. The tank size should be at least twice the maximum pump flow rate.

Isolate the pump and motor stand from the supply tank, and support them separately.

Install a separate inlet line from the supply tank to each pump.

Install the inlet and bypass lines so they empty into the supply tank below the lowest water level, on the opposite side of the baffle from the pump suction line.

If a line strainer is used in the system, install it in the inlet line to the supply tank.

To reduce aeration and turbulence, install a completely-submerged baffle plate to separate the incoming and outgoing liquids.

Install a vortex breaker in the supply tank, over the outlet port to the pump.

Place a cover over the supply tank, to prevent foreign objects from falling into it.

Hose Size and Routing

Size the suction line at least one size larger than the pump inlet, and so that the velocity will not exceed 1 to 3 ft/sec (0.3 to 0.9 m/sec):

$$\text{Velocity (ft/sec)} = \frac{0.408 \times \text{GPM}}{\text{Pipe I.D.}^2 *}$$

*where pipe I.D. is in inches

Keep the suction line as short and direct as possible.

The smallest permissible inlet hose size is:

1 to 10 gpm	1-1/2 in. I.D.
11 to 20 gpm	2 in. I.D.
1 to 38 liters/min	38 mm I.D.
39 to 76 liters/min	50 mm I.D.

Use flexible hose and/or expansion joints to absorb vibration, expansion, or contraction.

If possible, keep the suction line level. Do not have any high points to collect vapor unless these high points are vented.

To reduce turbulence and resistance, do not use 90° elbows. If turns are necessary in the suction line, use 45° elbows or arrange sweeping curves in the flexible inlet hose.

If a block valve is used, be sure it is fully opened so that the flow to the pump is not restricted. The opening should be at least the same diameter as the inlet plumbing I.D.

Do not use a line strainer or filter in the suction line unless regular maintenance is assured. If used, it should have a free-flow area of at least three times the free-flow area of the inlet.

Install piping supports where necessary to relieve strain on the inlet line and to minimize vibration. **These supports are essential because the manifold and inlet/outlet adapters are plastic and more susceptible to damage.**

Always tighten all piping connections, gauges, and regulators before installing the piping cluster into the pump manifold.

Inlet Piping (Pressure Feed)

Provide for permanent or temporary installation of a vacuum/pressure gauge to monitor the inlet vacuum or pressure. Pressure at the pump inlet should not exceed 50 psi (345 kPa); if it could get higher, install an inlet pressure regulator.

Do not supply more than one pump from the same inlet line.

Always tighten all piping connections, gauges, and regulators before installing the piping cluster into the pump manifold.

H-25-SD/G-25-SD Installation

Inlet Calculations

Acceleration Head

Calculating the Acceleration Head

Use the following formula to calculate acceleration head losses. Subtract this figure from the NPSHa, and compare the result to the NPSHr of the Hydra-Cell pump.

$$H_a = (L \times V \times N \times C) \div (K \times G)$$

where:

H_a = Acceleration head (ft of liquid)

L = Actual length of suction line (ft) — not equivalent length

V = Velocity of liquid in suction line (ft/sec) [$V = \text{GPM} \times (0.408 \div \text{pipe ID}^2)$]

N = RPM of crank shaft

C = Constant determined by type of pump — use 0.066 for the H-25-SD and G-25-SD Hydra-Cell pumps

K = Constant to compensate for compressibility of the fluid — use: 1.4 for de-aerated or hot water; 1.5 for most liquids; 2.5 for hydrocarbons with high compressibility

G = Gravitational constant (32.2 ft/sec²)

Friction Losses

Calculating Friction Losses in Suction Piping

When following the above recommendations (under “Inlet Piping”) for minimum hose/pipe I.D. and maximum length, frictional losses in the suction piping are negligible (i.e., $H_f = 0$) if you are pumping a water-like fluid.

When pumping more viscous fluids such as lubricating oils, sealants, adhesives, syrups, varnishes, etc., frictional losses in the suction piping may become significant. As H_f increases, the available NPSH (NPSHa) will decrease, and cavitation will occur.

In general, frictional losses increase with increasing viscosity, increasing suction-line length, increasing pump flowrate, and decreasing suction-line diameter. Changes in suction-line diameter have the greatest impact on frictional losses; a 25% increase in suction-line diameter cuts losses by more than two times, and a 50% increase cuts losses by a factor of five times.

Use one of the following formulas to calculate friction losses in your system. Subtract the resulting figure from the NPSHa, and compare the result to the NPSHr of the Hydra-Cell pump.

For flowrates of 1 to 10 gpm, use:

$$H_f = 0.38 \text{ ft} \times \frac{\text{CPS}}{100} \times \frac{\text{GPM}}{10} \times \frac{L}{3} \times \left(\frac{1.5}{\text{ID}}\right)^4$$

For flowrates of 11 to 20 gpm, use:

$$H_f = 0.25 \text{ ft} \times \frac{\text{CPS}}{100} \times \frac{\text{GPM}}{20} \times \frac{L}{3} \times \left(\frac{2}{\text{ID}}\right)^4$$

where:

CPS = Viscosity of pumped material (in centipoise)

L = Length of suction line (in feet), and

ID = Pipe I.D. (in inches)

Minimizing Acceleration Head and Frictional Losses

To minimize the acceleration head and frictional losses:

- Keep inlet lines less than 3 ft (1 m) long
- Use at least 1-1/2 in. (38 mm) I.D. inlet hose
- Use soft hose (low-pressure hose, noncollapsing) for the inlet lines
- Minimize fittings (elbows, valves, tees, etc.)
- **Use a suction stabilizer on the inlet.**

Net Positive Suction Head

NPSHa must be equal to or greater than NPSHr. If not, the pressure in the pump inlet will be lower than the vapor pressure of the fluid— and cavitation will occur.

Calculating the NPSHa

Use the following formula to calculate the NPSHa:

$$\text{NPSHa} = P_t + H_z - H_f - H_a - P_{vp}$$

where:

P_t = Atmospheric pressure

H_z = Vertical distance from surface liquid to pump centerline (if liquid is below pump centerline, the H_z is negative)

H_f = Friction losses in suction piping

H_a = Acceleration head at pump suction

P_{vp} = Absolute vapor pressure of liquid at pumping temperature

NOTES:

- In good practice, NPSHa should be 2 ft greater than NPSHr
- All values must be expressed in feet of liquid

Atmospheric Pressure at Various Altitudes

Altitude (ft)	Pressure (ft of H ₂ O)	Altitude (ft)	Pressure (ft of H ₂ O)
0	33.9	1500	32.1
500	33.3	2000	31.5
1000	32.8	5000	28.2

Discharge Piping

NOTE: Consult the Factory before manifolding two or more pumps together.

Hose and Routing

Size the discharge line one or two sizes larger than the pump discharge opening. Use the shortest, most direct route.

Size the discharge line so that the velocity will not exceed 7 - 10 ft/sec (2 to 3 m/sec):

$$\text{Velocity (ft/sec)} = \frac{0.408 \times \text{GPM}}{\text{Pipe I.D.}^{2*}}$$

*where pipe I.D. is in inches

H-25-SD/G-25-SD Installation

The smallest permissible discharge hose size is:

1 to 10 gpm	11/16 (0.687) in. I.D.
11 to 20 gpm	1 in. I.D.
1 to 38 liters/min	17 mm I.D.
39 to 76 liters/min	25 mm I.D.

Use flexible hose between the pump and hard piping, to absorb vibration, expansion, or contraction.

Never install a shutoff valve in the discharge line between the pump and the regulator, or in the bypass line.

Select pipe or hose with a working pressure rating of at least 1.5 times the maximum system pressure. Example: Select a 300-psi W.P.-rated hose for systems to be operated at 200-psi-gauge pressure.

Support the pump and piping independently. **These supports are essential, because the manifold and inlet/outlet adapters are plastic and more susceptible to damage.**

Pressure Regulation

Install a pressure regulator or unloader in the discharge line. Bypass pressure must not exceed the pressure limit of the pump.

Size the regulator so that, when fully open, it will be large enough to relieve the full capacity of the pump without overpressurizing the system.

Locate the valve as close to the pump as possible and ahead of any other valves.

Adjust the pressure regulating valve to no more than 10% over the maximum working pressure of the system. Do not exceed the manufacturer's pressure rating for the pump or regulator.

Route the bypass line to the supply tank, or to the suction line as far as possible from the pump (to reduce the chance of turbulence).

If the pump will be operating for a long time with the discharge closed and fluid bypassing, install a thermal protector set to trip at 120° F (49° C) in the bypass line — to prevent severe temperature buildup in the bypassed fluid.

Caution: Never install shutoff valves in the bypass line or between the pump and pressure regulator or relief valve.

Provide for permanent or temporary installation of a pressure gauge to monitor the discharge pressure at the pump.

For additional system protection, install a "pop-off" safety relief valve in the discharge line, downstream from the pressure regulator.

Always tighten all piping connections, gauges, and regulators before installing the piping cluster into the pump manifold.

Before Initial Start-Up

Before you start the pump, be sure that:

- All shut-off valves are open, and the pump has an adequate supply of fluid.
- All connections are tight.
- The oil level is approximately 1 in. (2.5 cm) from the top of the fill port — so that the floor of the upper reservoir within the pump housing is flooded and the chamber itself is about 1/4 full, allowing for oil expansion as the pump runs and heats up.
- The relief valve on the outlet of the pump is adjusted so the pump starts under minimum pressure.
- All pulleys and belts are properly aligned, and belts are tensioned according to specification.
- All pulleys and belts have adequate safety guards.

Initial Start-Up Procedure

1. Turn on power to the pump motor.
2. Check the inlet pressure or vacuum. Inlet vacuum must not exceed 7 in. Hg at 70° F (180 mm Hg at 21° C). Inlet pressure must not exceed 50 psi (345 kPa).
3. If you hear any erratic noise or if the flow is unsteady, refer to the Troubleshooting Section.
4. If the system has an air lock and the pump fails to prime:
 - a. Turn off the power.
 - b. Remove the drain plug (4) on the bottom center of the manifold.

Note: Fluid may come out of this port when the plug is removed. Provide an adequate catch basin for fluid spillage, if required. Fluid will come out of this port when the pump is started, so we recommend that you attach adequate plumbing from this port so fluid will not be sprayed or lost. Use high-pressure-rated hose and fittings from this port. Take all safety precautions to assure safe handling of the fluid being pumped.

 - c. Jog the system on and off until the fluid coming from this port is air-free.
 - d. Turn off the power.
 - e. Remove the plumbing that was temporarily installed, and reinstall the drain plug (4).
5. Adjust the discharge pressure regulator to the desired operating and bypass pressures.
6. After the pressure regulator is adjusted, set the "pop-off" safety relief valve at 100 psi (690 kPa) higher than the desired operating pressure. To verify this setting, adjust the discharge pressure regulator upward until the relief valve opens. Follow the recommendations in the above Note (Step 4b) for handling the fluid that will come from the relief valve.
7. Reset the discharge pressure regulator to the desired system pressure.
8. Provide a return line from the relief valve to the supply tank, similar to the bypass line from the pressure regulator.

H-25-SD/G-25-SD Maintenance

NOTE: The numbers in parentheses are the Ref. Nos. on the illustrations in the Parts Manual.

Daily

Check the oil level and the condition of the oil. The oil level should be 1 in. (2.5 cm) from the top of the fill port — so that the floor of the upper reservoir within the pump housing is flooded and the chamber itself is about 1/4 full, allowing for oil expansion as the pump runs and heats up.

Use the appropriate Wanner Hydra-Oil brand motor oil for the application — contact Wanner Engineering if in doubt.

Caution: If you are losing oil but don't see any external leakage, or if the oil becomes discolored and contaminated, one of the diaphragms (21) may be damaged. Refer to the Service Section. Do not operate the pump with a damaged diaphragm.

Caution: Do not leave contaminated oil in the pump housing or leave the housing empty. Remove contaminated oil as soon as discovered, and replace it with clean oil.

Periodically

Change the oil after the first 100 hours of operation, and every 1000 operating hours thereafter. When changing, remove the drain plug (36) at the bottom of the pump so all oil and accumulated sediment will drain out.

Caution: Do not turn the drive shaft while the oil reservoir is empty.

Check the inlet pressure or vacuum periodically with a gauge. If vacuum at the pump inlet exceeds 7 in. Hg (180 mm Hg), check the inlet piping system for blockages. If the pump inlet is located above the supply tank, check the fluid supply level and replenish if too low.

Caution: Protect the pump from freezing. Refer also to the "Shutdown Procedure".

Shutdown Procedure During Freezing Temperatures

1. Disconnect the inlet and outlet piping from the pump.
2. Remove the drain plug (1) at the bottom center of the manifold.
3. Open any draincocks in the piping.
4. Start the pump, and allow it to run until all fluid is removed from the pump head.
5. Stop the pump, and reinstall the drain plug.
6. Fill the pump with antifreeze.

When you put the pump back into service, thoroughly flush the antifreeze.

H-25-SD/G-25-SD Service (Fluid End)

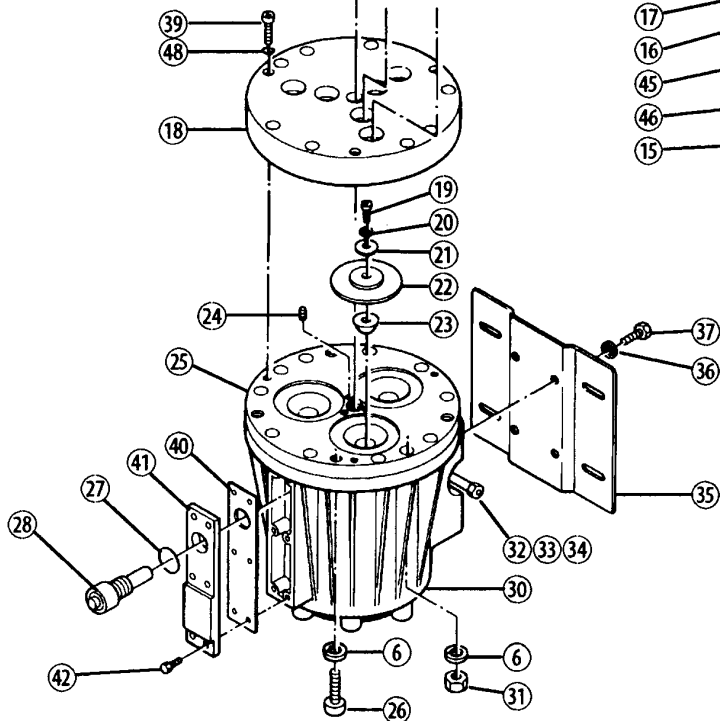
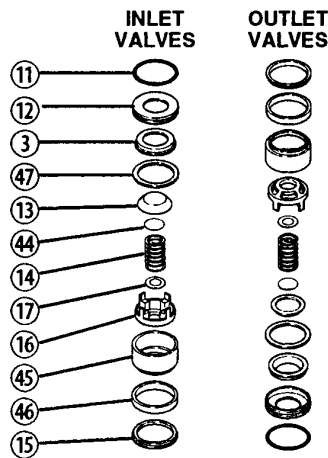
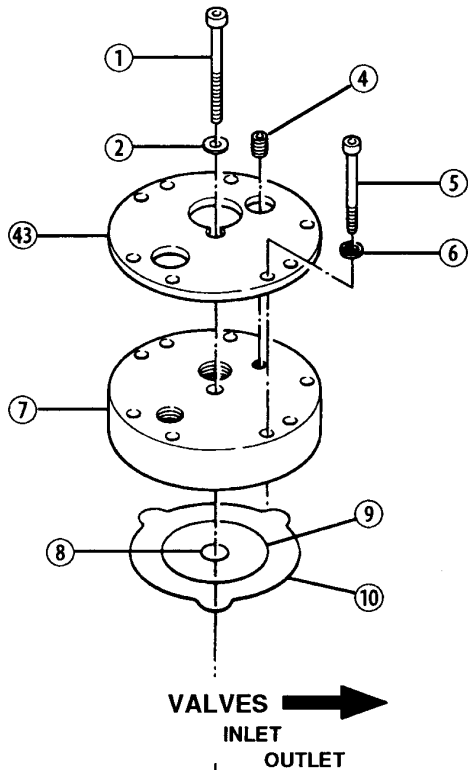

Note: The numbers in parentheses are the Ref. Nos. on the illustrations in the Parts Manual.

This section explains how to disassemble and inspect all easily-serviceable parts of the pump. Repair procedures for the hydraulic end (oil reservoir) of the pump are included in a later section of the manual.

Caution: Do not disassemble the hydraulic end unless you are a skilled mechanic. For assistance, contact Wanner Engineering (Tel 612-332-5681 or Fax 612-332-6937) or the distributor in your area.

Caution: The four capscrews (26) that screw through the back of the housing into the cylinder casting hold the casting over the hydraulic end of the pump. Do not remove them except when repairing the hydraulic end.

Tools and Supplies

The following tools and supplies are recommended for servicing the fluid end of the pump:

- Wanner G-25 Tool Kit (includes 8-mm and 10-mm hex bit sockets)
- 1/2-in. drive socket wrench
- 16-mm box-end wrench
- Straightedge (at least 10 in. long)
- Two 2-in. high blocks, approximately 2 to 3 in. wide and 6 to 8 in. long
- Medium Phillips-head screwdriver
- Mallet
- Small torque wrench — rated to at least 27 in.-lbs (3 N-m)
- Torque wrench — rated to at least 50 ft-lbs (68 N-m)
- New oil
- Grease or petroleum jelly
- Water or compatible solvent for cleaning

The following additional supplies are recommended for servicing the hydraulic end of the pump:

- 17-mm hex socket or box-end wrench
- 3/4-in. (19-mm) open-end or adjustable wrench
- 1-in. (26-mm) open-end or adjustable wrench
- Emery cloth or ScotchBrite™ pad
- Grease
- Anaerobic seal sealant

H-25-SD/G-25-SD Service (Fluid End)

Service Procedure

1. Remove Manifold Support (43), Manifold (7), and Valve Plate (18)

- a. With an 8-mm (or 5/16-in.) hex Allen wrench, and a 16-mm box-end wrench, remove all nuts (31) and capscrews (5) around the manifold support plate. Do not remove the four capscrews (26) that are installed through the back of the pump housing.
- b. With a 10-mm hex Allen wrench, remove the centerbolt (1) and its washer (2) in the center of the manifold support plate.

Caution: Do not turn the pump drive shaft while the manifold and valve plate are off the pump, except when removing diaphragms or repriming the hydraulic cells.

- c. Remove the manifold support (43) and manifold (7).
- d. Inspect the manifold support and manifold for warpage or wear around the inlet and outlet ports. Also inspect the manifold for warpage or wear in the area of the flow channels, especially where the valve assemblies contact the manifold. If wear is excessive, replace the manifold with a new one.

To check the manifold support for warpage, lay it on a flat surface and place a straightedge across it. Check both sides of the plate for warpage.

To check the manifold for warpage, first be sure any plugs or O-rings are removed, then lay it on a flat surface with the flow channels facing you. Place a straightedge across the raised surfaces of the manifold.

Note: A machined recess was cut around the perimeter of the manifold at the factory. Do not mistake this feature for warpage.

A warped manifold support or manifold should be replaced.

- e. With a 5-mm hex Allen wrench (included in the Wanner Tool Kit), remove the three socket-head capscrews (39) that hold the valve plate to the cylinder casting.

Note: There is an O-ring (48) under the head of each capscrew, which acts as a washer between it and the plastic valve plate.

2. Remove and Inspect Valve Assemblies (3, 11-17, 44-47)

Note: Wanner Repair Kits contain some or all of the required components to replace items (3), (11-17), and (44-47), as well as all O-rings for sealing the manifold to the valve plate. Consult the appropriate Parts Manual for your pump to determine which Repair Kit to order.

Remove the Valve Assemblies

The three inlet and three outlet valve assemblies in the pump are identical (but face in opposite directions). One at a time, remove each valve assembly with the aid of the valve seat remover tool (from the Wanner Tool Kit), then inspect and reinstall the valve assembly as outlined below. Be careful not to bend or break any of the metal valve components, and not to gouge or scrape the plastic valve plate.

Set the valve plate on 2-in. high blocks, with the valve assemblies facing down. As you press out each valve assembly during the following procedure, be sure there is enough open space below so that the valve can come out of its bore unobstructed.

To remove each valve assembly:

- a. **Inlet (3 center valves).** From the large hole at the bottom of the diaphragm pocket in the valve plate, press down on the spring retainer (16) until the valve seat, valve, and spring fall out of the bore. You may have to use a mallet along with the valve seat remover tool. Next, work the valve seat remover tool between the

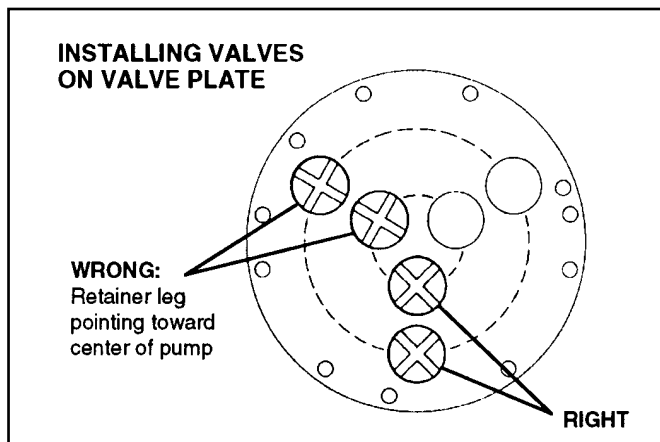

spacer (15) and the shoulder of the valve plate bore, again through the large hole at the bottom of the diaphragm pocket.

Press and tap down as required, working your way around the edge of the spacer to force the shell subassembly, crush seal, and spacer evenly out of the valve bore.

- b. **Outlet (3 outer valves).** From the small hole at the bottom of the diaphragm pocket in the valve plate, and through the valve seat bore, press down evenly on the valve (13) until it stops against the spring retainer.

Note: The valve seat remover tool must be tipped approximately 45° to get it through the seat bore.

Continue pressing or tapping, as required, until the spacer, crush seal, shell subassembly, spring, and valve fall out of the valve bore.

Next, work the valve seat remover tool between the seat holder (12) and the shoulder of the valve plate bore, again through the small hole at the bottom of the diaphragm pocket.

Press and tap down as required, working your way around the edge of the seat holder to force the spacer and seat subassembly evenly out of the valve bore.

H-25-SD/G-25-SD Service (Fluid End)

- c. Inspect both sides of the valve plate for wear, including the diaphragm pockets, valve bores, and shoulders at the bottom of each bore. Also inspect the face of the valve plate (adjacent to the valve bores) for wear, especially in the areas where the O-rings seal between it and the manifold. Using a straightedge, inspect both sides of the valve plate for warpage. If there is warpage or excessive wear, replace the valve plate.

Inspect the Valve Components

Inspect the individual components of each valve as follows:

- a. Check the spring retainer (16) that is housed inside the shell (45). Be sure to locate the polyurethane washer (17) that sits in the spring retainer recess and supports the spring (14). If the spring retainer is worn in the area of the four tabs that guide and act as a stop for the valve, replace it.

Also look for wear in the area of the recess that supports the spring. The polyurethane washer should have minimized or prevented wear in this area if it stayed in place during operation.

Press out the old spring retainer and push in a new one if required. It is always a good idea to use a new polyurethane washer in the spring retainer recess. Be careful to put only one washer into each retainer recess.

- b. Check the valve spring (14) for wear or damage. Compare its free length to that of a new spring. A worn or otherwise damaged spring should be replaced with a new one. Never attempt to stretch an old spring and reuse it.
- c. Check the valve (13) for uneven or excessive wear. If it has developed an uneven wear pattern or is worn excessively, do not reuse it — replace it with a new one. A valve with an uneven wear pattern will not seal effectively, even against a new seat, resulting in rough operation and reduced output.

Note: Your pump has a urethane washer (44) in the recess on the back side of each valve. It is there to reduce or eliminate wear on the valve caused by motion between the spring and valve. It also helps minimize wear on the end of the spring. It is always a good idea to replace these washers with new ones. Be careful to put only one washer into each valve recess.

- d. Remove the valve seat (3) from its holder (12). Inspect both parts for wear and replace either or both as necessary. It is always a good idea to use a new valve seat and O-ring (11) in the valve seat holder.

Note: Whenever you replace a worn valve, valve seat, or valve spring in any valve assembly, we recommend that you replace them in all valve assemblies at that time, to ensure the most reliable operation when you restart the pump. We also recommend that you always replace the washers and seals in the valve assemblies at that time, for the most reliable operation. All the necessary parts are included in a replacement valve kit and in a complete fluid-end kit.

Reinstall the Valve Assemblies

- a. Clean the valve ports and shoulders in the valve plate (18) with water or a compatible solvent. A ScotchBrite™ pad or brush may be used to abrade any old buildup or residue, but be careful not to scratch the plastic or wear away any of the plastic valve plate material. Rinse the valve plate after cleaning and lubricate the valve ports with a compatible grease, oil, or lubricating gel such as petroleum jelly.

Caution: If the elastomers are made of EPDM, do not use a petroleum-based lubricant on them. Instead, use an EPDM-compatible lubricant. If the product is food-grade, use a compatible food-grade lubricant.

- b. Install new O-rings (11) and seats (3) into each valve seat holder (12). Lubricate the O-rings.
- c. Install new polyurethane washers (17, 44) into each spring retainer recess and each valve recess, respectively. Install the spring retainers (16) into their shells (45) before installing the polyurethane washers in the retainers.

A small amount of grease or petroleum jelly should be used to help the washers stay in place during the rest of the assembly procedure. It is very important that these washers stay in their proper place until assembly is completed. If they do not, they could end up holding a valve open or clogging a valve or filter downstream of the pump. In addition, they will not do their job of minimizing wear of the spring retainers, springs, and valves if they are not properly in place.

- d. Install a new crush seal (46) on three of the shell subassemblies just completed above, for use in the outlet valves. Press the spacers (15) onto the crush seals to create a five-piece subassembly for each outlet valve. It is important to use new crush seals during each rebuilding, because they hold the spacers to the shells during subsequent assembly procedures. Using new crush seals also ensures proper compression on the valve assemblies when the manifold is clamped to the valve plate.

Consult the illustration on page 8 for proper orientation of the spring retainer tabs for both the inlet and outlet valves.

- e. **Inlet (3 center valves).** Insert the three remaining spacers (15) into the inner ring of valve bores in the valve plate. The flat, flanged end must be facing down toward the shoulder of the valve plate.

Note: You may have to press the spacers slightly, as there is a line-to-line fit between the outer diameter of the spacer and the valve bore.

Next, insert the remaining crush seals (46) onto the nose of the inlet valve spacers. **The seals *must* fit around the nose of the spacers.**

Insert the three-piece shell subassemblies (45, 16, 17) into the inlet valve bores. They too may have to be pressed slightly, as there is a line-to-line fit between the outer diameter of the shell and the valve bore. Be sure the nose of the shell (45) presses into the inner diameter of the crush seal (46). The shaft rotator (from the Wanner Tool Kit) can be used to press down evenly on the shell

H-25-SD/G-25-SD Service (Fluid End)

subassembly to get the proper fit.

Before continuing, check that each polyurethane washer is in its proper place, nested down into the recess of each spring retainer.

Insert the spacers (47) into the valve bores so that they rest on top of the shell subassemblies. Insert the springs (14) and valves (13), ensuring that each valve has a polyurethane washer (44) pressed into its recess — to minimize wear on the valve and the end of the spring.

Finally, press the valve seat subassemblies (3, 12, 11) down into the valve bores, compressing the valve spring slightly. The valve seat O-ring should be lubricated with grease or petroleum jelly to ease assembly. There is substantial interference between the O-ring and valve bore, so be careful not to shear the O-ring by driving it in too quickly. Use the seal inserter (from the Wanner Tool Kit) to push evenly on the seat, rocking very slightly, if required, to ease the O-ring into the bore. Push down on the valve until it hits the stops on the spring retainer, then let it pop back up to the seat to ensure proper operation.

- f. **Outlet (3 outer valves).** Press the three remaining valve seat subassemblies (11, 3, 12) into the outer ring of valve bores in the valve plate. The flat, metal end of the valve seat holder (12) must be facing down toward the shoulder of the valve plate. The valve bore and O-ring should be lubricated with grease or petroleum jelly to ease assembly. There is substantial interference between the O-ring and valve bore, so be careful not to shear the O-ring by driving it in too quickly.

Use the seal inserter to push the seat into the valve bore until it is flush with the plate, then use the shaft rotator and push down on the seats until they hit the shoulder at the bottom of each bore.

Insert the spacers (47) into the valve bores so they rest on top of the valve seats. Place the valves (13) and springs (14) onto the seats, ensuring that each valve has a polyurethane washer (44) pressed into its recess. Finally, insert the five-piece shell subassemblies into the bores, after checking that each polyurethane washer is in its proper place, nested down in the recess of each spring retainer. You may have to press slightly, as there is a line-to-line fit between the outer diameter of the shell and the valve bore.

From the other side of the valve plate (through the diaphragm pocket), push on the valve until it hits the stops on the spring retainer, then let it pop back to the seat to ensure proper operation. You may have to lightly hold the shell subassembly in place when doing this.

3. Inspect and Replace Diaphragms (22)

- a. Lift one of the diaphragms by one edge, and turn the pump shaft until the diaphragm pulls up. This will expose machined cross-holes in the valve plunger shaft behind the diaphragm.
- b. Insert an Allen wrench through one of the holes, to hold the diaphragm up. The proper size tool is included in the Wanner Tool Kit.
- c. Remove the screw (19), O-ring (20), and follower (21) in the center of the diaphragm.
- d. Remove the diaphragm and inspect it carefully. A ruptured diaphragm generally indicates a pumping system problem, and replacing only the diaphragm will not solve the larger problem. Inspect the diaphragm for the following:
 - **Half-moon marks.** Usually caused by cavitation of the pump (refer to “Troubleshooting”).
 - **Concentric circular marks.** Usually caused by cavitation of the pump (refer to “Troubleshooting”).
 - **Small puncture.** Usually caused by a sharp foreign object in the fluid, or by an ice particle.
 - **Diaphragm pulled away** from the center screw or from the cylinder sides. Usually caused by fluid being frozen in the pump, or by overpressurization of the pump.
 - **Diaphragm becoming stiff** and losing flexibility. Usually caused by pumping a fluid that is incompatible with the diaphragm material.
 - **Slice in ridge of diaphragm.** Occurs when a diaphragm is operated at temperatures below its rated capability.
 - **Diaphragm edge chewed away.** Usually caused by overpressurizing the system.
- e. Inspect the plunger (23) for any rough surfaces or edges. **Do not** remove the plunger from the valve plunger (54). Smooth the surfaces and edges as necessary with emery cloth or a fine file.

Caution: If a diaphragm has ruptured and foreign material or water has entered the oil reservoir, do not operate the pump. Check all diaphragms, then flush the reservoir completely (as outlined below) and refill it with fresh oil. Never let the pump stand with foreign material or water in the reservoir, or with the reservoir empty.
- f. Install a new diaphragm (or reinstall the old one, as appropriate), ridge side out.
- g. Clean and dry the screw (19), removing any oil from it. Apply medium-strength threadlocker to the screw. Reinstall the screw, the follower (21), and a new O-ring (20). Tighten to 18 in.-lbs (2.0 N-m).
- h. Repeat the above inspection procedure (and replacement, if necessary) with the other two diaphragms.

H-25-SD/G-25-SD Service (Fluid End)

4. Flush Contaminant from Hydraulic End (only if a diaphragm has ruptured)

- Remove the oil drain cap (34) and allow all oil and contaminant to drain out.
- Fill the reservoir with kerosene or solvent, manually turn the pump shaft to circulate the kerosene, and drain.
Caution: If you have EPDM diaphragms, or if food grade oil is in the reservoir, do not use kerosene or solvents. Instead, flush with the same lubricant that is in the reservoir. Pumps with EPDM diaphragms have an "E" as the 7th digit of the Model No.
- Repeat the flushing procedure (step b).
- Fill the reservoir with fresh oil, manually turn the pump shaft to circulate the oil, and drain once again.
- Refill the reservoir. If the oil appears milky, there is still contaminant in the reservoir. Repeat the flushing procedure until the oil appears clean.

5. Prime the Hydraulic Cells

- With the pump **horizontal and the fluid-end head removed**, fill the reservoir with the appropriate Hydra-Oil for the application.
- All air in the oil within the hydraulic cell (behind the diaphragms) must be forced out by turning the shaft (and thus pumping the piston). A shaft rotator is included in the Wanner Tool Kit. Turn the shaft until a **bubble-free** flow of oil comes from behind all the diaphragms. Watch the oil level in the reservoir; if it gets too low during priming, air will be drawn into the pistons (inside the hydraulic end) and will cause the pump to run rough.
- Wipe excess oil from the cylinder casting and diaphragms.

6. Reinstall Valve Plate (18), Manifold (7), and Manifold Support (43)

- Reinstall the valve plate (18), with the valve assemblies installed as outlined above, onto the cylinder casting. Use the three socket-head capscrews (39) with O-rings (48) to fasten the valve plate to the cylinder casting. Verify that the valve assemblies are still in place.
- Reinstall the O-rings (8, 9, 10) between the valve plate and manifold. Use petroleum jelly or lubricating gel to hold them in place.
- With the manifold support and manifold nested together, and the centerbolt (1) and washer (2) in place through the center hole, locate the drain plug (4) at the bottom and hold the manifold and support against the valve plate. Tighten the centerbolt by hand.

- Insert all bolts (5), washers (6), and nuts (31) loosely. Align the outer surfaces of the valve plate, manifold, and manifold support, and torque the centerbolt to 45 ft-lbs (60 N-m).
- Alternately tighten opposite bolts (5) until all are secured. Torque to 45 ft-lbs (60 N-m).

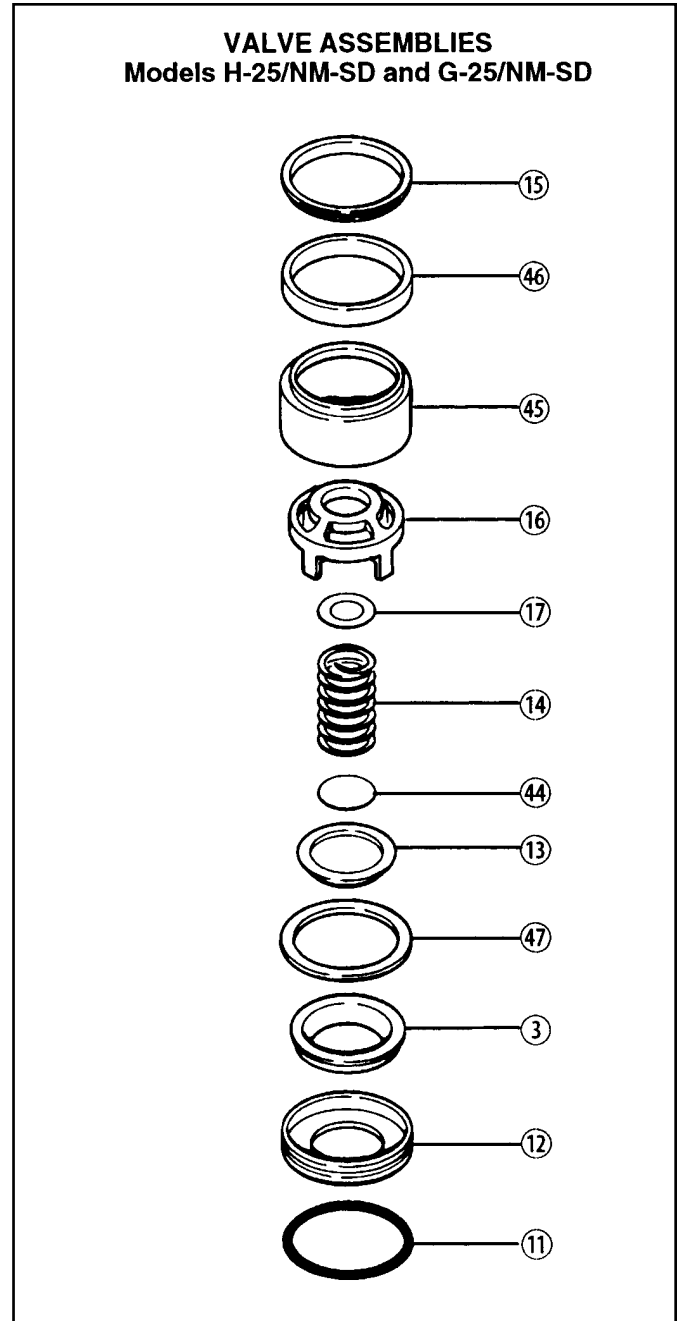

H-25-SD/G-25-SD Service (Hydraulic End)

Tools and Supplies

The following additional supplies are recommended for servicing the hydraulic end of the pump:

- 17 mm hex socket or box-end wrench
- 3/4 in. (19 mm) open-end or adjustable wrench
- 1 in (26 mm) open-end or adjustable wrench
- Emery cloth or ScotchBrite™ pad
- Grease
- Anaerobic seal sealant

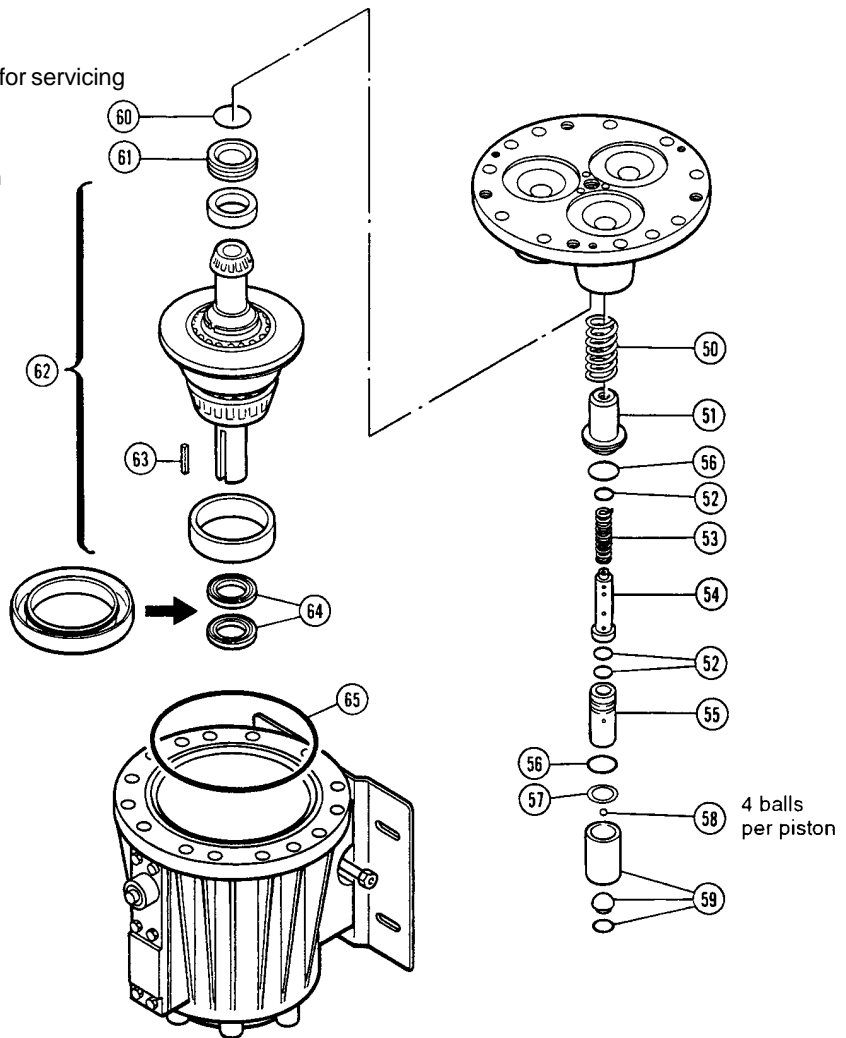

Note: The numbers in parentheses are the Ref. Nos. on the illustrations in the Parts Manual.

Caution: Do not disassemble the hydraulic end unless you are a skilled mechanic. For assistance, contact Wanner Engineering (Tel 612-332-5681 or Fax 612-332-6937) or the distributor in your area.

Caution: The four capscrews (26) that screw through the back of the housing into the cylinder casting (25) hold the casting to the pump housing. Do not remove them except when repairing the hydraulic end.

Note: The following service procedures refer several times to the Wanner Tool Kit. Do not try to repair the hydraulic end of the pump without using the tools in this kit (available from Wanner or your local distributor).

1. Remove Pump Housing

- Remove the head of the pump, and the diaphragms, as outlined in the Fluid End Service Section.
- Drain the oil from the pump housing by removing the drain plug (34). Dispose of the oil properly.
- Set the hydraulic end of the pump face-down on the cylinder casting (25).
- Check the shaft for sharp burrs. Smooth any burrs, to prevent scarring the housing seals (64) when you disassemble the pump.
- Alternately loosen the four capscrews (26) that secure the housing to the cylinder casting. The piston return springs (50) will force the cylinder casting and housing apart. Loosen each screw one to two turns before going to the next one, continuing until all four screws are removed.
- Lift off the housing (30).
- Inspect the cam and bearings (62), and the bearing race in the rear of the housing. If the bearings are pitted or binding, or if the housing race is worn, contact Wanner Engineering.

H-25-SD/G-25-SD Service (Hydraulic End)

2. Disassemble Pistons

- a. With the pump housing removed (see above), turn the cylinder casting over and set it on a flat surface, piston side down.
- b. With the diaphragms removed (see the Fluid End Service Section), reinsert a follower screw (19) into the hole in one of the valve plungers (54). Tap the screw lightly with a hammer; the plunger (23) should slip off the valve plunger (54).
- c. Repeat step “b” for the remaining pistons.
- d. Each hydraulic piston assembly (50-59) can now be disassembled. Lift the cylinder casting straight up and off the pistons. Inspect all parts, and replace all O-rings and any other parts that are worn or damaged.

Note: When you reassemble the hydraulic piston, use new plungers (23). They are press-fit onto the valve plungers (54) and are generally not reusable.

3. Reassemble Pistons

- a. Drop a ball (58) into each opening in the bottom of a piston assembly (59).
- b. Insert a retaining washer (57) and O-ring (56) to hold the ball in place.
- c. Insert a valve plunger (54) into a valve cylinder (55). Slide a spring (53) over the plunger, inside the valve cylinder.
- d. Insert an O-ring (52) into a spring retainer (51).
- e. Install two O-rings (52) on the valve cylinder (55).
- f. Slide the assembled valve cylinder, plunger, and spring (53-55) into the spring retainer (51).
- g. Install an O-ring (56) on the spring retainer (51).
- h. Slide the complete cylinder-and-retainer assembly (51-56) into the piston assembly (59).
- i. Insert a return spring (50) into the piston assembly.
- j. Repeat the above procedure for the other two pistons.

4. Reassemble Pump Housing, Shaft Assembly, and Cylinder Casting

Note: Inspect the shaft seals (64) before continuing. If they look damaged in any way, replace them. We recommend changing the shaft seals whenever the camshaft assembly is removed from the pump housing. New shaft seals will be installed after the pump housing has been assembled over the camshaft and fastened to the cylinder casting (see Step 5 below). Both seals should be replaced at the same time. Remove the seals by pounding them out from inside the pump housing, then clean the seal bore in the housing using emery cloth or ScotchBrite™.

- a. Screw three 10-mm assembly studs (from the Wanner Tool Kit) into three of the four threaded holes in the **outer** ring of holes within the cylinder casting (25). Thread them in all the way, from the diaphragm side of the cylinder casting, until the head bottoms out against the face of the cylinder casting.
Apply a slight torque to them so they will resist rotation during the following steps.
- b. Place the cylinder casting face-down on a flat surface. It will rest on the heads of the three assembly studs just added. This is especially important if the diaphragms and pistons are already assembled to the cylinder casting. **Never lay the cylinder casting face-down with the weight of the casting and/or the pump housing on the diaphragms.**
- c. Insert the assembled pistons (50-59) into the cylinder casting. Check each piston to be sure all check balls (58) are in place.
- d. Note the location of the **outer** ring of holes in the cylinder casting and in the pump housing flange — in particular, the holes where capscrews (26) will be installed.
- e. Stand the camshaft assembly (62) on the cylinder casting (25), and place the seal protector (from the Wanner Tool Kit) over the end of the shaft.
Caution: The pilot bearing must be properly nested in the bearing race during assembly. If misaligned, the bearing will be damaged and the pump will fail within the first hours of operation.
- f. Using grease to retain it, install the O-ring (65) and slide the housing (30) down over the shaft and onto the threaded studs (from step “a”). Be sure the holes in the housing and the cylinder casting are properly aligned.
- g. Install washers (6) and nuts (31) on the threaded studs, but don’t tighten yet. You may want to insert two or more bolts (5) into the unthreaded holes of the housing and cylinder casting to help align the parts.
- h. Alternately tighten the three nuts (31) to evenly draw the housing down to the cylinder casting. Be sure the O-ring (65) stays in place. Also, as you tighten the nuts keep checking the shaft alignment by turning the shaft (use the rotator in the Wanner Tool Kit). If the shaft begins to bind and become difficult to turn, back off the nuts and realign the shaft. When the pump housing is tight against the cylinder casting, you should still be able to turn the shaft smoothly.
- i. After all three nuts (31) are tightened, insert a capscrew (26), with washer (6), into the unused threaded hole in the cylinder casting. Then remove the assembly stud, washer, and nut that are opposite the capscrew just added, and replace them with another capscrew and washer. Finally, remove the other two assembly studs, which should be on opposite sides of the pump housing from each other, and replace them with capscrews and washers. Torque the capscrews to 25 ft-lbs (34 N-m).
- j. Turn the shaft again to check its alignment.

H-25-SD/G-25-SD Service (Hydraulic End)

5. Replace Shaft Seals

- a. Apply a thin film of grease on the seal protector tool (from the Wannan Tool Kit). Slide both seals onto the tool, with the spring side of the seals toward the open end of the tool.
Apply a heavier coat of grease between the seals and press them together. Wipe off any excess grease that may squeeze out onto the outside of the seals.
- b. Apply a coating of Loctite® High-Performance Pipe Sealant with Teflon, or a comparable product, to the outer surface of both seals and the inside surface of the opening in the pump housing where the seals will rest.
- c. Apply a light film of grease to the drive shaft. Slide the seal protector tool (with the two seals) over the end of the shaft.
- d. Slide the seal inserter tool (from the Wannan Tool Kit) over the seal protector tool, and press the seals completely into place. Tap the tool with a soft mallet to firmly seat the seals.

6. Adjust Camshaft Endplay

- a. If the three set screws (24) are in the cylinder casting (25), remove and clean them.
- b. Insert the centerbolt (1) into the hole in the center of the cylinder casting. Turn it in to move the bearing adjusting plate (61) and cup tight against the bearing cone.
- c. Back out the centerbolt **two** full turns, then turn it back in again until it is tight against the adjusting plate (61) to ensure the proper fit.
- d. Back out the centerbolt **exactly 1/4** of a turn.
- e. With a plastic mallet (or a regular mallet and wooden board) to prevent damage to the shaft, rap the end of the shaft three or four times. This will provide about .006 in. (0.15 mm) endplay in the shaft.
- f. Apply removable threadlocker to the threads of the three cleaned set screws (24), then screw them into the cylinder casting until they contact the bearing adjusting plate (61).
- g. Remove the centerbolt (1).

7. Install Plungers

Note: If the plungers (23) have been removed from the valve plungers (54), do not reuse them. Install new ones instead.

- a. Rotate the pump shaft so the piston is in the top-dead-center position.

- b. With the nut turned back toward the hex head of the plunger guide lifter, slide the plunger guide sleeve over the large thread of the lifter (both the lifter and guide are included in the Wannan Tool Kit).
- c. Place a plunger on the exposed screw end of the plunger guide lifter. The larger-diameter side of the plunger should face the tool.
- d. Screw the guide (with the plunger) into the valve plunger (54) until tight.
- e. Hold the plunger guide sleeve with a 1-in. (26-mm) open-end wrench. Turn the hex nut down with a 3/4-in. (19 mm) open-end wrench to force the plunger to seat on the valve plunger. This is a press-fit — when installed, the plunger should be tight against the shoulder of the valve plunger.
Note: Do *not* remove the plunger guide until the diaphragm is installed (see below).
- f. Install the diaphragm as outlined below, then repeat the procedure for the other two plungers and diaphragms.

8. Reinstall Diaphragms

- a. With the plunger guide tool still screwed into the valve plunger (54), pull the valve plunger up until the cross-holes in the valve plunger are exposed.
- b. Insert a diaphragm Allen wrench (from the Wannan Tool Kit), or a similar dowel-type object, through the holes—to hold the plunger (23) away from the cylinder casting, and to keep the valve plunger from turning when the diaphragm is being installed.
- c. Place the diaphragm (22) onto the plunger (23), ridge-side out.
- d. Center the diaphragm follower (21) on the diaphragm.
- e. Place the O-ring (20) onto the follower screw (19).
- f. Apply a small amount of threadlocker to the threads of the follower screw.
- g. Insert the follower screw (with O-ring) through the diaphragm follower (21) and diaphragm (22), and screw it into the valve plunger (54).
- h. Hold the diaphragm Allen wrench, and torque the follower screw to 18 in.-lbs (2.0 N-m).
- i. Repeat the above procedure for the plungers and diaphragms of the other two cylinders.
- j. Fill the reservoir with fresh oil and prime the pump, as outlined in the Fluid End Service Section.

9. Reassemble Pump Head

Reassemble the pump head as outlined in the Fluid End Service Section.

H-25-SD/G-25-SD Troubleshooting

Cavitation

- Inadequate fluid supply because:
 - Inlet line collapsed or clogged
 - Clogged line strainer
 - Inlet line too small or too long
 - Air leak in inlet line
 - Worn or damaged inlet hose
 - Suction line too long
 - Too many valves and elbows in inlet line
- Fluid too hot for inlet suction piping system.
- Air entrained in fluid piping system.
- Aeration and turbulence in supply tank.
- Inlet vacuum too high (refer to "Inlet Calculations", page 4).

Symptoms of Cavitation

- Excessive pump valve noise
- Premature failure of spring or retainer (14,16)
- Volume or pressure drop
- Rough-running pump
- Premature failure of diaphragms (22)
- Piston return spring failure (inside hydraulic end)

Drop in Volume or Pressure

A drop in volume or pressure can be caused by one or more of the following:

- Air leak in suction piping
- Clogged suction line or suction strainer
- Suction line inlet above fluid level in tank
- Inadequate fluid supply
- Pump not operating at proper RPM
- Relief valve bypassing fluid
- Worn pump valve parts
- Foreign material in inlet or outlet valves
- Loss of oil prime in cells because of low oil level
- Ruptured diaphragm
- Cavitation
- Warped manifold from overpressurized system
- O-rings forced out of their grooves from overpressurization
- Air leak in suction line strainer or gasket
- Cracked suction hose.
- Empty supply tank
- Excessive aeration and turbulence in supply tank
- Cavitation
- Abrasives in the fluid
- Valve incompatible with corrosives in the fluid
- Pump running too fast
- Worn and slipping drive belt(s)
- Worn spray nozzle(s)
- Cracked cylinder casting

Pump Runs Rough

- Worn pump valves
- Airlock in outlet system
- Oil level low
- Wrong weight of oil for cold operating temperatures (change to lighter weight)
- Cavitation
- Air in suction line
- Restriction in inlet/suction line
- Hydraulic cells not primed after changing diaphragm
- Foreign material in inlet or outlet valve
- Damaged diaphragm
- Fatigued or broken valve spring (14)
- Broken piston return spring (inside hydraulic end)

Premature Failure of Diaphragm

- Frozen pump
- Puncture by a foreign object
- Elastomer incompatible with fluid being pumped
- Pump running too fast
- Excess pressure
- Cavitation
- Broken piston return spring (50)

Water (or Process Fluid) in Oil Reservoir

- Condensation
- Ruptured diaphragm
- Hydraulic cell not properly primed after diaphragm replacement
- Frozen pump
- Diaphragm screw O-ring (20) missing or cracked
- Cracked cylinder casting

Strong Water (or Process Fluid) Pulsations

NOTE: Small pulsations are normal in single-acting pumps with multiple pumping chambers.

- Foreign object lodged in pump valve
- Loss of prime in hydraulic cell because of low oil level
- Air in suction line
- Valve spring (14) broken
- Cavitation
- Aeration or turbulence in supply tank

H-25-SD/G-25-SD Troubleshooting

Valve Wear

- Normal wear
- Cavitation
- Abrasives in the fluid
- Valve incompatible with corrosives in the fluid
- Pump running too fast
- Washer (44) missing or dislodged from position between spring and valve

Loss of Oil

- External seepage
- Rupture of diaphragm
- Frozen pump
- Diaphragm screw O-ring (20) missing or cracked
- Worn shaft seal
- Oil drain piping or fill cap loose
- Valve plate and manifold bolts loose

Premature Failure of Valve Spring or Retainer

- Cavitation
- Foreign object in the pump
- Pump running too fast
- Spring/retainer material incompatible with fluid being pumped
- Excessive inlet pressure
- Washes (17, 44) missing or dislodged from position

Limited Warranty

Wanner Engineering, Inc. extends to the original purchaser of equipment manufactured by it and bearing its name, a limited one-year warranty from the date of purchase against defects in material or workmanship, provided that the equipment is installed and operated in accordance with the recommendations and instructions of Wanner Engineering, Inc. Wanner Engineering, Inc. will repair or replace, at its option, defective parts without charge if such parts are returned with transportation charges prepaid to Wanner Engineering, Inc., 1204 Chestnut Avenue, Minneapolis, Minnesota 55403.

This warranty does not cover:

1. The electric motors (if any), which are covered by the separate warranties of the manufacturers of these components.
2. Normal wear and/or damage caused by or related to abrasion, corrosion, abuse, negligence, accident, faulty installation or tampering in a manner which impairs normal operation.
3. Transportation costs.

This limited warranty is exclusive, and is in lieu of any other warranties (express or implied) including warranty of merchantability or warranty of fitness for a particular purpose and of any noncontractual liabilities including product liabilities based on negligence or strict liability. Every form of liability for direct, special, incidental or consequential damages or loss is expressly excluded and denied.



WANNER ENGINEERING, INC.

1204 Chestnut Avenue, Minneapolis, MN 55403
TEL: (612) 332-5681 FAX: (612) 332-6937
TOLL-FREE FAX [US only]: (800) 332-6812

www.hydra-cell.com

email: sales@wannereng.com

Document Fax Back System (510) 745-0440

H25-991-2406 Rev. C

©2001 Wanner Engineering, Inc. Printed in USA 5/01