

**INSTALLATION & SERVICE**  
**G40-991-2400B**

# **Hydra-Cell<sup>®</sup>**

## **INDUSTRIAL PUMPS**

**Models: D-40, G-40**

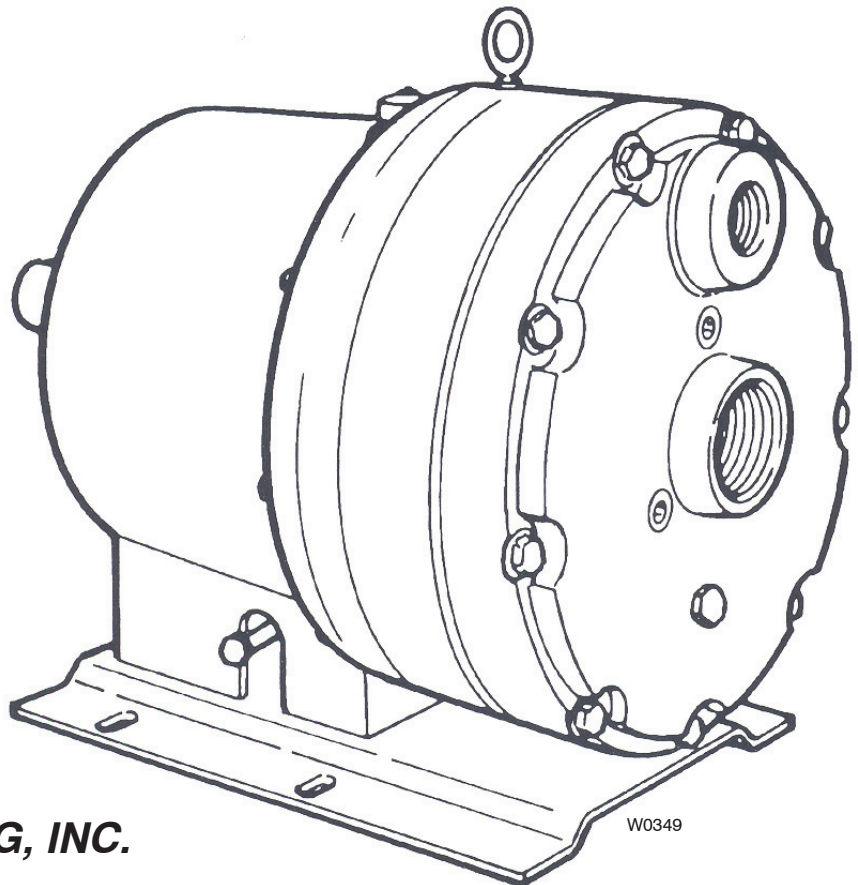

W0349



**WANNER ENGINEERING, INC.**

1204 Chestnut Avenue, Minneapolis, MN 55403  
TEL: (612) 332-5681 FAX: (612) 332-6937  
TOLL-FREE FAX [US only]: (800) 332-6812

[www.hydra-cell.com](http://www.hydra-cell.com)  
email: [sales@wannereng.com](mailto:sales@wannereng.com)

# D/G-40 Contents

---

	Page
Installation .....	2
Maintenance.....	5
Service (Fluid End) .....	6
Service (Hydraulic End) .....	9
Troubleshooting.....	11

## D/G-40 Installation

---

**NOTE: The numbers in parentheses are the Reference Numbers on the exploded view illustrations.**

### Location

Locate the pump as close to the supply source as possible.

Install it in a lighted, clean space where it will be easy to inspect and maintain. Allow room for checking the oil level, changing the oil, and removing the pump head (manifold, valve plate, and related items).

### Mounting

Do not exceed the maximum pump speed.

The pump shaft rotation is reversible.

To prevent vibration, mount the pump securely on a level rigid base.

On a belt-drive system, align the sheaves accurately: poor alignment wastes horsepower and shortens the belt and bearing life. Make sure the belts are properly tightened, as specified by the belt manufacturer.

On a direct-drive system, align the shafts accurately. Unless otherwise specified by the coupling manufacturer, maximum parallel misalignment should not exceed .015" and angular misalignment should be held to 1 degree maximum. Careful alignment extends life of the coupling, pump, shafts, and support bearings. Consult coupling manufacturer for exact alignment tolerances.

### Important Precautions

**Adequate Fluid Supply.** To avoid cavitation and premature pump failure, be sure that the pump will have an adequate fluid supply and that the inlet line will not be obstructed. See "Inlet Piping".

**Positive Displacement.** This is a positive-displacement pump. To avoid severe system damage if the discharge line ever becomes blocked, install a relief valve downstream from the pump. See "Discharge Piping".

**Safety Guards.** Install adequate safety guards over all pulleys, belts, and couplings. Follow all codes and regulations regarding installation and operation of the pumping system.

**Shut-Off Valves.** Never install shut-off valves between the pump and discharge pressure regulator, or in the regulator bypass line.

**Freezing Conditions.** Protect the pump from freezing. See also the Maintenance Section.

Consult the Factory for the following situations:

- Extreme temperature applications (above 160° F or below 40° F)
- Pressure feeding of pumps
- Viscous or abrasive fluid applications
- Chemical compatibility problems
- Hot ambient temperatures (above 110° F)
- Conditions where pump oil may exceed 200° F because of a combination of hot ambient temperatures, hot fluid temperature, and full horsepower load — an oil cooler may be required

### Inlet Piping (Suction Feed)

**CAUTION: When pumping at temperatures above 160° F (71° C), use a pressure-feed system.**

Install draincocks at any low points of the suction line, to permit draining in freezing conditions.

Provide for permanent or temporary installation of a vacuum gauge to monitor the inlet suction. Vacuum at the pump inlet should not exceed **7 in. Hg (180 mm Hg)**. With PTFE diaphragms, the inlet must be flooded.

### Supply Tank

Use a supply tank that is large enough to provide time for any trapped air in the fluid to escape. The tank size should be at least twice the maximum pump flow rate.

Isolate the pump and motor stand from the supply tank, and support them separately.

Install a separate inlet line from the supply tank to each pump.

Install the inlet and bypass lines so they empty into the supply tank below the lowest water level, on the opposite side of the baffle from the pump suction line.

If a line strainer is used in the system, install it in the inlet line to the supply tank.

To reduce aeration and turbulence, install a completely submerged baffle plate to separate the incoming and outgoing liquids.

# D/G-40 Installation

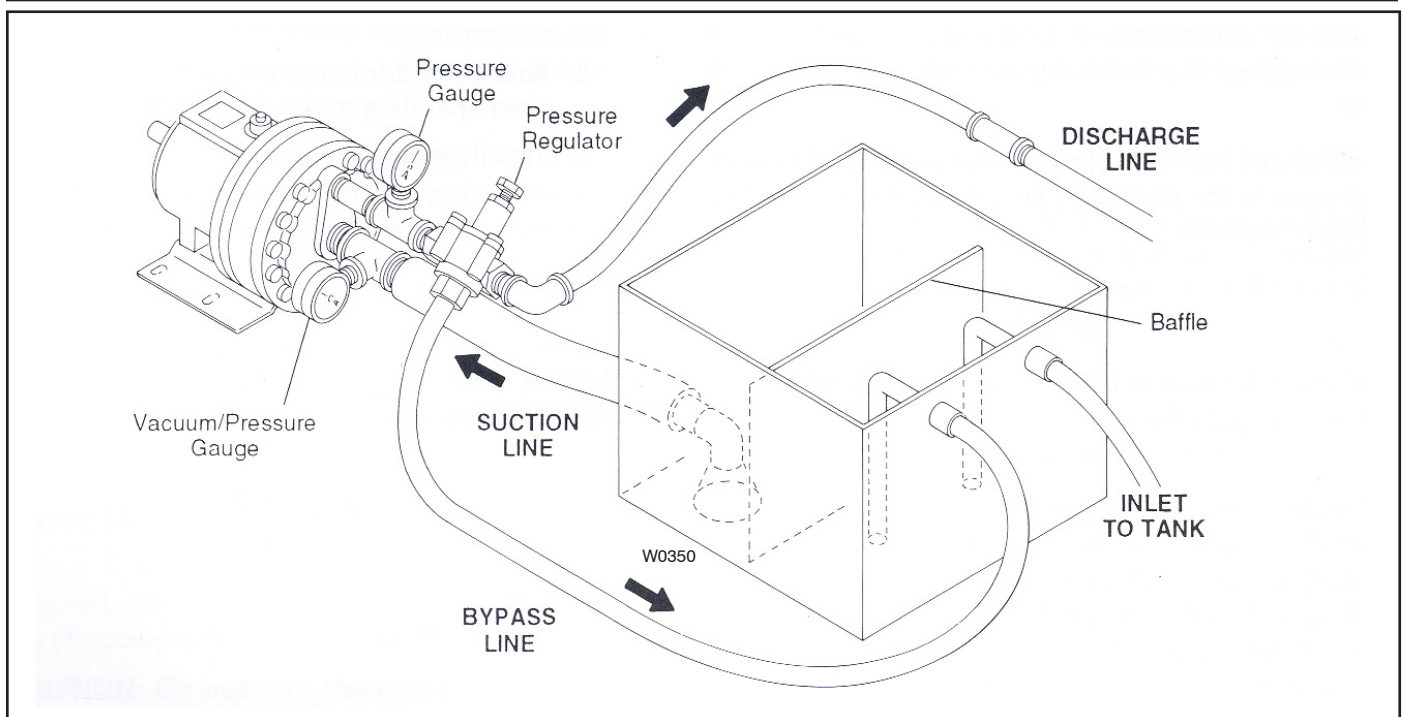

Install a vortex breaker in the supply tank, over the outlet port to the pump.

Place a cover over the supply tank, to prevent foreign objects from falling into it.

## Hose and Routing

Size the suction line at least one size larger than the pump inlet, and so that the velocity will not exceed 1-3 ft/sec (0.3 to 0.9 m/s):

For pipe in inches:  $\text{Velocity (ft/sec)} = 0.408 \times \text{GPM}/\text{Pipe ID}^2$

For pipe in mm:  $\text{Velocity (m/sec)} = 21.2 \times \text{LPM}/\text{Pipe ID}^2$

Keep the suction line as short and direct as possible.

Use flexible hose and/or expansion joints to absorb vibration, expansion, or contraction.

If possible, keep the suction line level. Do not have any high points to collect vapor unless these high points are vented.

To reduce turbulence and resistance, do not use 90° elbows. If turns are necessary in the suction line, use 45° elbows or arrange sweeping curves in the flexible inlet hose.

If a block valve is used, be sure it is fully opened so that the flow to the pump is not restricted. The opening should be at least the same diameter as the inlet plumbing ID.

Do not use a line strainer or filter in the suction line unless regular maintenance is assured. If used, it should have a free-flow area of at least three times the free-flow area of the inlet.

Install piping supports where necessary to relieve strain on the inlet line and to minimize vibration.

## Inlet Piping (Pressure Feed)

Provide for permanent or temporary installation of a vacuum/pressure gauge to monitor the inlet vacuum or pressure. Pressure at the pump inlet should not exceed 40 psi (275 kPa); if it could get higher, install an inlet pressure reducing regulator.

Do **not** supply more than one pump from the same inlet line. Inlet Calculations

## Discharge Piping

**NOTE: Consult the Factory before manifolding two or more pumps together.**

### Hose and Routing

Size the discharge line one or two sizes larger than the pump discharge opening. Use the shortest, most-direct route for the discharge line.

Select pipe or hose with a **working pressure** rating of at least 1.5 times the maximum system pressure. **EXAMPLE:** Select a 1500-psi W.P.-rated hose for systems to be operated at 1000-psi-gauge pressure.

Use about 6 ft (1.8 m) of flexible hose between the pump and rigid piping to absorb vibration, expansion or contraction.

Support the pump and piping independently. Size the discharge line so that the velocity of the fluid will not exceed 8-10 ft/sec (2-3 m/sec):

For pipe in inches:  $\text{Velocity (ft/sec)} = 0.408 \times \text{GPM}/\text{Pipe ID}^2$

For pipe in mm:  $\text{Velocity (m/sec)} = 21.2 \times \text{LPM}/\text{Pipe ID}^2$

# D/G-40 Installation

## Pressure Regulation

**Install a pressure regulator or unloader in the discharge line.** Bypass pressure must not exceed the pressure limit of the pump.

Size the regulator so that, when fully open, it will be large enough to relieve the full capacity of the pump without overpressurizing the system.

Locate the valve as close to the pump as possible and ahead of any other valves.

Adjust the pressure regulating valve to no more than 10% over the maximum working pressure of the system. Do not exceed the manufacturer's pressure rating for the pump or regulator.

Route the bypass line to the supply tank, or to the suction line as far as possible from the pump (to reduce the chance of turbulence).

If the pump will be operating for a long time with the discharge closed and fluid bypassing, install a thermal protector in the bypass line (to prevent severe temperature buildup in the bypassed fluid).

**CAUTION: Never install shutoff valves in the bypass line or between the pump and pressure regulator or relief valve.**

Provide for permanent or temporary installation of a pressure gauge to monitor the discharge pressure at the pump.

For additional system protection, install a safety relief valve in the discharge line, downstream from the pressure regulator.

## Before Initial Start-Up

Before you start the pump, be sure that:

- All shutoff valves are open, and the pump has an adequate supply of fluid.
- All connections are tight.
- The oil level is approximately 1 inch (2.5 cm) from the top of the fill port – so that the floor of the upper reservoir within the pump housing is flooded and the chamber itself is about 1/4 full, allowing for oil expansion as the pump runs and heats up.
- The relief valve on the outlet of the pump is adjusted so the pump starts under minimum pressure.
- All pulleys and belts are properly aligned, and belts are tensioned according to specification.
- All pulleys and belts have adequate safety guards.

## Initial Start-Up Procedure

1. Turn on power to the pump motor.
2. Check the inlet pressure or vacuum. Inlet vacuum must not exceed 7 in. Hg at 70°F (180 mm Hg at 21°C). Inlet pressure must not exceed 40 psi (275 kPa).
3. If you hear any erratic noise or if the flow is unsteady, refer to the Troubleshooting Section.
4. If the system has an air lock and the pump fails to prime:
  - a. Turn off the power
  - b. Remove the drain plug (2) on the bottom center of the manifold.

NOTE: Fluid may come out of this port when the plug is removed. Provide an adequate catch basin for fluid spillage, if required. Fluid will come out of this port when the pump is started, so we recommend that you attach adequate plumbing from this port so fluid will not be sprayed or lost. Use high-pressure-rated hose and fittings from this port. Take all safety precautions to assure safe handling of the fluid being pumped.

- c. Jog the system on and off until the fluid coming from this port is air-free.
  - d. Turn off the power.
  - e. Remove the plumbing that was temporarily installed, and reinstall the drain plug (2).
5. Adjust the discharge pressure regulator to the desired operating and bypass pressures.
  6. After the pressure regulator is adjusted, set the safety relief valve at 100 psi (7 bar) higher than the desired operating pressure. To verify this setting, adjust the discharge pressure regulator upward until the relief valve opens. Follow the recommendations in the above NOTE (step 4b) for handling the fluid that will come from the relief valve.
  7. Reset the discharge pressure regulator to the desired system pressure.
  8. Provide a return line from the relief valve to the supply tank, similar to the bypass line from the pressure regulator.

# D/G-40 Maintenance

## Daily

Check the oil level and the condition of the oil. The oil level is approximately 1 inch (2.5 cm) from the top of the fill port – so that the floor of the upper reservoir within the pump housing is flooded and the chamber itself is about 1/4 full, allowing for oil expansion as the pump runs and heats up.

Use the appropriate Hydra-Oil for the application (contact Wanner Engineering if in doubt).

**CAUTION: If you are losing oil but don't see any external leakage, or if the oil becomes discolored and contaminated, one of the diaphragms (22) may be damaged. Refer to the Fluid-End Service Section. Do not operate the pump with a damaged diaphragm.**

## Periodically

Change the oil after the first 100 hours of operation, and then according to the guidelines below. When changing, remove the pipe cap (34) at the bottom of the pump so all oil and accumulated sediment will drain out.

### Hours Between Oil Changes @ Various Process Fluid Temperatures

Pressure	RPM	<90°F (32°C)	<139°F (60°C)	<180°F (82°C)
<b>Metallic Pump Head</b>				
<800 psi (56 bar)	<800	6,000	4,000	2,000
	≤1200	3,000	2,000	1,500
<1200 psi (83 bar)	<800	3,000	2,000	1,500
	≤1200	1,500	—	1,000

**NOTE: Minimum oil viscosity for proper hydraulic end lubrication is 16-20 cST (80-100 SSU).**

**NOTE: Use of an oil cooler is recommended when process fluid and/or hydraulic end oil exceeds 180°F (82°C).**

**CAUTION: Do not turn the drive shaft while the oil reservoir is empty.**

Check the inlet pressure or vacuum periodically with a gauge. If vacuum at the pump inlet exceeds 7 in. Hg (180 mm Hg), check the inlet piping system for blockages. If the pump inlet is located above the supply tank, check the fluid supply level and replenish if too low.

**CAUTION: Protect the pump from freezing. Refer also to the "Shutdown Procedure".**

## Shutdown Procedure During Freezing Temperatures

Take all safety precautions to assure safe handling of the fluid being pumped. Provide adequate catch basins for fluid drainage and use appropriate plumbing from drain ports, etc. when flushing the pump and system with a compatible antifreeze.

1. Adjust the discharge pressure regulating valve so the pump runs under minimum pressure. Stop the pump.
2. Drain supply tank; open any draincocks in system piping and collect drainage; remove plug (2) from manifold and collect drainage.
3. Close draincocks in system piping and replace manifold plug.
4. Fill supply tank with enough antifreeze to fill system piping and pump.  
Note: disconnect the system return line from the supply tank and connect it to a separate reservoir.
5. Start the pump and allow it to run until the system is filled with antifreeze. Note: if the system has an airlock and the pump fails to prime, follow step 4 of the Initial Start-up Procedure to clear the air.
6. When mostly antifreeze is flowing from the system return line stop the pump. Connect the system return line back to the supply tank and circulate the antifreeze for a short period.
7. It is also good practice to change the oil in the Hydraulic End before storage for an extended period. This will remove

# D/G-40 Service (Fluid End)

**NOTE:** The number in parentheses are the Reference numbers on the illustration on the preceding page.

This section explains how to disassemble and inspect all easily-serviceable parts of the pump. Repair procedures for the hydraulic end (oil reservoir) of the pump are included in a later section of the manual.

**CAUTION:** Do not disassemble the hydraulic end unless you are a skilled mechanic. For assistance, contact Wanner Engineering (612-332-5681) or the distributor in your area.

**CAUTION:** Do not remove the four socket-head capscrews (25) that go through the back of the pump housing and thread into the cylinder housing, unless you are repairing the hydraulic end of the pump.

## Service Procedure

### 1. Remove Manifold and Valve Plate (5, 18)

- a. **Manifold.** Using 1/2 inch (14 mm) hex socket and box-end wrench, remove the centerbolts (1) and washers (if appropriate) in the center of the manifold. **Do not remove** the four socket-head capscrews. Remove the manifold.

**NOTE:** When you remove the valve plate in the following step, some oil will leak out from behind the diaphragms. Provide something to catch this oil leakage.

**CAUTION:** Don't turn the pump drive shaft while the manifold and valve plate are off the pump, except when removing diaphragms or repriming the hydraulic cells.

- b. Remove all nuts (31) and bolts (3) around the manifold. Do not remove the four bolts (25) that are installed through the back of the pump housing.
- c. Remove the manifold (5).
- d. Inspect the manifold for warping or wear around the inlet and outlet ports. If wear is excessive, replace the manifold or return it to Wanner Engineering for resurfacing.

To check if the manifold is warped, remove the O-rings and place a straightedge across it. A warped manifold should be replaced.

**Note:** Before removing the valve plate in steps e. and f. below, insert two bolts (3) from the shaft end of the pump, through two holes in the top of the cylinder casting (24), and into the valve plate (18). This will hold the valve plate in place when the socket head cap screws are removed.

- e. With a 3/8 inch (10 mm) hex head socket, remove the four socket head cap screws (17).
- d. Remove and inspect the valve plate (18).

### 2. Inspect Valves (8-15)

The three inlet and three outlet valve assemblies are identical, but face in opposite directions. Inspect them while they are still in the valve plate (18): look for excess wear on the valve seat (10) and valve (11), or for foreign material in the valve assembly.

If further inspection is necessary or if they must be replaced, remove them as outlined below.

#### MODEL D-40 AND G-40 VALVE ASSEMBLY

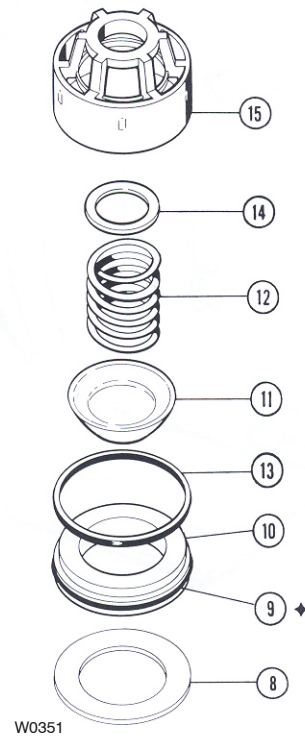

- ◆ O-ring (9) is shown installed on valve seat (10).

#### Remove Valves

- a. **Inlet (3 center valves).** From the front side of the valve plate (18), insert a seat remover (from the Wanner Tool Kit) through the valve seat (10), and pull on it. The valve seat (10), will come loose, followed by the valve (11), valve spring (12), washer (14) and retainer (15).
- b. **Outlet (3 outer valves).** Grasp and pull the spring retainer (15) from the front side of the valve plate.

Remove the retainer, washer (14), valve spring (12) and valve (11).

Use the wrench-operated Valve Seat Removal Tool included in the Wanner Tool Kit to remove the valve seat (10).

# D/G-40 Service (Fluid End)

## Disassemble and Inspect Valves

- c. Remove the O-ring (13).
- d. Insert a large screwdriver between the spring retainer (15) and valve seat (10), and twist.
- e. Inspect the O-rings. Replace if worn.
- f. Inspect the valves and valve seats for wear, and replace if necessary. Replace the valve springs and spring retainers whenever the valves are replaced.

## Reassemble Valves

- g. Apply grease to the outside of the valve seat and O-ring (9), then reassemble the valve assemblies.

## Reinstall Valves

- h. Clean the valve ports and shoulders with emery cloth, and lubricate with grease or petroleum jelly.
- i. **Inlet (3 center valves).** Insert the valve assemblies into the valve plate, retainer first.
- j. **Outlet (3 outer valves).** Insert the valve assemblies into the valve plate, valve seat first.

## 3. Inspect and Replace Diaphragms (22)

- a. Lift the diaphragm by one edge, and turn the pump shaft until the diaphragm pulls up. This will expose machined cross-holes in the valve plunger (52) behind the diaphragm.
- b. Insert the Valve Plunger Holder (from the Wanner Tool Kit) through the top hole, to hold the diaphragm up.
- c. Grasp the Plunger Holder so the valve plunger (52) won't rotate, remove the screw (19), O-ring (20), and follower (21) from the center of the diaphragm.
- d. Remove the diaphragm and inspect it carefully. A damaged diaphragm generally indicates a pumping system problem, and replacing only the diaphragm will not solve the larger problem. Inspect the diaphragm for the following:
  - **Half-moon marks.** Usually caused by cavitation of the pump (refer to "Troubleshooting").
  - **Concentric circular marks.** Usually caused by cavitation of the pump (refer to "Troubleshooting").
  - **Small puncture.** Usually caused by a sharp object in the fluid, or by an ice particle.
  - **Diaphragm pulled away** from the center screw or from the cylinder sides. Usually caused by fluid being frozen in the pump, or by overpressurization of the pump.
  - **Diaphragm becoming stiff** and losing flexibility. Usually caused by pumping a fluid that is incompatible with the diaphragm material.
  - **Slice in ridge of diaphragm.** Usually occurs when a diaphragm is operated at temperatures below its rated capability.
  - **Diaphragm edge chewed away.** Usually caused by overpressurizing the system.
- e. Inspect the plunger (23) for any rough surfaces or edges.

**Do not** remove the plunger from the plunger shaft. Smooth the surfaces and edges as necessary with emery cloth or a fine file, being careful to keep particles out of the pump.

**CAUTION: If a diaphragm was damaged and foreign material or water has entered the oil reservoir, do not operate the pump. Check all diaphragms, then flush the reservoir completely (as outlined below) and refill it with fresh oil. Never let the pump stand with foreign material or water in the reservoir, or with the reservoir empty.**

- f. Install a new diaphragm ridge-side out. We recommend that you not reuse old diaphragms, because the material may have taken a compression set and thus will not seal properly.
- g. Clean the screw (19), follower (21), and the threads in the valve plunger. Remove any oil from the valve plunger. Apply a medium-strength threadlocker (Loctite® 242) to the screw (19). Re-install the screw, O-ring (20), and follower, and tighten the screw.
- h. Repeat the above inspection and replacement procedure with the other two diaphragms.

## 4. Flush Contaminates from Hydraulic End

### (only if a diaphragm has ruptured)

- a. With the valve plate and manifold still removed (see above), remove the oil drain cap (34). Allow all oil and contaminate to drain out (catch and dispose of it properly).
- b. Fill the reservoir with kerosene or solvent, manually turn the pump shaft to circulate the kerosene, and drain. Catch and dispose of the contaminated fluid properly.

**CAUTION: If you have EPDM diaphragms, or if food-grade oil is in the reservoir, do not use kerosene or solvents. Instead, flush with the same lubricant that is in the reservoir. Pumps with EPDM diaphragms have an "E" as the 7th digit of the Model No.**
- c. Repeat the flushing procedure (step b).
- d. Fill the reservoir with fresh oil, manually turn the pump shaft to circulate the oil, and drain once again. Catch the oil and dispose of it properly.
- e. Refill the reservoir. If the oil appears milky, there is still contaminate in the reservoir. Repeat the flushing procedure until the oil appears clean.

## 5. Prime the Hydraulic Cells

- a. With the pump horizontal, and the fluid-end head removed, fill the reservoir with the appropriate Hydra-oil for the application. Have a catch basin for oil that leaks from behind the diaphragms when priming. Catch the oil and dispose of it properly; **do not reuse it.**

# D/G-40 Service (Fluid End)

---

- b. All air in the oil within the hydraulic cell (behind the diaphragms) must be forced out by turning the shaft (and thus pumping the piston). A shaft rotator is included in the Wanner Tool Kit. Turn the shaft until a **bubble-free** flow of oil comes from behind all the diaphragms. Watch the oil level in the reservoir; if it gets too low during priming, air will be drawn into the pistons (inside the hydraulic end) and will cause the pump to run rough.
- c. Wipe excess oil from the cylinder casting and diaphragms.
- d. Ensure that the oil is 1 inch (25 mm) from the top of the fill port.
- e. Replace oil fill cap (27).

## 6. Reinstall Valve Plate and Manifold (18, 5)

- a. Insert two bolts (3) from the shaft end of the pump, through the top two holes of the pump.
- b. Hang the valve plate on these two bolts.
- c. Insert four socket head cap screws (17) through the valve plate, and hand tighten the valve plate to the cylinder casting. Watch the alignment.
- d. Using petroleum jelly or grease, install the outlet valve O-rings (16) and centerbolt O-rings (6) on the valve plate.
- e. Again using petroleum jelly or grease, install the manifold O-ring (7) on the manifold.
- f. Hang the manifold on the two bolts (3).
- g. Install centerbolts (1) and washers if appropriate. Torque to 180 ft-lbs (240 N-m).
- h. Install the bolts (3), washers (4), and nuts (31) around the edge of the manifold. Torque to 90 ft-lbs (120 N-m).
- i. Recheck all bolts for tightness.

# D/G-40 Service (Hydraulic End)

**NOTE:** The number in parentheses are the Reference numbers on the illustrations in the Parts Manual.

This section explains how to disassemble and inspect the hydraulic end (oil reservoir) of the pump.

**CAUTION:** Do not disassemble the hydraulic end unless you are a skilled mechanic. For assistance, contact Wanner Engineering (612-332-5681) or the distributor in your area.

**CAUTION:** The four bolts (25) that screw through the back of the pump housing into the cylinder housing (24) hold these parts together. Do not remove these four screws except when repairing the hydraulic end.

**NOTE:** The following service procedures refer several times to the Wanner Tool Kit. We strongly urge you **not to try to repair** the hydraulic end of the pump without using the tools in this Kit (available from Wanner Engineering or your local distributor).

## Service Procedure

### 1. Remove Pump Housing

- a. Remove the head of the pump and diaphragms as outlined in the Fluid End Service Section.
- b. Drain the oil from the pump housing by removing the drain plug (34). Dispose of the oil properly.
- c. Remove the baseplate (35).
- d. Set the hydraulic end of the pump face-down on the cylinder casting (24).
- e. Check the shaft for sharp burrs. Smooth any burrs, to prevent scarring the housing seals (64) when you disassemble the pump.
- f. Remove the bolts (25) that secure the pump housing to the cylinder casting (remove two opposite bolts at a time, loosening them evenly). The piston return springs (49) will force the cylinder casting and pump housing apart. The bearing adjusting plate (61) and disc springs (60) may fall out.
- g. Lift off the pump housing (30).
- h. Inspect the cam assembly (62), and the bearing race in the rear of the pump housing. If the bearings are pitted or binding, or if the pump housing race is worn, contact Wanner Engineering.

### 2. Disassemble Pistons

- a. With the pump housing removed (see above), turn the cylinder casting (24) over and set it on a flat surface, piston side down. Be careful so the pistons don't separate from the cylinder casting.
- b. Remove the plunger (23) from the valve plunger (52). The plunger is press-fit on the valve plunger: (see the Fluid End Service Section), use a flat-tipped rod or punch to tap the valve plunger in the middle of the plunger. With light tapping, the plunger (23) should slip off the valve plunger.

The hydraulic piston assembly (49-58) can now be disassembled. Inspect all parts, and replace all O-rings and any other part that are worn or damaged.

- c. Repeat step b. for the remaining pistons.

### 3. Reassemble Pistons

**NOTE:** When reassembling the hydraulic pistons, use new plungers (23). They are press-fit onto the valve plungers (52) and are not reusable.

- a. Drop a ball (57) into each opening in the bottom of the piston assembly (58).  
**NOTE:** Using grease on the O-rings, and lubricating the parts, will aid in assembly.
- b. Insert a retaining washer (56) and O-ring (55) to hold the balls in place.
- c. Insert a valve plunger (52) into the valve cylinder (54). Slide a spring (51) over the valve plunger, inside the valve cylinder.
- d. Insert an O-ring (53) into the spring retainer (50).
- e. Install an O-ring on a valve cylinder.
- f. Lubricate the inside of a spring retainer, then slide the assembled valve cylinder, plunger, and spring (51-54) into the retainer.
- g. Lubricate the inside of wall of the piston.
- h. Slide the complete cylinder-and-retainer assembly (50-55) into the piston assembly (58).
- i. Insert a piston return spring (49) into the piston assembly.
- j. Repeat the above procedure for the other two pistons.

### 4. Remove Shaft Seals (64)

Inspect the shaft seals (64) before continuing. If they look damaged in any way, replace them. Remove by pounding them out from inside the pump housing. Replace both shaft seals at the same time. Clean the bore in the housing using emery cloth or Scotch-Brite™.

### 5. Reassemble Pump Housing and Cylinder Casting

- a. Place the cylinder casting (24) face-down on two boards, avoiding contact between the diaphragms and boards.
- b. Insert the disc springs (60) and bearing adjusting plate (61) into the cylinder casting. If they don't stick together as a unit, reassemble them, pack them with grease and hold them together while inserting them into the cylinder casting.

Insert the small bearing cup with the larger inside diameter facing **out**. The bearing cup must be flush with or lower than the cylinder casting.

- c. Insert the assembled pistons (49-58) into the cylinder casting.
- d. Note the location of the **outer** ring of holes in the cylinder casting and in the pump housing flange - in particular, the holes where bolts (25) will be installed.
- e. Stand the camshaft assembly (62) on the cylinder casting (24).

**Caution:** The pilot bearing **MUST** be properly nested in the bearing race during assembly. If misaligned, the bearing will be damaged and the pump will fail within the first hours of operation.

# D/G-40 Service (Hydraulic End)

- f. Wrap the seal protector bag (part of Wanner Tool Kit) over the shaft.
- g. Install the O-ring (65) into the pump housing (30), using grease or petroleum jelly to hold it in place.  
Slide the pump housing down over the shaft. Be sure the holes in the pump housing and the cylinder casting are properly aligned.
- h. Drop the bolts through the four appropriate holes in the pump housing (30). Screw the bolts (from the Wanner Tool Kit) into the four threaded holes in the cylinder casting, but don't tighten them yet. You may want to insert a few bolts (3) into the unthreaded holes of the pump housing and cylinder casting (24) to help align the parts.
- i. Alternately tighten the bolts to evenly draw the pump housing down to the cylinder casting. Be sure the O-ring (65) stays in place.

Also, as you tighten the nuts keep checking the shaft alignment by turning the shaft (use the rotator in the Wanner Tool Kit). If the shaft begins to bind and becomes difficult to turn, back off the nuts and realign the shaft. When the pump housing is tight against the cylinder casting you should be able to turn the shaft smoothly.

- j. After all the bolts are tightened, remove two opposite bolts. Insert two cap screws (25) with washers into the same holes, and tighten.  
Remove the two remaining bolts, and replace them with cap screws.
- k. Turn the shaft again to check its alignment.

## 6. Install Shaft Seals (64)

- a. Apply an anaerobic sealant or bearing retaining compound (such as Loctite® 601 or 609) to the outer surface of both seals and the inside surface of the opening in the pump housing where the seals will rest.
- b. With a soft mallet and the larger diameter side of the flat plate, tap the first seal (with its spring side into the pump) into the housing. With the reverse side of the plate, push the seal 1/8 inch (3 mm) further into the housing.
- c. Pack the inside (spring side) of the second seal half-full with grease. With the larger diameter of the plate, tap the second seal flush with the pump housing (30).

## 7. Reinstall Plungers (23)

**NOTE: If the plungers (23) have been removed from the valve plungers (52), do not reuse them. Install new ones instead.**

- a. With the pump shaft appropriately rotated, place a plunger (23) onto the exposed screw end of the Plunger Guide Lifter Tool (from the Wanner Tool Kit). The flat side of the plunger should face the tool.
- b. Screw the Guide Tool (with the plunger) into the valve plunger (52) until tight.
- c. Pull the valve plunger up until its cross holes are exposed. Insert the Valve Plunger Holder (from the Wanner Tool Kit) through the top cross hole.

- d. Hold the bottom of the guide with a 1 inch (25 mm) wrench, and turn the top of the guide with a 9/16 inch (15 mm) wrench. Press the plunger onto the valve plunger (52). This is a press fit. When installed, the plunger should be tight against the shoulder of the valve plunger.

**Note: Do not remove the plunger guide until the diaphragm is installed (see following).**

- e. Install the diaphragm as outlined following, then repeat the procedure for the other two plungers and diaphragms.

## 8. Reinstall Diaphragms (22)

**NOTE:** Keep the Valve Plunger Holder through the valve plunger (52), as described above under "Reinstall Plungers".

- a. Place the diaphragm (22) onto the plunger (23), ridge side out.
- b. Center the follower (21) on the diaphragm.
- c. Place the O-ring (20) onto the follower screw (19).
- d. Apply a small amount of threadlocker (e.g., Loctite 242) to the threads of the follower screw.
- e. Insert the follower screw, with its O-ring, through the follower and diaphragm. Then screw it into the valve plunger (52).
- f. Hold the Valve Plunger Holder and tighten the follower screw to 18 in-lbs (200 N-m).
- g. Repeat the above procedure for the other two cylinders.
- h. Fill the reservoir with fresh oil and prime the pump, as outlined in the Fluid-End Service Section.

## 9. Reassemble Pump Head

Reassemble the pump head as outlined in the Fluid End Service Section.

# D/G-40 Troubleshooting

---

## Cavitation

- Inadequate fluid supply because:
  - Inlet line collapsed or clogged
  - Clogged line strainer
  - Inlet line too small or too long
  - Air leak in inlet line
  - Worn or damaged inlet hose
  - Suction line too long
  - Too many valves and elbows in inlet line
  - NPSHa is less than NPSHr
- Fluid too hot for inlet suction piping system.
- Air entrained in fluid piping system.
- Aeration and turbulence in supply tank.
- Inlet vacuum too high

## Symptoms of Cavitation

- Excessive pump valve noise
- Premature failure of spring or retainer
- Volume or pressure drop
- Rough-running pump

## Drop in Volume or Pressure

A drop in volume or pressure can be caused by one or more of the following:

- Air leak in suction piping
- Clogged suction line or suction strainer
- Suction line inlet above fluid level in tank
- Inadequate fluid supply
- Pump not operating at proper RPM
- Relief valve bypassing fluid
- Worn pump valve parts
- Foreign material in inlet or outlet valves
- Loss of oil prime in cells because of low oil level
- Ruptured diaphragm
- Cavitation
- Warped manifold from overpressurized system
- O-rings forced out of their grooves from overpressurization
- Air leak in suction line strainer or gasket
- Cracked suction hose.
- Empty supply tank
- Excessive aeration and turbulence in supply tank
- Worn and slipping drive belt(s)
- Worn spray nozzle(s)

## Pump Runs Rough

- Worn pump valves
- Airlock in outlet system
- Oil level low
- Wrong weight of oil for cold operating temperatures (change to lighter weight)
- Cavitation
- Air in suction line
- Restriction in inlet/suction line
- Hydraulic cells not primed after changing diaphragm

- Foreign material in inlet or outlet valve
- Damaged diaphragm
- Fatigued or broken valve spring

## Premature Failure of Diaphragm

- Frozen pump
- Puncture by a foreign object
- Elastomer incompatible with fluid being pumped
- Pump running too fast
- Excess pressure

## Water (or Process Fluid) in Oil Reservoir

- Condensation
- Ruptured diaphragm
- Hydraulic cell not properly primed after diaphragm replacement
- Frozen pump

## Water (or Process Fluid) Pulsations

**NOTE: Small pulsations are normal in single-acting pumps with multiple pumping chambers.**

- Foreign object lodged in pump valve
- Loss of prime in hydraulic cell because of low oil level
- Air in suction line
- Valve spring broken
- Cavitation
- Aeration or turbulence in supply tank

## Valve Wear

- Normal wear from high-speed operation
- Cavitation
- Abrasives in the fluid
- Valve incompatible with corrosives in the fluid
- Pump running too fast

## Loss of Oil

- External seepage
- Rupture of diaphragm
- Frozen pump
- Worn shaft seal
- Oil drain piping or fill cap loose.
- Valve plate and manifold bolts loose

## Premature Failure of Valve Spring or Retainer

- Cavitation
- Foreign object in the pump
- Pump running too fast
- Spring/retainer material incompatible with fluid being pumped

### **Limited Warranty**

Wanner Engineering, Inc. extends to the original purchaser of equipment manufactured by it and bearing its name, a limited one-year warranty from the date of purchase against defects in material or workmanship, provided that the equipment is installed and operated in accordance with the recommendations and instructions of Wanner Engineering, Inc. Wanner Engineering, Inc. will repair or replace, at its option, defective parts without charge if such parts are returned with transportation charges prepaid to Wanner Engineering, Inc., 1204 Chestnut Avenue, Minneapolis, Minnesota 55403.

This warranty does not cover:

1. The electric motors (if any), which are covered by the separate warranties of the manufacturers of these components.
2. Normal wear and/or damage caused by or related to abrasion, corrosion, abuse, negligence, accident, faulty installation or tampering in a manner which impairs normal operation.
3. Transportation costs.

This limited warranty is exclusive, and is in lieu of any other warranties (express or implied) including warranty of merchantability or warranty of fitness for a particular purpose and of any noncontractual liabilities including product liabilities based on negligence or strict liability. Every form of liability for direct, special, incidental or consequential damages or loss is expressly excluded and denied.



**WANNER ENGINEERING, INC.**

1204 Chestnut Avenue, Minneapolis, MN 55403  
TEL: (612) 332-5681 FAX: (612) 332-6937  
TOLL-FREE FAX [US only]: (800) 332-6812

www.hydra-cell.com  
email: sales@wannereng.com

© 1999 Wanner Engineering, Inc. Printed in USA  
G40-991-2400B 1/1999, Revised 12/2006