

INSTALLATION & SERVICE

Hydra-Cell[®]

INDUSTRIAL PUMPS

Models: D-35/G-35

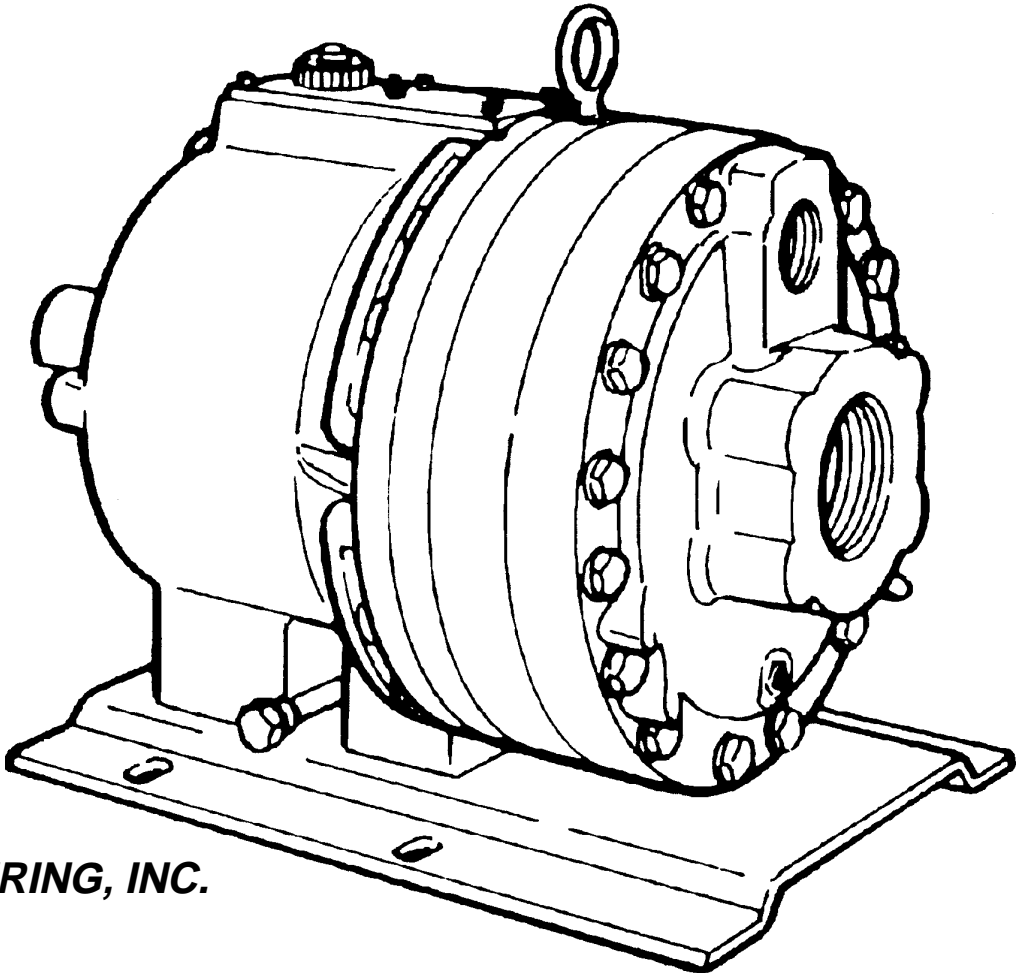

WANNER ENGINEERING, INC.

1204 Chestnut Avenue, Minneapolis, MN 55403
TEL: (612) 332-5681 FAX: (612) 332-6937
TOLL-FREE FAX [US only]: (800) 332-6812

www.hydra-cell.com
email: sales@wannereng.com
Document Fax Back System (510) 745-0440

D-35/G-35 Contents

	Page
Installation	2
Maintenance	6
Service (Fluid End)	7
Service (Hydraulic End)	11
Troubleshooting	14

D-35/G-35 Installation

NOTE: The numbers in parentheses are the Ref. Nos. on the illustrations in the Parts Manual.

Location

Locate the pump as close to the supply source as possible.

Install it in a lighted, clean space where it will be easy to inspect and maintain. Allow room for checking the oil level, changing the oil, and removing the pump head (manifold, valve plate, and related items).

Mounting

Do not exceed the maximum pump speed.

The pump shaft rotation is reversible.

To prevent vibration, mount the pump securely on a level rigid base.

On a belt-drive system, align the sheaves accurately: poor alignment wastes horsepower and shortens the belt and bearing life. Make sure the belts are properly tightened, as specified by the belt manufacturer.

On a direct-drive system, align the shafts accurately. Unless otherwise specified by the coupling manufacturer, maximum parallel misalignment should not exceed .015" and angular misalignment should be held to 1 degree maximum. Careful alignment extends life of the coupling, pump, shafts, and support bearings. Consult coupling manufacturer for exact alignment tolerances.

Important Precautions

Adequate Fluid Supply. To avoid cavitation and premature pump failure, be sure that the pump will have an adequate fluid supply and that the inlet line will not be obstructed. See "Inlet Piping".

Positive Displacement. This is a positive-displacement pump. To avoid severe system damage if the discharge line ever becomes blocked, install a relief valve downstream from the pump. See "Discharge Piping".

Safety Guards. Install adequate safety guards over all pulleys, belts, and couplings. Follow all codes and regulations regarding installation and operation of the pumping system.

Shut-Off Valves. Never install shut-off valves between the pump and discharge pressure regulator, or in the regulator bypass line.

Freezing Conditions. Protect the pump from freezing. See also the Maintenance Section.

Consult the Factory for the following situations:

- Extreme temperature applications (above 160° F or below 40° F)
- Pressure feeding of pumps
- Viscous or abrasive fluid applications
- Chemical compatibility problems
- Hot ambient temperatures (above 110° F)
- Conditions where pump oil may exceed 200° F because of a combination of hot ambient temperatures, hot fluid temperature, and full horsepower load — an oil cooler may be required

D-35/G-35 Installation

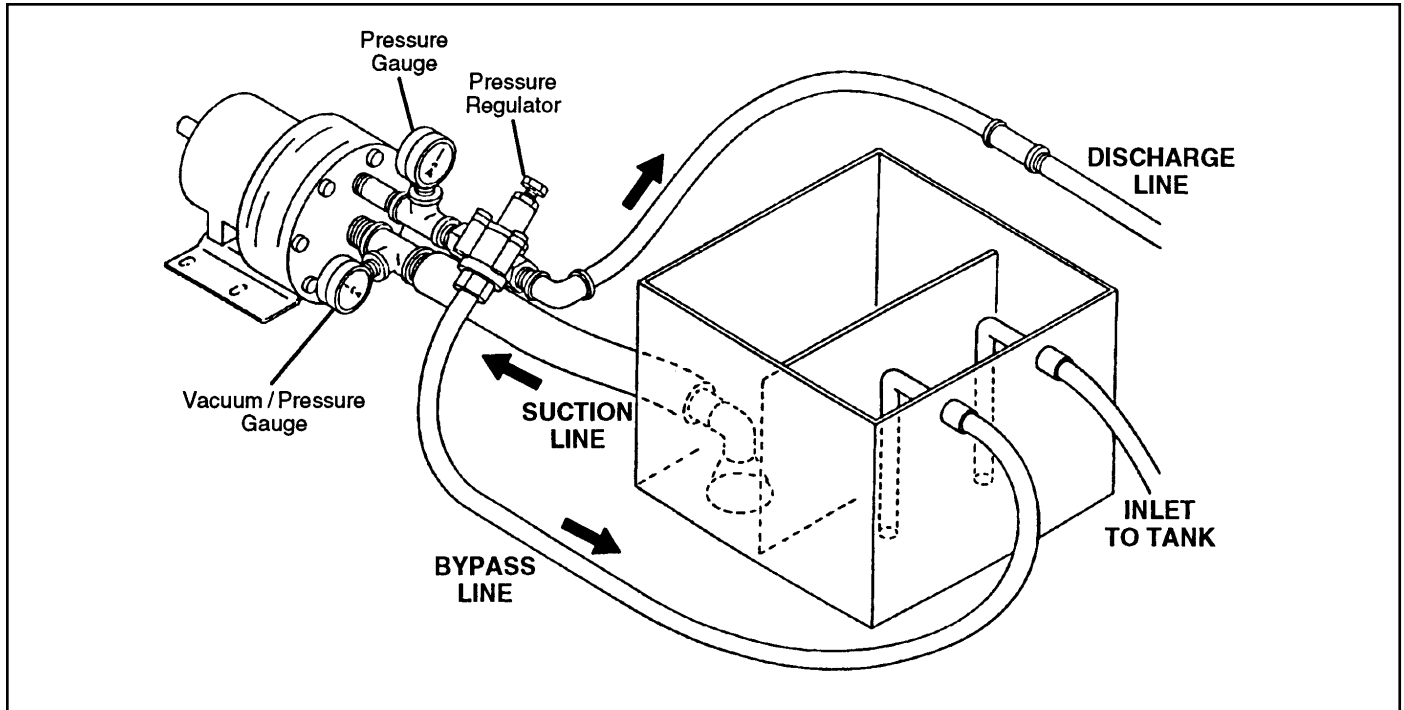

Inlet Piping (Suction Feed)

CAUTION: When pumping at temperatures above 140° F, use a pressure-feed system.

Install draincocks at any low points of the suction line, to permit draining in freezing conditions.

Provide for permanent or temporary installation of a vacuum gauge to monitor the inlet suction. Vacuum at the pump inlet should not exceed **7 in. Hg**. With Teflon® diaphragms, the inlet must be flooded.

Supply Tank

Use a supply tank that is large enough to provide time for any trapped air in the fluid to escape. The tank size should be at least twice the maximum pump flow rate.

Isolate the pump and motor stand from the supply tank, and support them separately.

Install a separate inlet line from the supply tank to each pump.

Install the inlet and bypass lines so they empty into the supply tank below the lowest water level, on the opposite side of the baffle from the pump suction line.

If a line strainer is used in the system, install it in the inlet line to the supply tank.

To reduce aeration and turbulence, install a completely submerged baffle plate to separate the incoming and outgoing liquids.

Install a vortex breaker in the supply tank, over the outlet port to the pump.

Place a cover over the supply tank, to prevent foreign objects from falling into it.

Hose and Routing

Size the suction line at least one size larger than the pump inlet, and so that the velocity will not exceed 1-3 ft/sec (0.3 to 0.9 m/s):

For pipe in inches: Velocity (ft/sec) = 0.408 x GPM/Pipe ID²

For pipe in mm: Velocity (m/sec) = 21.2 x LPM/Pipe ID²

Keep the suction line as short and direct as possible.

Use flexible hose and/or expansion joints to absorb vibration, expansion, or contraction.

If possible, keep the suction line level. Do not have any high points to collect vapor unless these high points are vented.

To reduce turbulence and resistance, do not use 90° elbows. If turns are necessary in the suction line, use 45° elbows or arrange sweeping curves in the flexible inlet hose.

If a block valve is used, be sure it is fully opened so that the flow to the pump is not restricted. The opening should be at least the same diameter as the inlet plumbing ID.

Do not use a line strainer or filter in the suction line unless regular maintenance is assured. If used, it should have a free-flow area of at least three times the free-flow area of the inlet.

Install piping supports where necessary to relieve strain on the inlet line and to minimize vibration.

Inlet Piping (Pressure Feed)

Provide for permanent or temporary installation of a vacuum/pressure gauge to monitor the inlet vacuum or pressure. Pressure at the pump inlet should not exceed 250 psi (17 bar); if it could get higher, install an inlet pressure reducing regulator.

Do **not** supply more than one pump from the same inlet line.

D-35/G-35 Installation

Inlet Calculations

Acceleration Head

Calculating the Acceleration Head

Use the following formula to calculate acceleration head losses. Subtract this figure from the NPSHa, and compare the result to the NPSHr of the Hydra-Cell pump.

$$H_a = (L \times V \times N \times C) \div (K \times G)$$

where:

H_a = Acceleration head (ft of liquid)

L = Actual length of suction line (ft) — not equivalent length

V = Velocity of liquid in suction line (ft/sec) [$V = \text{GPM} \times (0.408 \div \text{pipe ID}^2)$]

N = RPM of crankshaft

C = Constant determined by type of pump — use 0.04 for the D-35 and G-35 Hydra-Cell pumps

K = Constant to compensate for compressibility of the fluid — use:

1.4 for de-aerated or hot water

1.5 for most liquids

2.5 for hydrocarbons with high compressibility

G = Gravitational constant (32.2 ft/sec²)

Friction Losses

Calculating Friction Losses in Suction Piping

When following the above recommendations (under “inlet Piping”) for minimum hose/pipe I.D. and maximum length, frictional losses in the suction piping are negligible (i.e., $H_f = 0$) if you are pumping a water-like fluid.

When pumping more-viscous fluids such as lubricating oils, sealants, adhesives, syrups, varnishes, etc., frictional losses in the suction piping may become significant. As H_f increases, the available NPSH (NPSHa) will decrease, and cavitation will occur.

In general, frictional losses increase with increasing viscosity, increasing suction-line length, increasing pump flowrate, and decreasing suction-line diameter. Changes in suction-line diameter have the greatest impact on frictional losses: a 25% increase in suction-line diameter cuts losses by more than two times, and a 50% increase cuts losses by a factor of five times.

Consult the factory before pumping viscous fluids.

Minimizing Acceleration Head and Friction Losses

To minimize the acceleration head:

- Keep inlet lines less than 3 ft long
- Use at least 2 inch (50 mm) I.D. inlet hose
- Use soft hose (low-pressure hose, noncollapsing) for the inlet lines
- Minimize fittings (elbows, valves, tees, etc.)
- **Use a suction stabilizer on the inlet.**

Net Positive Suction Head

NPSHa must be equal to or greater than NPSHr. If not, the pressure in the pump inlet will be lower than the vapor pressure of the fluid— and cavitation will occur.

Calculating the NPSHa

Use the following formula to calculate the NPSHa:

$$\text{NPSHa} = P_t + H_z - H_f - H_a - P_{vp}$$

where:

P_t = Atmospheric pressure

H_z = Vertical distance from surface liquid to pump centerline (if liquid is below pump centerline, the H_z is negative)

H_f = Friction losses in suction piping

H_a = Acceleration head at pump suction

P_{vp} = Absolute vapor pressure of liquid at pumping temperature

NOTES:

— In good practice, NPSHa should be 2 ft greater than NPSHr

— All values must be expressed in feet of liquid

Atmospheric Pressure at Various Altitudes

Altitude (ft)	Pressure (ft of H ₂ O)
0	33.9
500	33.3
1000	32.8
1500	32.1
2000	31.5
5000	28.2

Discharge Piping

NOTE: Consult the Factory before manifolding two or more pumps together.

Hose and Routing

Use the shortest, most-direct route for the discharge line.

Select pipe or hose with a **working pressure** rating of at least 1.5 times the maximum system pressure. EXAMPLE: Select a 1500-psi W.P.-rated hose for systems to be operated at 1000-psi-gauge pressure.

Use about 6 ft (1.8 m) of flexible hose between the pump and rigid piping to absorb vibration, expansion or contraction.

Support the pump and piping independently. Size the discharge line so that the velocity of the fluid will not exceed 7-10 ft/sec (2-3 m/sec):

For pipe in inches: Velocity (ft/sec) = 0.408 x GPM/Pipe ID²

For pipe in mm: Velocity (m/sec) = 21.2 x LPM/Pipe ID²

D-35/G-35 Installation

Pressure Regulation

Install a pressure regulator or unloader in the discharge line. Bypass pressure must not exceed the pressure limit of the pump.

Size the regulator so that, when fully open, it will be large enough to relieve the full capacity of the pump without overpressurizing the system.

Locate the valve as close to the pump as possible and ahead of any other valves.

Adjust the pressure regulating valve to no more than 10% over the maximum working pressure of the system. Do not exceed the manufacturer's pressure rating for the pump or regulator.

Route the bypass line to the supply tank, or to the suction line as far as possible from the pump (to reduce the chance of turbulence).

If the pump will be operating for a long time with the discharge closed and fluid bypassing, install a thermal protector set to trip at 140° F in the bypass line (to prevent severe temperature buildup in the bypassed fluid).

CAUTION: Never install shutoff valves in the bypass line or between the pump and pressure regulator or relief valve.

Provide for permanent or temporary installation of a pressure gauge to monitor the discharge pressure at the pump.

For additional system protection, install a safety relief valve in the discharge line, downstream from the pressure regulator.

Before Initial Start-Up

Before you start the pump, be sure that:

- All shutoff valves are open, and the pump has an adequate supply of fluid.
- All connections are tight.
- The oil level is approximately 1 inch (2.5 cm) from the top of the fill port – so that the floor of the upper reservoir within the pump housing is flooded and the chamber itself is about 1/4 full, allowing for oil expansion as the pump runs and heats up.
- The relief valve on the outlet of the pump is adjusted so the pump starts under minimum pressure.
- All pulleys and belts are properly aligned, and belts are tensioned according to specification.
- All pulleys and belts have adequate safety guards.

Initial Start-Up Procedure

1. Turn on power to the pump motor.
2. Check the inlet pressure or vacuum. Inlet vacuum must not exceed 7 in. Hg at 70°F (180 mm Hg at 21°C). Inlet pressure must not exceed 250 psi (17 bar).
3. If you hear any erratic noise or if the flow is unsteady, refer to the Troubleshooting Section.
4. If the system has an air lock and the pump fails to prime:
 - a. Turn off the power
 - b. Remove the drain plug (1) on the bottom center of the manifold.
NOTE: Fluid may come out of this port when the plug is removed. Provide an adequate catch basin for fluid spillage, if required. Fluid will come out of this port when the pump is started, so we recommend that you attach adequate plumbing from this port so fluid will not be sprayed or lost. Use high-pressure-rated hose and fittings from this port. Take all safety precautions to assure safe handling of the fluid being pumped.
 - c. Jog the system on and off until the fluid coming from this port is air-free.
 - d. Turn off the power.
 - e. Remove the plumbing that was temporarily installed, and reinstall the drain plug (1).
5. Adjust the discharge pressure regulator to the desired operating and bypass pressures.
6. After the pressure regulator is adjusted, set the safety relief valve at 100 psi (7 bar) higher than the desired operating pressure. To verify this setting, adjust the discharge pressure regulator upward until the relief valve opens. Follow the recommendations in the above NOTE (step 4b) for handling the fluid that will come from the relief valve.
7. Reset the discharge pressure regulator to the desired system pressure.
8. Provide a return line from the relief valve to the supply tank, similar to the bypass line from the pressure regulator.

D-35/G-35 Maintenance

NOTE: The numbers in parentheses are the Reference Numbers on the exploded view illustrations found later in this manual and in the Parts Manual.

Daily

Check the oil level and the condition of the oil. The oil level is approximately 1 inch (2.5 cm) from the top of the fill port – so that the floor of the upper reservoir within the pump housing is flooded and the chamber itself is about 1/4 full, allowing for oil expansion as the pump runs and heats up.

Use the appropriate Hydra-Oil for the application (contact Wanner Engineering if in doubt).

CAUTION: If you are losing oil but don't see any external leakage, or if the oil becomes discolored and contaminated, one of the diaphragms (21) may be damaged. Refer to the Fluid-End Service Section. Do not operate the pump with a damaged diaphragm.

Periodically

Change the oil after the first 100 hours of operation, and every 1000 operating hours thereafter. When changing, remove the pipe cap (38) at the bottom of the pump so all oil and accumulated sediment will drain out.

CAUTION: Do not turn the drive shaft while the oil reservoir is empty.

Check the inlet pressure or vacuum periodically with a gauge.

Caution: Protect the pump from freezing.

Shutdown Procedure During Freezing Temperatures

Take all safety precautions to assure safe handling of the fluid being pumped. Provide adequate catch basins for fluid drainage and use appropriate plumbing from drain ports, etc. when flushing the pump and system with a compatible antifreeze.

1. Adjust the discharge pressure regulating valve so the pump runs under minimum pressure. Stop the pump.
2. Drain supply tank; open any draincocks in system piping and collect drainage; remove plug (1) from manifold and collect drainage.
3. Close draincocks in system piping and replace manifold plugs.
4. Fill supply tank with enough antifreeze to fill system piping and pump.

Note: disconnect the system return line from the supply tank and connect it to a separate reservoir.

5. Start the pump and allow it to run until the system is filled with antifreeze. Note: if the system has an airlock and the pump fails to prime, follow step 4 of the Initial Start-up Procedure to clear the air.
6. When mostly antifreeze is flowing from the system return line stop the pump. Connect the system return line back to the supply tank and circulate the antifreeze for a short period.
7. It is also good practice to change the oil in the Hydraulic End before storage for an extended period. This will remove any accumulated condensation and sediment from the oil reservoir. Drain and refill the Hydraulic End with the appropriate Hydra-Oil and operate the pump for a short period to assure smooth performance.

D-35/G-35 Service (Fluid End)

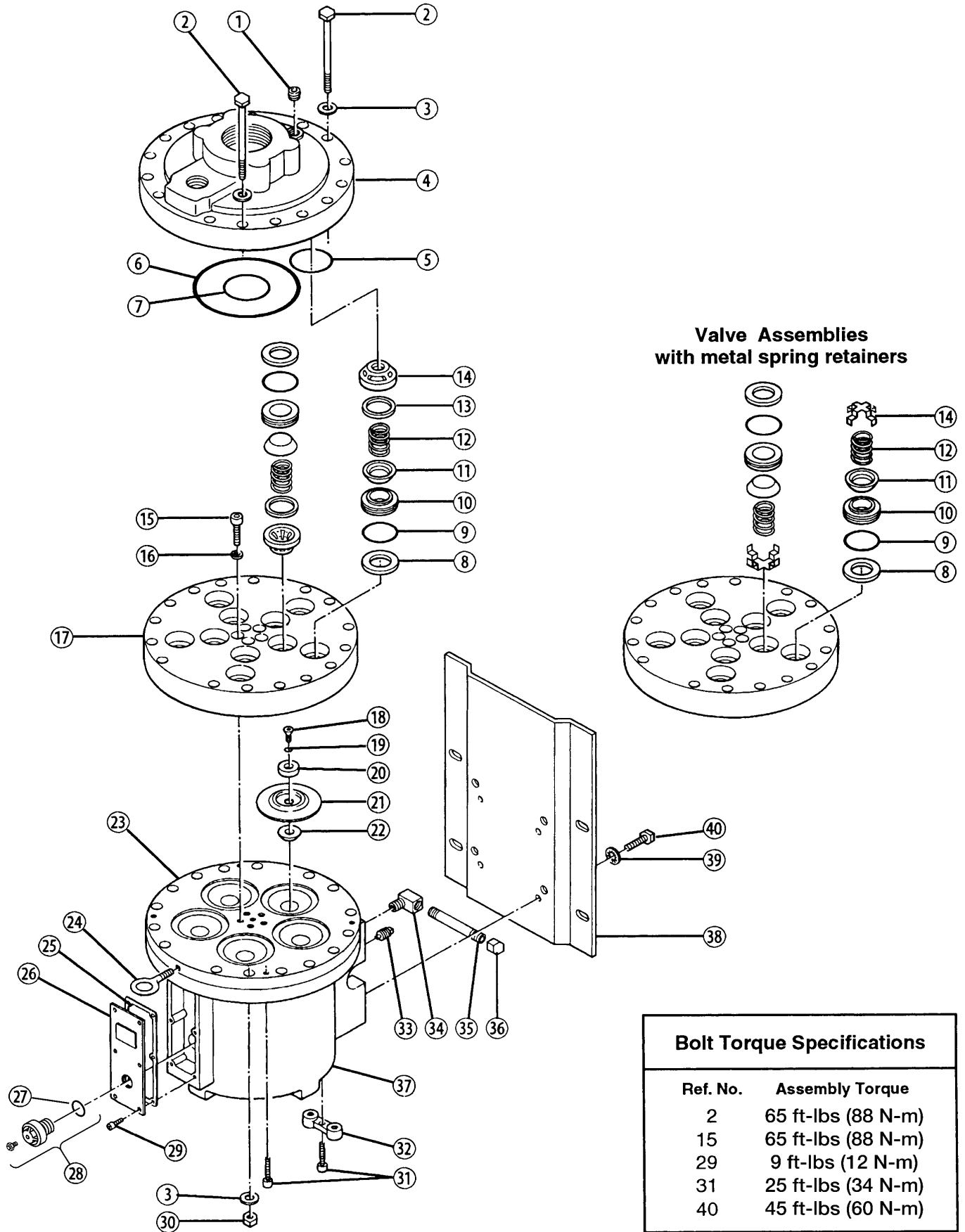

D-35/G-35 Service (Fluid End)

NOTE: The number in parentheses are the Reference numbers on the illustration on the preceding page and in the Parts Manual.

This section explains how to disassemble and inspect all easily-serviceable parts of the pump. Repair procedures for the hydraulic end (oil reservoir) of the pump are included in a later section of the manual.

CAUTION: Do not disassemble the hydraulic end unless you are a skilled mechanic. For assistance, contact Wanner Engineering (612-332-5681) or the distributor in your area.

CAUTION: Do not remove the four socket-head capscrews (31) that go through the back of the pump housing (37) and thread into the cylinder housing (23), unless you are repairing the hydraulic end of the pump.

Tools and Supplies

The following tools and supplies are recommended for servicing the fluid end of the pump:

- Wanner D-35 Tool Kit
- 18-mm hex socket
- 18-mm box-end wrench
- Two 19-mm open-end wrenches
- Large Phillips-head screwdriver
- Mallet
- Torque wrench to 70 ft-lbs (100 N-m)
- New oil
- Lubricating gel
- Fine emery cloth

The following additional supplies are recommended for servicing the hydraulic end of the pump:

- 17-mm hex socket or box-end wrench
- Grease
- Anaerobic seal sealant

Service Procedure

1. Remove Manifold and Valve Plate (4, 17)

- a. **Manifold.** Using an 18-mm hex socket and 18-mm box-end wrench, remove the 16 bolts (2) and hex nuts (30). **Do not remove** the four socket-head capscrews (31). Remove the manifold.

NOTE: When you remove the valve plate in the following step, some oil will leak out from behind the diaphragms. Provide something to catch this oil leakage.

- b. **Valve Plate.** Reinsert two of the perimeter bolts (2) through the pump housing from the shaft end at approximately the 2 and 10 o'clock positions, to hold the valve plate when the five capscrews (15) are removed. Using the 10-mm hex bit socket from the Wanner D-35 Tool Kit, remove the five socket-head capscrews and the valve plate.

CAUTION: Don't turn the pump drive shaft while the manifold and valve plate are off the pump, except when removing diaphragms or repriming the hydraulic cells.

- c. Inspect the manifold for warping or wear around the inlet and outlet ports. If wear is excessive, replace the manifold.
Inspect the valve plate in the same manner.

2. Inspect Valves (8-14)

NOTE: Wanner Valve Kits include items 8 - 14 and all O-rings for sealing the manifold to the valve plate.

The five inlet and five outlet valve assemblies are identical, but face in opposite directions. Inspect each valve as follows:

- a. Check the spring retainer (14), and replace if worn or damaged.
- b. Check the valve spring (12). If it is worn or shorter than a new spring, replace it. Don't just stretch the old spring.
- c. Check the valve (11) for wear or damage. If worn excessively, replace it.

NOTE: If your pump has plastic spring retainers, there is a Tetra seal (flat O-ring) (13) between the spring retainer (14) and valve seat (10). Pumps with metal spring retainers do not have the Tetra seal.

- d. Check the dampening washer (8), and replace if damaged.
- e. Remove the valve seat (10). A Seat Remover Tool is included in the Wanner D-35 Tool Kit. Be careful not to break the metal ridge around the O-ring groove. Inspect the valve seat for wear, and replace it if worn. Install a new O-ring (9).

NOTE: Whenever you replace any worn valve or valve seat, we recommend that you replace all the valve assemblies to ensure reliable operation. All the necessary parts are included in a replacement Valve Kit.

D-35/G-35 Service (Fluid End)

- f. Reinstall the valve assemblies:
 - Clean the valve ports and shoulders in the valve plate (17) with a Scotch-Brite™ pad or fine emery cloth. Wash the valve plate after cleaning, and lubricate the valve ports with a compatible grease, oil, or lubricating gel.
CAUTION: If the elastomers are EPDM material, do not use a petroleum-based lubricant on them. Instead, use an EPDM-compatible lubricant. If the product is food-grade, use a compatible food-grade lubricant.
 - Install the O-ring (9) on the valve seat (10), and lubricate it. Do this on all ten valve seats.
 - **Inlet Valves (five center valves).** Insert the spring retainer (14) into the valve plate (17), then insert the spring (12) into the spring retainer (14). If the pump has plastic spring retainers (14), insert the Tetra seal (13) between the retainer and valve seat (10). Insert the valve (11) on top of the valve spring (12), then insert the valve seat (10). The side of the seat that has the deepest chamfer should face the valve. Finally, insert the dampening washer (8). A compatible grease or oil will help the dampening washer to stick to the valve seat (10) for easier assembly.
 - **Outlet Valves (five outer valves).** Insert the dampening washer (8), valve seat (10), valve (11), and spring (12), then the spring retainer (14). If the pump has plastic retainers, install the Tetra seal (13) between the valve seat (10) and spring retainer (12).
 - **Slice in ridge of diaphragm.** Usually occurs when a diaphragm is operated at temperatures below its rated capability.
 - **Diaphragm edge chewed away.** Usually caused by overpressurizing the system. Could also be caused by the center and exterior bolts not being torqued to their correct values.
- e. Inspect the plunger (22) for any rough surfaces or edges. **Do not remove** the plunger from the valve plunger (69).
CAUTION: If a diaphragm was damaged and foreign material or water has entered the oil reservoir, do not operate the pump. Check all diaphragms, then flush the reservoir completely (as outlined below) and refill it with fresh oil. Never let the pump stand with foreign material or water in the reservoir, or with the reservoir empty.
- f. Install a new diaphragm (21) ridge-side out. We recommend that you not reuse old diaphragms, because the material may have taken a compression set and thus will not seal properly.
- g. Clean the screw (18), follower (20), and the threads in the valve plunger (69). Remove any oil from the valve plunger. Apply a medium-strength threadlocker (Loctite® 242) to the screw (18). Re-install the screw, O-ring (19), and follower, and tighten the screw to 18 in-lbs (200 N-cm).
- h. Repeat the above inspection and replacement procedure with the other four diaphragms.

3. Inspect and Replace Diaphragms (21)

- a. Lift the diaphragm by one edge, and turn the pump shaft until the diaphragm pulls up. This will expose machined cross-holes in the valve plunger (69) behind the diaphragm.
- b. Insert an Allen T-wrench (from the Wanner D-35 Tool Kit) through one of the cross-holes, to hold the diaphragm up.
- c. Holding the T-wrench so the valve plunger (69) won't rotate, remove the screw (18), O-ring (19), and follower (20) from the center of the diaphragm.
- d. Remove the diaphragm and inspect it carefully. A damaged diaphragm generally indicates a pumping system problem, and replacing only the diaphragm will not solve the larger problem. Inspect the diaphragm for the following:
 - **Half-moon marks.** Usually caused by cavitation of the pump (refer to "Troubleshooting", page 11).
 - **Concentric circular marks.** Usually caused by cavitation of the pump (refer to "Troubleshooting", page 11).
 - **Small puncture.** Usually caused by a sharp object in the fluid, or by an ice particle.
 - **Diaphragm pulled away** from the center screw or from the cylinder sides. Usually caused by fluid being frozen in the pump, or by overpressurization of the pump.

4. Flush Contaminate from Hydraulic End

(only if a diaphragm has ruptured)

- a. With the valve plate and manifold still removed (see above), remove the oil drain cap (38). Allow all oil and contaminate to drain out (catch and dispose of it properly).
- b. Fill the reservoir with kerosene or solvent, manually turn the pump shaft to circulate the kerosene, and drain. Catch and dispose of the contaminated fluid properly.
CAUTION: If you have EPDM diaphragms, or if food-grade oil is in the reservoir, do not use kerosene or solvents. Instead, flush with the same lubricant that is in the reservoir. Pumps with EPDM diaphragms have an "E" as the 7th digit of the Model No.
- c. Repeat the flushing procedure (step "b" above).
- d. Fill the reservoir with fresh oil, manually turn the pump shaft to circulate the oil, and drain once again. Catch the oil and dispose of it properly.
- e. Refill the reservoir. If the oil appears milky, there is still contaminate in the reservoir. Repeat the flushing procedure until the oil appears clean.

D-35/G-35 Service (Fluid End)

MODEL D-35 VALVE ASSEMBLIES

Valve Assembly with metal spring retainer

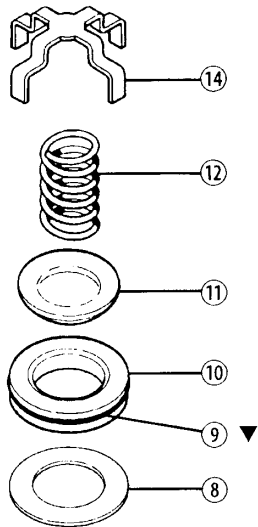

Valve Assembly with Celcon (plastic) spring retainer

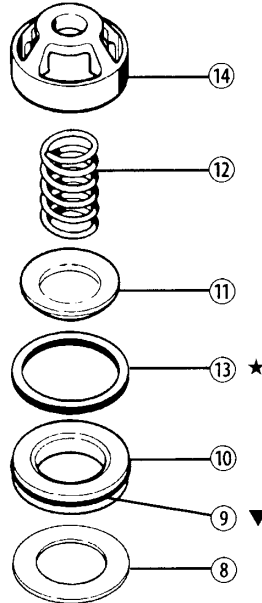

★ Tetra seal (13) is used only with plastic retainers.

▼ O-ring (9) is shown installed on valve seat (10).

5. Prime the Hydraulic Cells

- With the pump **horizontal and the fluid end head removed**, fill the reservoir with the appropriate Hydra oil for the application. Have a catch basin for oil that leaks from behind the diaphragms when priming. Catch the oil and dispose of it properly; **do not reuse it**.
- All air in the oil within the hydraulic cell (behind the diaphragm) must be forced out by turning the shaft (and thus pumping the piston). A Shaft Rotator is included in the Wanner D-35 Tool Kit. Rotate the shaft two revolutions and refill the reservoir. Rotate it two more revolutions and refill again. Continue to do this until the oil that is being pumped from the back of all five diaphragms is free of air.
- Wipe excess oil from the cylinder housing (23) and diaphragms.

6. Reinstall Valve Plate and Manifold (4, 17)

- Reinstall the valve plate (17), with the valve assemblies installed as outlined above, onto the cylinder housing (23).

- Insert two perimeter bolts (2) at the 10 and 2 o'clock positions, through the pump housing (39) from the shaft end, and then through the cylinder housing and valve plate. They will be used to hold the valve plate and manifold during reassembly.
- Place a lock washer (16) on each socket-head capscrew (15), and install all five centerbolts through the valve plate, then thread them into the cylinder housing. Before tightening these capscrews, install at least ten of the perimeter bolts (2) through the valve plate and cylinder housing holes, to make sure the alignment is good. Using a 10-mm hex socket and torque wrench, torque the five capscrews (15) to 65 ft-lbs (88 N-m). Then remove the ten perimeter bolts.
- Lubricate the O-rings (5-7) with petroleum jelly or lubricating gel to hold them in place. If this is a food-grade application or using EPDM elastomers, be sure the lubricating gel is compatible with the application. Install the O-rings in the grooves on the manifold (4).
- Reinstall the manifold onto the valve plate. Be sure the drain plug (1) is at the bottom of the manifold.
- Insert all 16 bolts (2), with washers (3) and hex nuts (32), around the edge of the manifold. Using an 18-mm hex socket and 18-mm box-end wrench, alternately tighten opposite bolts until all are secure. Torque to 65 ft-lbs (88 N-m).

D-35/G-35 Service (Hydraulic End)

Bolt Torque Specifications

Ref. #	Assembly Torque
56	25 ft-lbs (34 N-m)

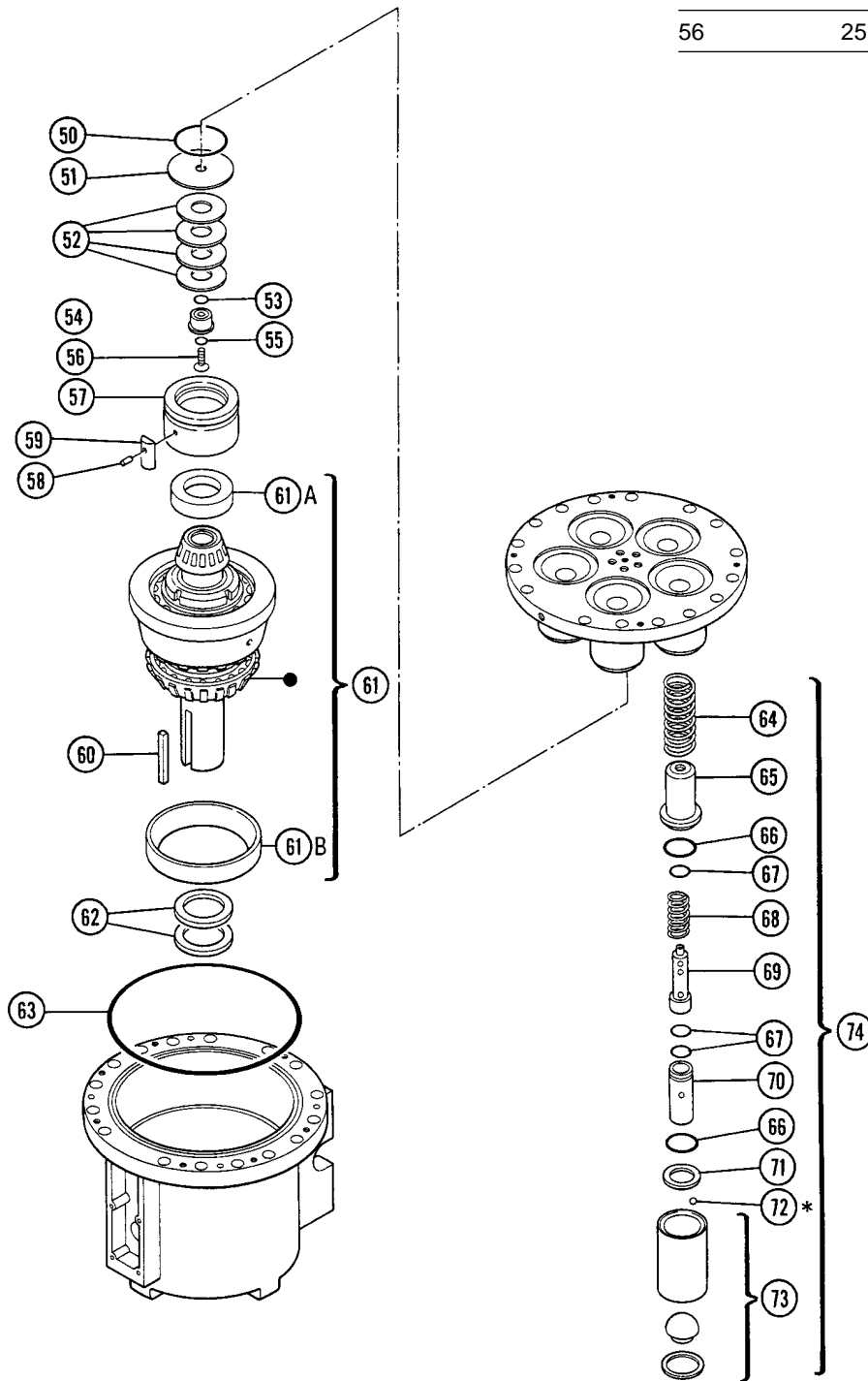

* Qty per piston: 4

D-35/G-35 Service (Hydraulic End)

NOTE: The number in parentheses are the Reference numbers on the illustration on the preceding page and in the Parts Manual.

This section explains how to disassemble and inspect the hydraulic end (oil reservoir) of the pump.

CAUTION: Do not disassemble the hydraulic end unless you are a skilled mechanic. For assistance, contact Wanner Engineering (612-332-5681) or the distributor in your area.

CAUTION: The four socket-head capscrews (31) that screw through the back of the pump housing (37) into the cylinder housing (23) hold these parts together. Do not remove these four screws except when repairing the hydraulic end.

NOTE: The following service procedures refer several times to the Wanner D-35 Tool Kit. We strongly urge you **not to try to repair** the hydraulic end of the pump without using the tools in this Kit (available from Wanner Engineering or your local distributor). Refer also to the list of tools and supplies in the Fluid-End Service Section.

Service Procedure

1. Remove Pump Housing

- Remove the manifold and valve plate, and the diaphragms, from the pump. Refer to the Fluid-End Service Section
- Drain the oil from the pump housing by removing the drain plug (36). Dispose of the oil properly.
- Check the shaft for sharp burrs. Smooth any burrs, to prevent scarring the seals (62) when removing the shaft.
- Reinsert two perimeter bolts (2) through the pump housing (37) and cylinder housing (23) from the shaft end, at the 10 and 2 o'clock positions, to support the parts as the pump is being disassembled.

Install the Shaft Rotator (from the Tool Kit) over the shaft. Push it on all the way, so the front of the Rotator touches the pump housing. Tighten the Rotator set screw into the keyway. This will keep the shaft assembly (61) attached to the pump housing (37) when the cylinder housing (23) is removed.

- Remove the four socket-head capscrews (31) that are threaded into the cylinder housing (23). Slide the cylinder housing out on the two bolts (2) that were inserted for support in Step d above. The preload on the piston return springs will push the cylinder housing out of the pump housing. Remove the cylinder housing assembly.
- Remove the shaft assembly (61) by loosening the set screw in the Shaft Rotator and sliding the shaft out of the seals (59). The parts are heavy and you may need a second person or a lifting device to move some of them.
- Remove the bearing adjustment plate (57) and inspect the bearing cup (61B) from the cylinder housing (23). Inspect all parts for wear, and replace if necessary.
- Inspect the cam and bearings (61), and the bearing cup (61B) in the housing. If the bearings are pitted or binding, or if the bearing cup in the housing is worn, contact Wanner Engineering.

CAUTION: If a bearing cup or bearing cone is replaced, they must be replaced as a pair or premature failure will result.

2. Disassemble Pistons

- Place the cylinder housing assembly (23) on a clean flat surface, with the piston-fee side down.
- With the diaphragms removed (see the Fluid-End Service Section), thread a follower screw (18) approximately three turns into one of the valve plungers (69). Tap the follower screw lightly with a hammer, and the plunger (22) should slip off the valve plunger (69). Remove the follower screw, and the hydraulic piston assembly (74) can then be removed. Repeat this for all five cylinders.
- Inspect and clean all parts of the hydraulic piston assembly (74), and replace all O-rings and any other parts that are worn or damaged. Repeat this on all five assemblies.

3. Reassemble Pistons

NOTE: When reassembling the hydraulic pistons, use new plungers (22). They are press-fit onto the valve plungers (69) and are not reusable.

- Drop a ball (72) into each opening in the bottom of the piston assembly (73).
NOTE: Using grease on the O-rings, and lubricating the parts, will aid in assembly.
- Insert a retaining washer (71) and O-ring (66) to hold the balls in place.
- Insert a valve plunger (69) into the valve cylinder (70). Slide a spring (68) over the valve plunger (69), inside the valve cylinder (70).
- Insert an O-ring (67) into the spring retainer (65).
- Install two O-rings (67) onto the valve cylinder (70).
- Install an O-ring (66) onto the spring retainer (65).
- Slide the assembled valve cylinder (70), valve plunger (69), and spring (68) into the spring retainer (65).
- Slide the complete cylinder-and-retainer assembly into the piston assembly.
- Insert a piston return spring (64) into the piston assembly.
- Repeat the above procedure for the other four pistons.

4. Remove Shaft Seals (62)

Inspect the shaft seals (62) before continuing. If they look damaged in any way, replace them. Remove by pounding them out from inside the pump housing. Replace both shaft seals at the same time. Clean the bore in the housing using emery cloth or Scotch-Brite™.

D-35/G-35 Service (Hydraulic End)

5. Reassemble Pump Housing, Shaft Assembly, and Cylinder Housing

- a. With the pump housing horizontal and mounted on the baseplate, insert the cam assembly (61) into the pump housing. If the shaft seals (62) are still in the pump housing (37), wrap the shaft with the Seal Protector Bag (from the D-35 Tool Kit). Grease the bag and slide it through the seals, then remove the bag.

Place the Shaft Rotator (from the Tool Kit) over the end of the shaft and slide it up tight against the pump housing. Keep the cam assembly (61) tight against the pump housing bearing, and horizontal, and tighten the Shaft Rotator set screw to the shaft keyway. This will hold the cam assembly horizontal and aid in assembly.

- b. Install the O-ring (63) onto the pump housing. Use grease to aid in holding the O-ring.
- c. Place the cylinder housing (23) face-down on a clean surface.
- d. Insert the bearing adjustment plate (57), with the bearing cup (61A), dowel pin (58), and key (59), into the cylinder housing (23).
- e. Insert the five piston assemblies into the cylinder housing.
- f. To aid in assembly, insert two perimeter bolts (2) through the pump housing from the shaft side, at the 10 and 2 o'clock positions.
- g. Pick up the cylinder housing assembly and slide it onto the two bolts (2) that are in the pump housing. It will slide on until the piston feet contact the cam. Insert up to eight more bolts (2) through the pump housing and cylinder housing to aid in alignment.
- h. Using a 17-mm hex socket or box-end wrench, install the four 10-mm x 100-mm fully-threaded bolts (from the Tool Kit) through the pump housing where the four socket-head capscrews (31) were fastened. Tighten these four bolts evenly, and the cylinder housing assembly should pull itself tight against the pump housing.
One at a time, remove the fully-threaded bolts and replace them with the capscrews (31). Tighten all four capscrews to 25 ft-lbs (34 N-m).
- i. Remove the Shaft Rotator that was installed on the shaft to aid in assembly.

6. Install Shaft Seals (59)

- a. Wrap the shaft with the Seal Protector Bag (from the D-35 Tool Kit). Grease the bag and slide on one seal (62) up to the pump housing.

Pack the inside (spring side) of the second seal half-full with grease. Slide this seal on and flush against the first seal. Make sure the outside diameters of the two seals are clean and free of grease. Remove the protector bag by sliding it off the shaft.

- b. Apply an anaerobic seal sealant or bearing retaining compound (such as Loctite® 601 or 609) to the outside diameter of the seals.

Install the Shaft Rotator/Seal Inserter (from the D-35 Tool Kit) over the shaft. Using a mallet, tap the tool to push the two seals into the pump housing. Wipe off excess sealant.

7. Reinstall Plungers (22)

NOTE: If the plungers (22) have been removed from the valve plungers (69), do not reuse them. Install new ones instead.

- a. Place a plunger (22) onto the exposed screw end of the Plunger Guide Tool (from the D-35 Tool Kit). The flat side of the plunger should face the tool.
- b. Screw the Guide Tool (with the plunger) into the valve plunger (69) until tight.
- c. Pull the valve plunger up until its cross holes are exposed. Insert the Allen T-Wrench (from the D-35 Tool Kit) or a similar dowel-type object through the top cross hole.
- d. Hold the hex bolt with a 19-mm wrench. At the same time, hold the Allen T-wrench and tighten the hex nut against the plunger (22) with another 19-mm wrench. This will press the plunger onto the valve plunger (69).
- e. Remove the Plunger Guide Tool.
- f. **Before** you remove the Allen T-Wrench, install a new diaphragm. See "Reinstall Diaphragms" below.
- g. Repeat the procedure on the other four cylinders.

8. Reinstall Diaphragms (21)

NOTE: Keep the Allen T-Wrench through the valve plunger (69), as described above under "Reinstall Plungers".

- a. Place the diaphragm (21) onto the plunger (22), ridge side out.
- b. Center the follower (20) on the diaphragm.
- c. Place the O-ring (19) onto the follower screw (18).
- d. Apply a small amount of threadlocker (e.g., Loctite 242) to the threads of the follower screw (18).
- e. Insert the follower screw (18), with its O-ring (19), through the follower (20) and diaphragm (21). Then screw it into the valve plunger (69).
- f. Hold the Allen T-Wrench and tighten the follower screw (18) to 18 in-lbs (200 N-m).
- g. Repeat the above procedure for the other four cylinders.
- h. Fill the reservoir with fresh oil and prime the pump, as outlined in the Fluid-End Service Section.

D-35/G-35 Troubleshooting

Cavitation

- Inadequate fluid supply because:
 - Inlet line collapsed or clogged
 - Clogged line strainer
 - Inlet line too small or too long
 - Air leak in inlet line
 - Worn or damaged inlet hose
 - Suction line too long
 - Too many valves and elbows in inlet line
 - NPSHa is less than NPSHr
- Fluid too hot for inlet suction piping system.
- Air entrained in fluid piping system.
- Aeration and turbulence in supply tank.
- Inlet vacuum too high

Symptoms of Cavitation

- Excessive pump valve noise
- Premature failure of spring or retainer
- Volume or pressure drop
- Rough-running pump

Drop in Volume or Pressure

A drop in volume or pressure can be caused by one or more of the following:

- Air leak in suction piping
- Clogged suction line or suction strainer
- Suction line inlet above fluid level in tank
- Inadequate fluid supply
- Pump not operating at proper RPM
- Relief valve bypassing fluid
- Worn pump valve parts
- Foreign material in inlet or outlet valves
- Loss of oil prime in cells because of low oil level
- Ruptured diaphragm
- Cavitation
- Warped manifold from overpressurized system
- O-rings forced out of their grooves from overpressurization
- Air leak in suction line strainer or gasket
- Cracked suction hose.
- Empty supply tank
- Excessive aeration and turbulence in supply tank
- Worn and slipping drive belt(s)
- Worn spray nozzle(s)

Pump Runs Rough

- Worn pump valves
- Airlock in outlet system
- Oil level low
- Wrong weight of oil for cold operating temperatures (change to lighter weight)
- Cavitation
- Air in suction line
- Restriction in inlet/suction line
- Hydraulic cells not primed after changing diaphragm
- Foreign material in inlet or outlet valve
- Damaged diaphragm
- Fatigued or broken valve spring

Premature Failure of Diaphragm

- Frozen pump
- Puncture by a foreign object
- Elastomer incompatible with fluid being pumped
- Pump running too fast
- Excess pressure

Water (or Process Fluid) in Oil Reservoir

- Condensation
- Ruptured diaphragm
- Hydraulic cell not properly primed after diaphragm replacement
- Frozen pump

Water (or Process Fluid) Pulsations

NOTE: Small pulsations are normal in single-acting pumps with multiple pumping chambers.

- Foreign object lodged in pump valve
- Loss of prime in hydraulic cell because of low oil level
- Air in suction line
- Valve spring (13) broken
- Cavitation
- Aeration or turbulence in supply tank

D-35/G-35 Troubleshooting

Valve Wear

- Normal wear from high-speed operation
- Cavitation
- Abrasives in the fluid
- Valve incompatible with corrosives in the fluid
- Pump running too fast

Loss of Oil

- External seepage
- Rupture of diaphragm
- Frozen pump
- Worn shaft seal
- Oil drain piping or fill cap loose.
- Valve plate and manifold bolts loose

Premature Failure of Valve Spring or Retainer

- Cavitation
- Foreign object in the pump
- Pump running too fast
- Spring/retainer material incompatible with fluid being pumped

Limited Warranty

Wanner Engineering, Inc. extends to the original purchaser of equipment manufactured by it and bearing its name, a limited one-year warranty from the date of purchase against defects in material or workmanship, provided that the equipment is installed and operated in accordance with the recommendations and instructions of Wanner Engineering, Inc. Wanner Engineering, Inc. will repair or replace, at its option, defective parts without charge if such parts are returned with transportation charges prepaid to Wanner Engineering, Inc., 1204 Chestnut Avenue, Minneapolis, Minnesota 55403.

This warranty does not cover:

1. The electric motors (if any), which are covered by the separate warranties of the manufacturers of these components.
2. Normal wear and/or damage caused by or related to abrasion, corrosion, abuse, negligence, accident, faulty installation or tampering in a manner which impairs normal operation.
3. Transportation costs.

This limited warranty is exclusive, and is in lieu of any other warranties (express or implied) including warranty of merchantability or warranty of fitness for a particular purpose and of any noncontractual liabilities including product liabilities based on negligence or strict liability. Every form of liability for direct, special, incidental or consequential damages or loss is expressly excluded and denied.



WANNER ENGINEERING, INC.

1204 Chestnut Avenue, Minneapolis, MN 55403
TEL: (612) 332-5681 FAX: (612) 332-6937
TOLL-FREE FAX [US only]: (800) 332-6812

www.hydra-cell.com
email: sales@wannereng.com
Document Fax Back System (510) 745-0440

D35-991-2400 Rev. C

©2001 Wanner Engineering, Inc. Printed in USA 05-01