

D-10 Series

Up to 8 gpm (30 l/min)

D-10 Specialized Designs



Hydra-Cell Slurry Duty pumps are specifically designed for abrasive slurry applications. See page 72 for complete specifications.



The D-10 Hydra-Cell can be equipped with welded flange pump heads for critical performance applications such as oil/gas installations and chemical process facilities. See page 50.



The D-10 Hydra-Cell is available with a motor adaptor flange for shaft coupler mounting to industry standard sized motor frames. See page 50.

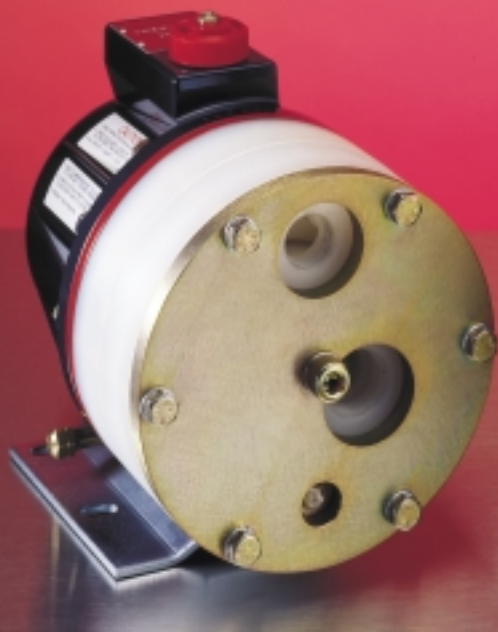

D-10 with polypropylene pump head



D-10 with brass pump head

Hydra-Cell[®]
SIMPLY BUILT TO LAST

D-10 Series Performance

flow

model	max flow		max input rpm
	gpm	l/min	
D-10-X	8	30.3	1450
D-10-E	8	30.3	1750
D-10-S	6	22.7	1750
D-10-I	4	15.1	1750
D-10-X	5.4	20.4	1150
D-10-E	5.4	20.4	1150
D-10-S	4.1	15.5	1150
D-10-I	2.8	10.6	1150

pressure

Maximum Inlet Pressure:

250 psi (17.3 bar)

Pressure Variable To:

Metallic Heads: 1000 psi (69 bar)

Non-Metallic Heads: 250 psi (17.3 bar)

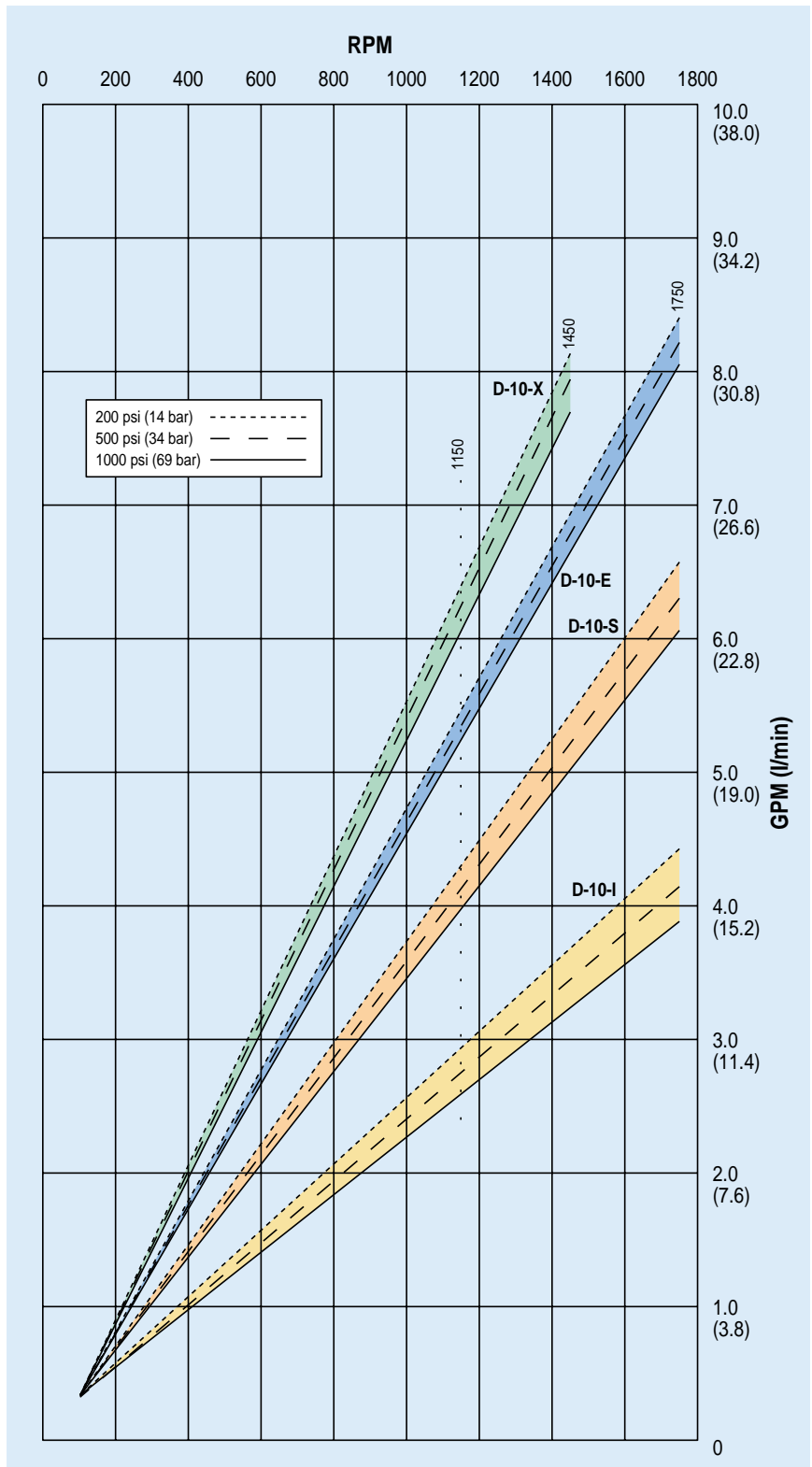

D-10 Series Specifications

Maximum Capacity

	rpm	gpm	l/min
D-10-X	1450	8	30.3
D-10-E	1750	8	30.3
D-10-S	1750	6	22.7
D-10-I	1750	4	15.1

Delivery @ max pressure

	revs/gal	revs/liter
D-10-X	185	49
D-10-E	219	58
D-10-S	292	78
D-10-I	437	115

Max Inlet Pressure 250 psi (17.3 bar)

Pressure Variable to Metallic Head: 1000 psi (69 bar)
Non-Metallic Head: 250 psi (17.3 bar)

Max Temperature 250°F (refer to engineering section, page 94 for temperatures above 180°F)

Inlet Port 1 inch NPT

Discharge Port 3/4 inch NPT

Shaft Diameter 7/8 inch

Shaft Rotation Bi-directional

Bearings Tapered roller bearings

Oil Capacity 1.1 US quart (1.05 liters), see page 88 for oil selection and specification.

Weight

Metallic Heads: 48 lbs (21.8 kg)

Non-Metallic Heads: 35 lbs (15.9 kg)

Calculating Required Horsepower

$$\frac{15 \times \text{rpm}}{63,000} + \frac{\text{gpm} \times \text{psi}}{1,460} = \text{electric motor HP}$$

For installation guidelines and other pump selection design considerations, refer to pages 92-95.

Net Positive Suction Head (NPSHr)

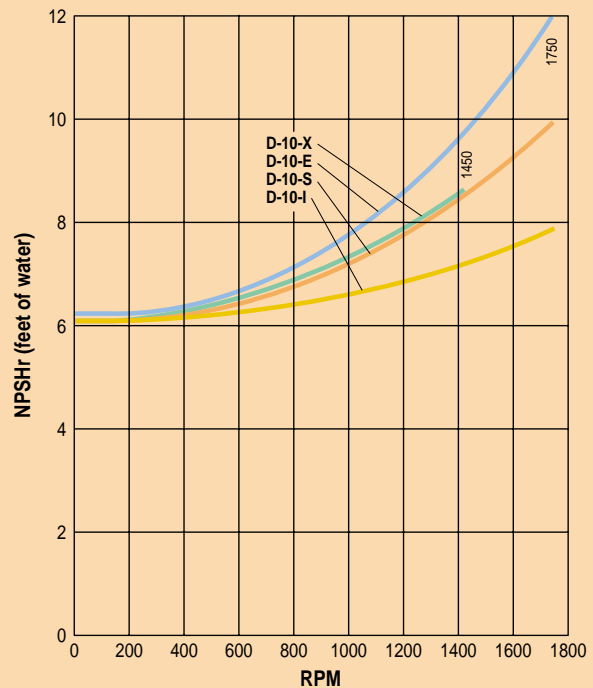

Dry Lift

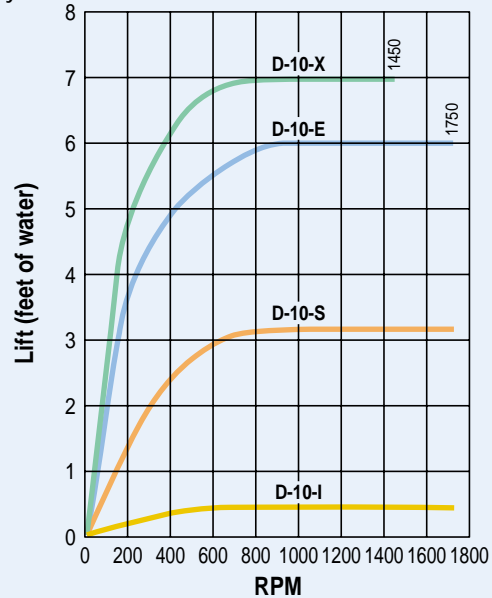

D-10 Series Dimensions

D-10 Models with Metallic Pumping Head

Brass
Cast Iron
316 Stainless Steel
Nickel Alloy (C Series)

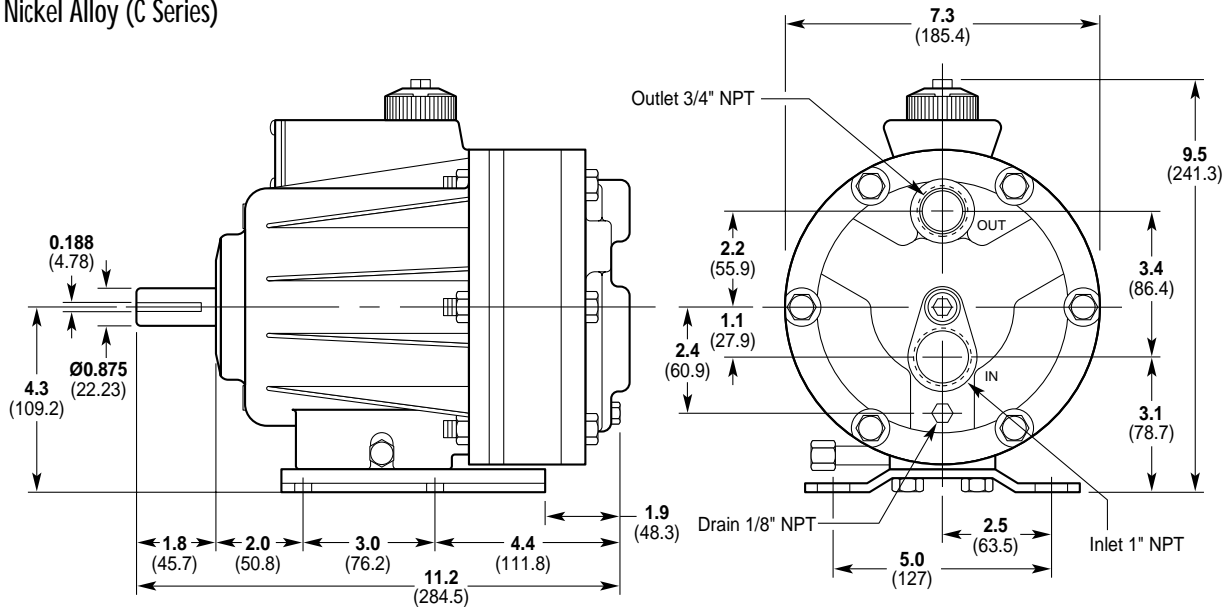

D-10 Models with Non-metallic Pump Head

Kynar®
Polypropylene

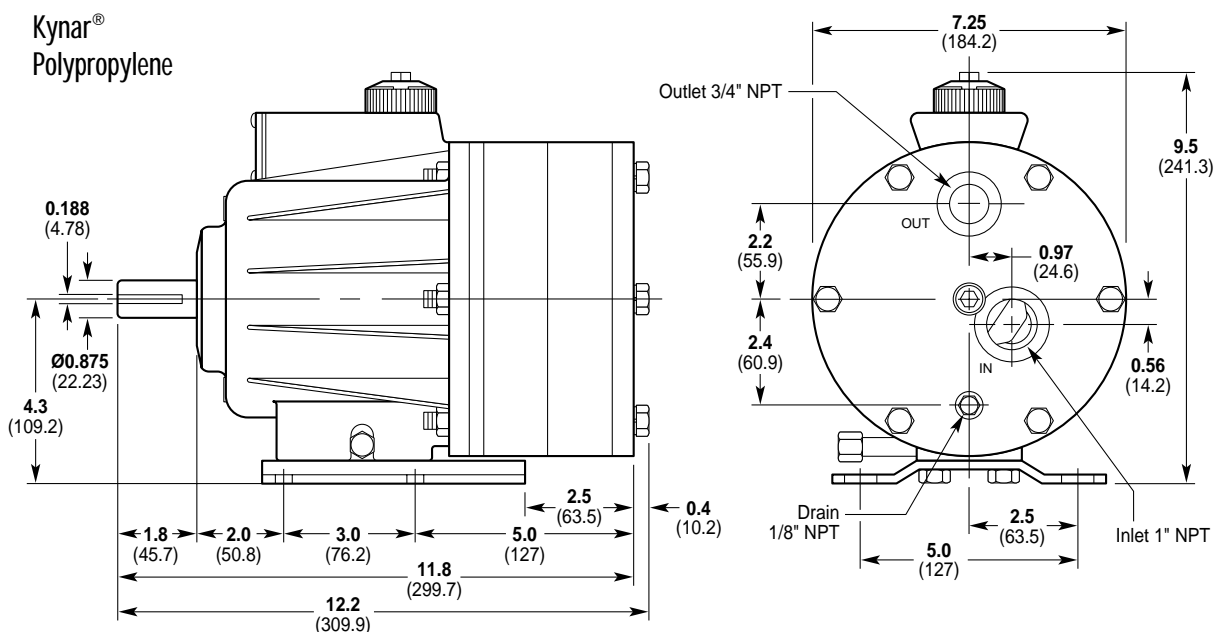

D-10 Series Options

Materials of Construction

D-10 Hydra-Cell pumps are manufactured in a variety of heavy-duty materials to meet specific pumping needs. Refer to the design section for more information on appropriate material selection and chemical compatibility. Other customized materials are available by special order. Contact factory application engineering department for further information.



Pumping Head
 316 Stainless Steel
 Brass
 Cast Iron
 Kynar®
 Nickel Alloy (Hastelloy Remelt, CMW12D)
 Polypropylene



Valves
 17-4 PH Stainless Steel
 17-7 PH Stainless Steel
 Ceramic
 Hastelloy® C
 Nitronic 50



Diaphragms & O-rings
 Buna-N
 Buna-N-XS
 EPDM
 Neoprene
 Teflon®
 Viton®
 Viton®-XT



Valve Springs
 17-7 PH Stainless Steel
 Elgiloy®
 Hastelloy® C



Valve Seats
 17-4 PH Stainless Steel
 316 Stainless Steel
 Ceramic
 Hastelloy®



Valve Spring Retainers
 17-7 PH Stainless Steel
 Celcon®
 Hastelloy® C
 Kynar®
 Nylon (Zytel®)
 Polypropylene

D-10 Series Accessories

Options, Accessories and Custom Designs

- Valves, page 78
- Hydra-Oil, page 88
- Couplers, page 87
- Hose Connectors, page 87
- Tool Kits, page 90

Welded Flange Pump Heads

The D-10 Hydra-Cell can be equipped with welded flange pump heads for critical performance applications such as oil/gas installations and chemical process facilities.

Design Features

- 316 stainless steel flanges
- Ductile iron pump housing
- 1" ANSI pipe flange inlet; 3/4" ANSI pipe flange outlet

Ordering Information

Contact factory for complete specifications and ordering information.

Pump/Motor Adapters

A04-001-1200

For:
 56C
 143TC
 145TC
 frame motors

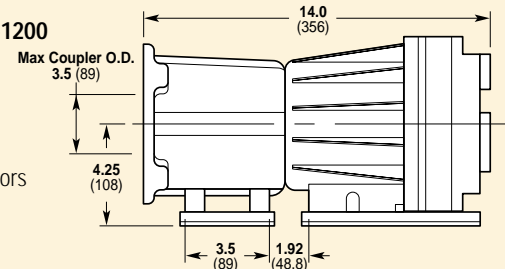

A04-002-1200

For:
 182TC
 184TC
 213TC
 215TC
 frame motors

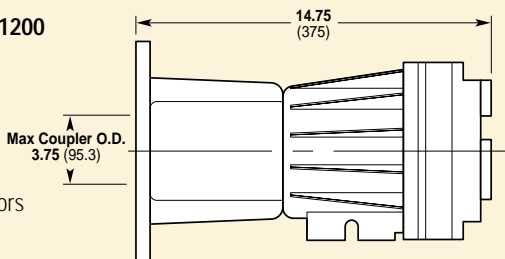

D-10 Series How To Order

Ordering Information

A complete D-10 Series Model Number contains 12 digits including 8 customer-specified design options: for example D10XLBNHFCA.

1	2	3	4	5	6	7	8	9	10	11	12
D	1	0		L							

4 Hydraulic End Cam

- X Max 8 gpm (32.2 lpm) @ 1450 rpm
- E Max 8 gpm (30.3 lpm) @ 1750 rpm
- S Max 6 gpm (22.7 lpm) @ 1750 rpm
- I Max 4 gpm (15.1 lpm) @ 1750 rpm

6 Pumping Head Material

- B Brass
- C Cast Iron (nickel plated)
- M Kynar® (with Hastelloy® C followers & follower screws)
- N Polypropylene (with Hastelloy® C followers & follower screws)
- P Polypropylene (with 316 stainless steel followers & follower screws)
- S 316 Stainless Steel
- T Nickel Alloy (Hastelloy Remelt, CMW12D)

7 Diaphragm & O-ring Material

- E EPDM (requires order code C or D-30 or 40 wt EPDM-compatible oil)
- G Viton®-XT
- J Teflon® (available with E and S cams only; 1200 rpm max; cannot be used with non-metallic heads)
- N Buna-N
- P Neoprene
- T Buna-N-XS
- V Viton®

8 Valve Seat Material

- C Ceramic
- H 17-4 PH Stainless Steel
- S 316 Stainless Steel
- T Hastelloy® C

9 Valve Material

- C Ceramic
- F 17-4 PH Stainless Steel (machined)
- H 17-7 PH Stainless Steel (stamped)
- N Nitronic 50
- T Hastelloy® C

10 Valve Springs

- E Elgiloy®
- H 17-7 PH Stainless Steel
- T Hastelloy® C

11 Valve Spring Retainers

- C Celcon
- H 17-7 PH Stainless Steel
- M Kynar®
- P Polypropylene
- T Hastelloy® C
- Y Nylon (Zytel)

12 Hydra-Oil

- A 10W30 (standard)
- B 40-wt for continuous-duty (use with 316 SST or Hastelloy pump head (standard))
- C 30-wt EPDM-compatible oil
- D 40-wt high-temp EPDM-compatible oil
- E 30-wt food-contact oil
- F 40-wt high-temp food-contact oil
- G 5W30 cold-temp severe duty oil
- H 15W50 high-temp severe-duty synthetic oil