

# Super Flow From Superior Pumps

**H**aight Pump is proud to introduce our newest addition. The “Universeal” design has been extended to handle flow rates from 120 gpm to 400 gpm! Flexible, quick, and incredibly reliable- Haight’s Ductile Iron Unniversal Series Pumps are superior to the rest!

10 sizes ranging from 120gpm to 400 gpm

UniverSeal built in shaft seal flexibility

Broad range of field changeable seals

Close coupled design eliminates shaft misalignment related failures

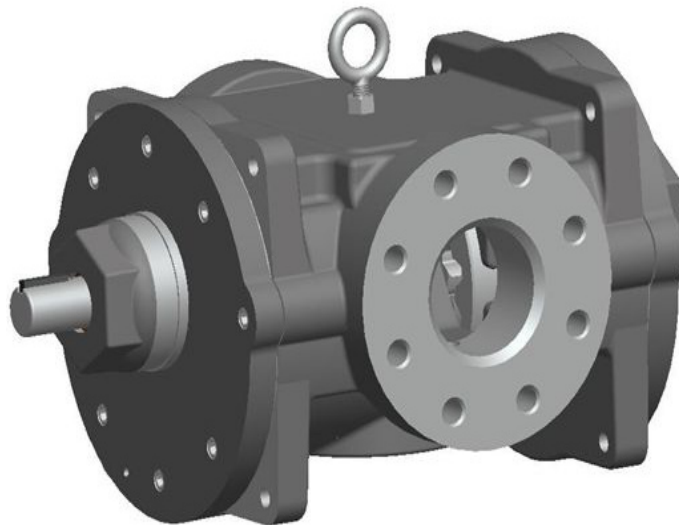

3 inch NPT ports in 120-240 gpm

4 inch NPT ports in 250-400 gpm

Only two moving parts reduces wear

“Gear within a Gear” design for quiet operation

Standard construction features a ductile iron housing, steel shaft and pinion gears, iron rotor and bearings, with a Buna N lip seal and elastomers. Alternate shaft seal and elastomer options include Neoprene, Silicone, and Teflon.

Application possibilities include: Petroleum products, Lubrication systems, Food processing, Soap and detergent products, Paper products, Shipbuilding, and Mining, among many others.

**HAIGHT**® **PUMPS**  
DIVISION OF: BAKER MANUFACTURING CO., LLC

*Large  
Pumps that Perform*

Contact us: 800-871-9250P 608-882-3777F  
[www.haightpump.com](http://www.haightpump.com)