

| REV. | DESCRIPTION | BY | APP. | DATE |
|------|------------------------------|------|------|------|
| A | 4 x 3 - 8G A70 ANSI ASSEMBLY | M.H. | | |

NOTES: UNLESS OTHERWISE SPECIFIED

1. DIMENSIONS AND TOLERANCES PER ANSI Y14.5M-1982.
2. * INDICATES DIMENSIONS AND/OR FEATURES MODIFIED ON CURRENT REVISION LEVEL.

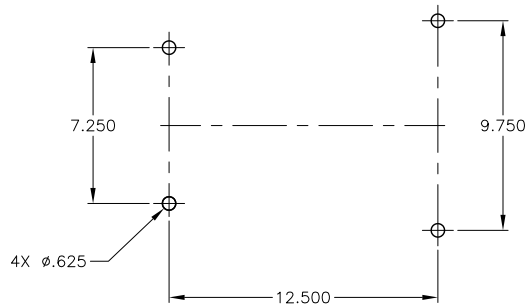
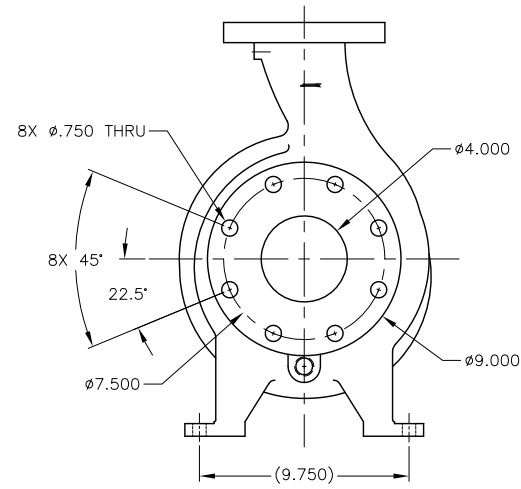
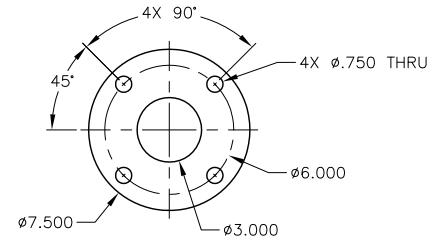
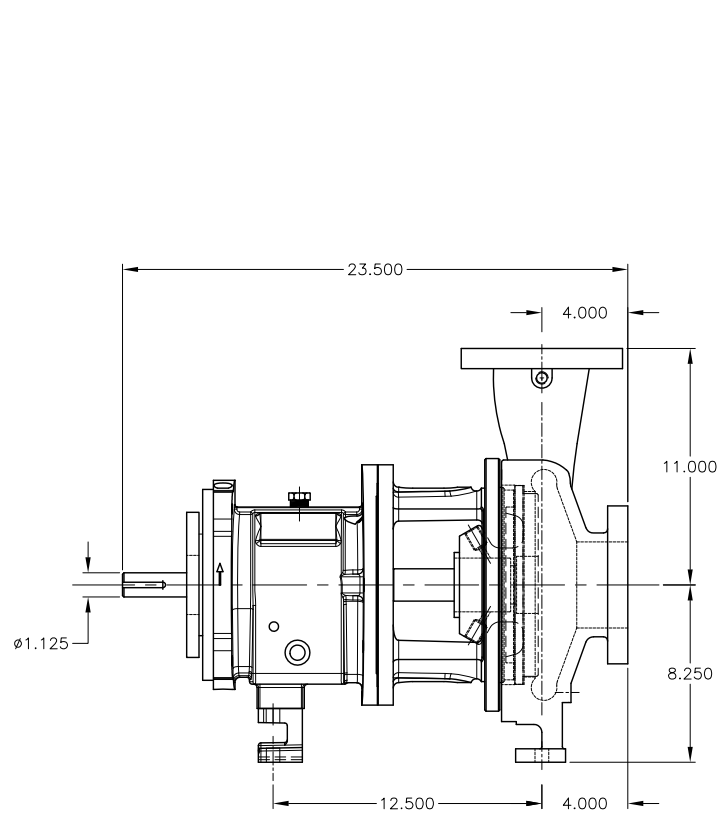

| | |
|-----------------------------|--------|
| DO NOT SCALE DRAWING | |
| UNLESS OTHERWISE SPECIFIED | |
| DIMENSIONS ARE IN INCHES | |
| TOLERANCES ARE: | |
| FRACTIONS | ± - |
| DECIMALS .XX | ± - |
| .XXX | ± - |
| ANGLES | ± - |
| SCALE | 1/1 |
| SHEET | 1 OF 1 |



GRISWOLD PUMP COMPANY
 22080 15th STREET ST.
 GRAND TERRACE, CA 92313
 PHONE: (800) 843-2223, FAX: (800) 752-2929

| | | | |
|-------------|----------|-------------------------------|----------|
| TITLE | | ASSEMBLY, 4 X 3 - 8G A70 ANSI | |
| DRAWN BY | M. HIATT | DATE | 03/22/09 |
| CHECKED BY | | DATE | |
| APPROVED BY | | DATE | |
| ASSY. NO. | | DRAWING NO. | 438GA70 |
| REV. | | | A |

THIS DOCUMENT AND ITS CONTENTS ARE PROPRIETARY TO WILSON PUMP AND ENGINEERING CO. ANY REPRODUCTION, DISCLOSURE OR USE OF THIS DOCUMENT IS EXPRESSLY PROHIBITED EXCEPT AS OTHERWISE AGREED TO IN WRITING.