

Mini Bellows *Pumps*

Mini bellows models are ideal for low flow, low pressure metering applications. The pump is constructed entirely of plastic and utilizes GRI's time-proven bellows technology to provide an accurate chemically-resistant metering pump with a long life, at an economical price.

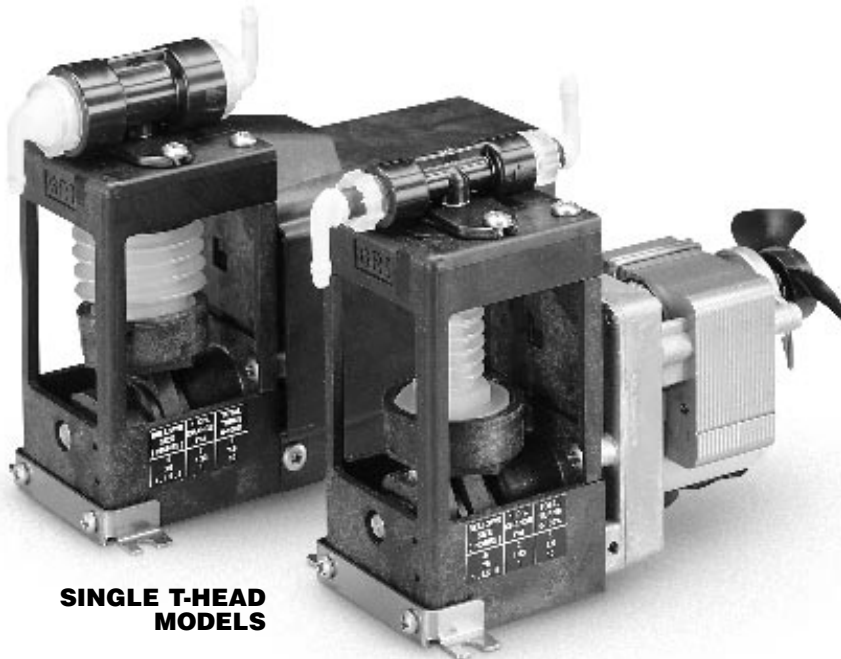

**SINGLE T-HEAD
MODELS**



**TANDEM
MODEL**

**SINGLE
MODEL**

Features:

- Average repeatability from stroke-to-stroke, $\pm 0.75\%$
- Dry run capability
- Self-priming
- No dynamic seals
- Superior corrosion resistance
- Economical
- Simple flow adjustment

Pump Specifications:

Average Repeatability —	From stroke-to-stroke $\pm 0.75\%$
Flow Rates —	To 270 ml/min
Fluid Temperatures —	To 140°F (60°C)
Discharge Pressure —	To 6 psi

Motors:

The standard motor available for the Mini Bellows Pump is an AC voltage synchronous motor. Motors are UL listed and continuous duty rated and are available in 115V, 50/60 Hz or 230V, 50/60 Hz.

MINI BELLOWS PUMPS - TYPICAL DIMENSIONS

Single Model

Weight of single mini bellows pump: 0.67 lb.

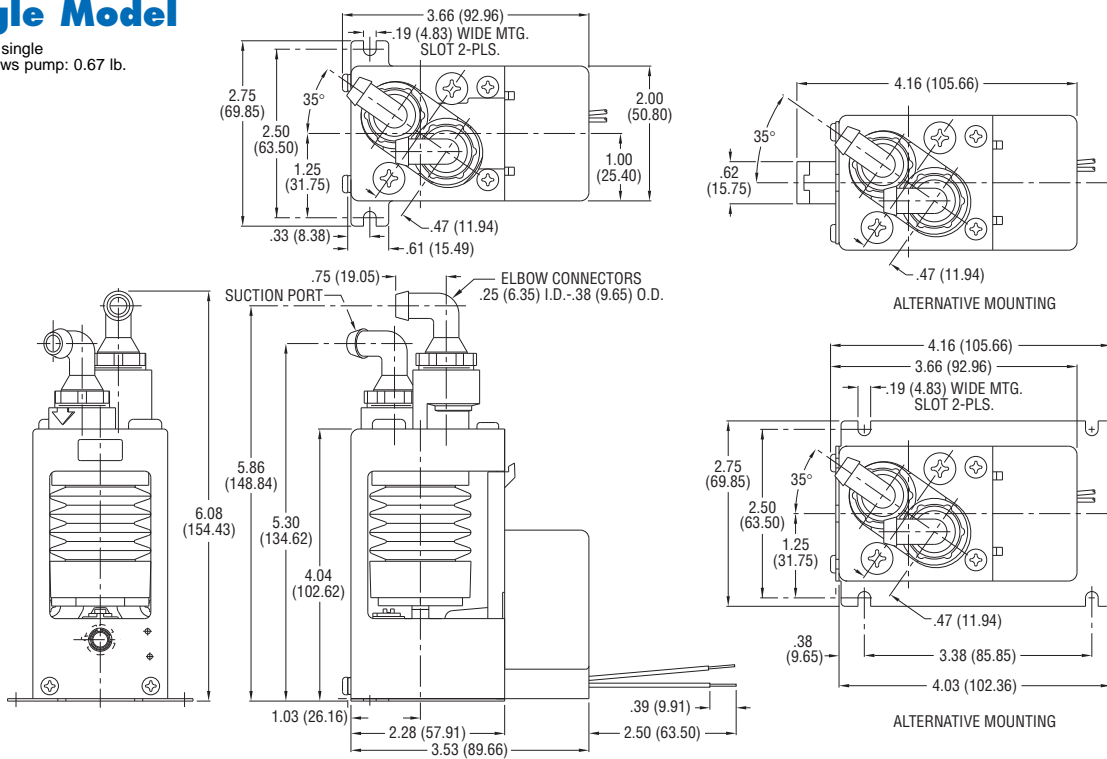

2-Tandem Model

Weight of 2-tandem mini bellows pump: 1.0 lb.

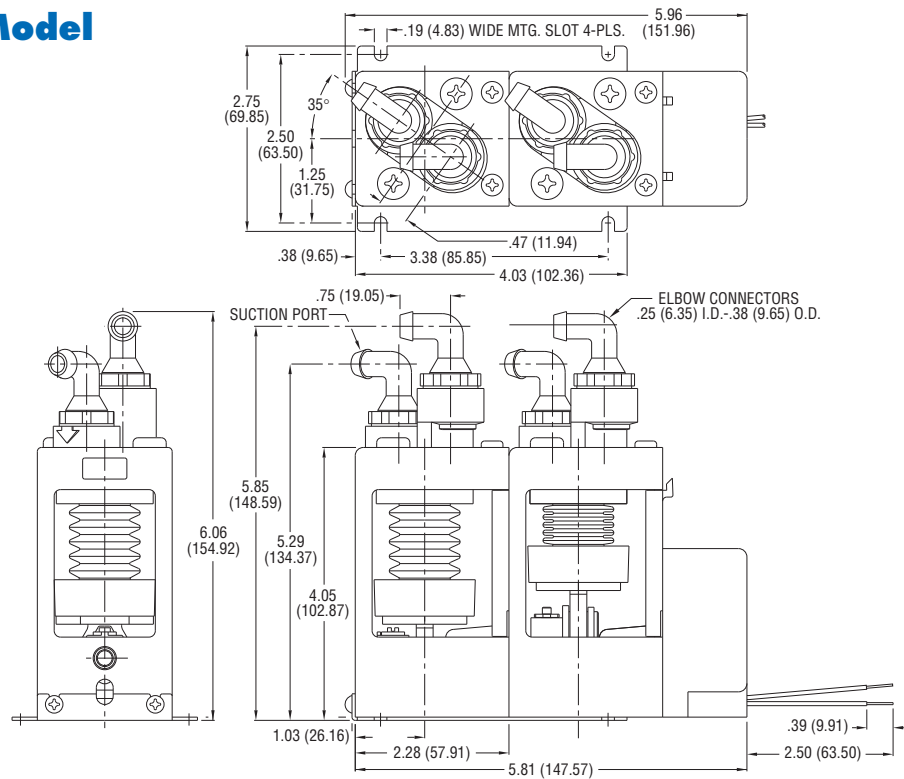

Dimensions in Inches
(Dimensions in Millimeters)

MINI BELLOWS PUMPS - TYPICAL DIMENSIONS

Single T-Head Model

Weight of single mini bellows pump: 0.67 lb.

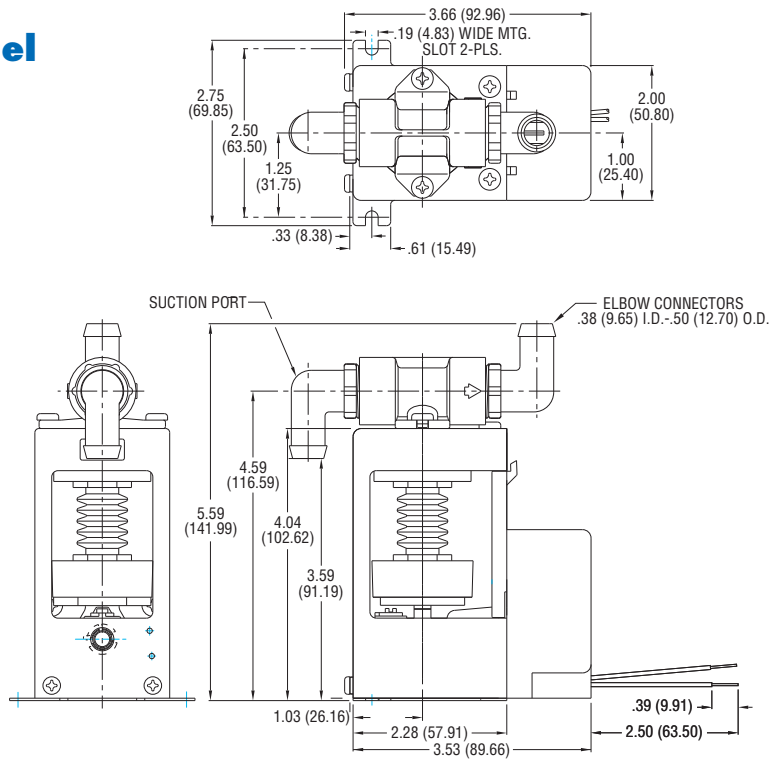

2-Tandem T-Head Model

Weight of 2-tandem mini bellows pump: 1.0 lb.

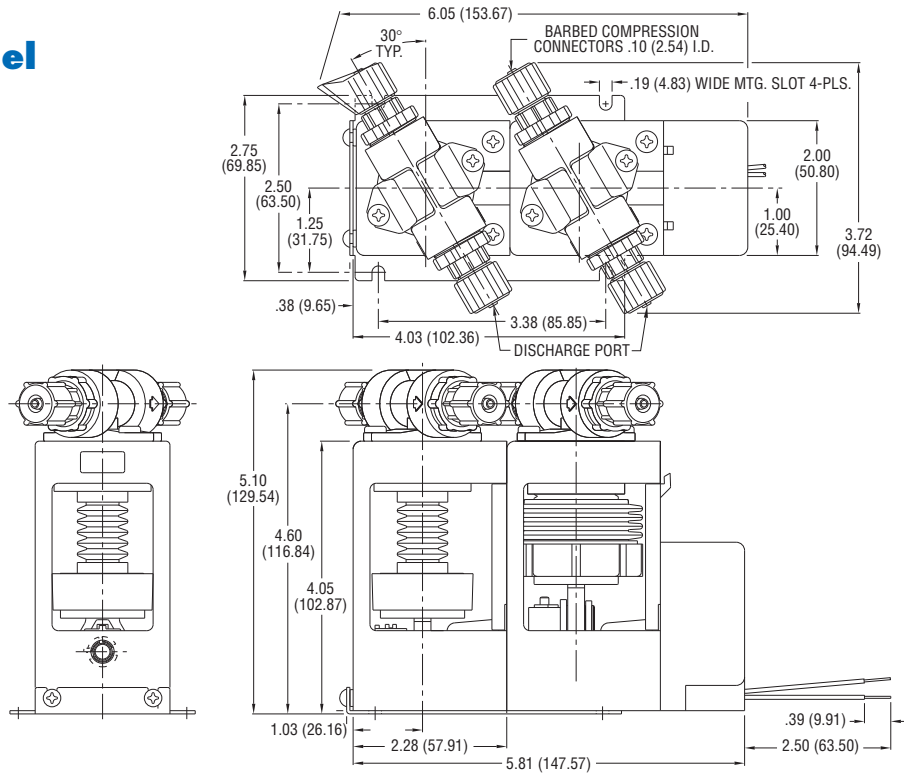

Dimensions in Inches
(Dimensions in Millimeters)

