

Centrifugal *Pumps*

Centrifugal pumps are designed to transfer both corrosive and non-corrosive fluids at maximum hydraulic efficiencies. Centrifugal pumps are not self-priming and must be used in applications where flooded suction exists. These pumps can not be run dry.

Typical applications include commercial and residential heating and cooling systems, commercial coffee urns, ice makers, dish and glassware washers, laundry appliances, plating systems, agricultural sprayers and industrial floor scrubbers.

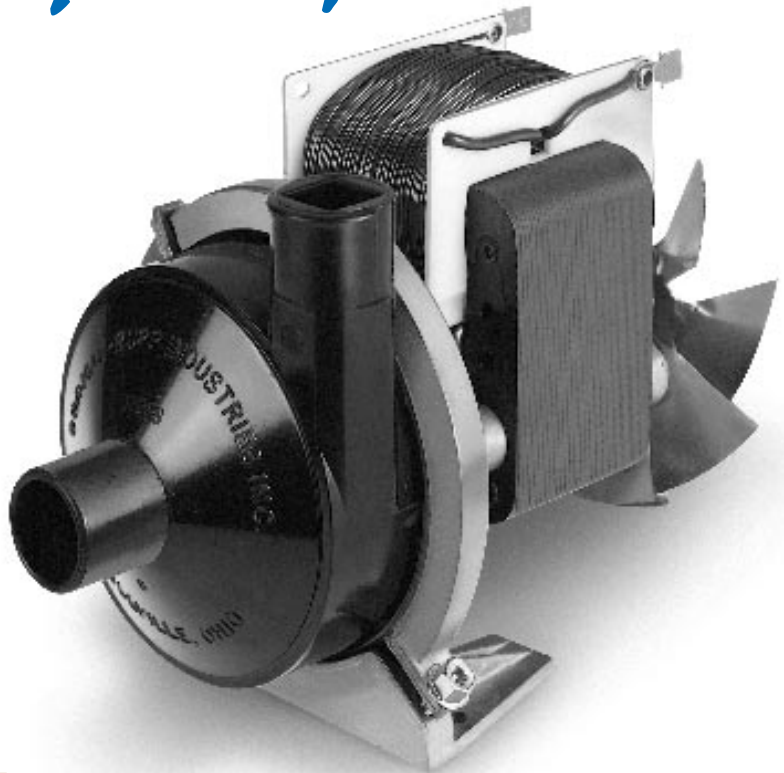

Features:

- Hydraulically efficient
- Corrosion resistant

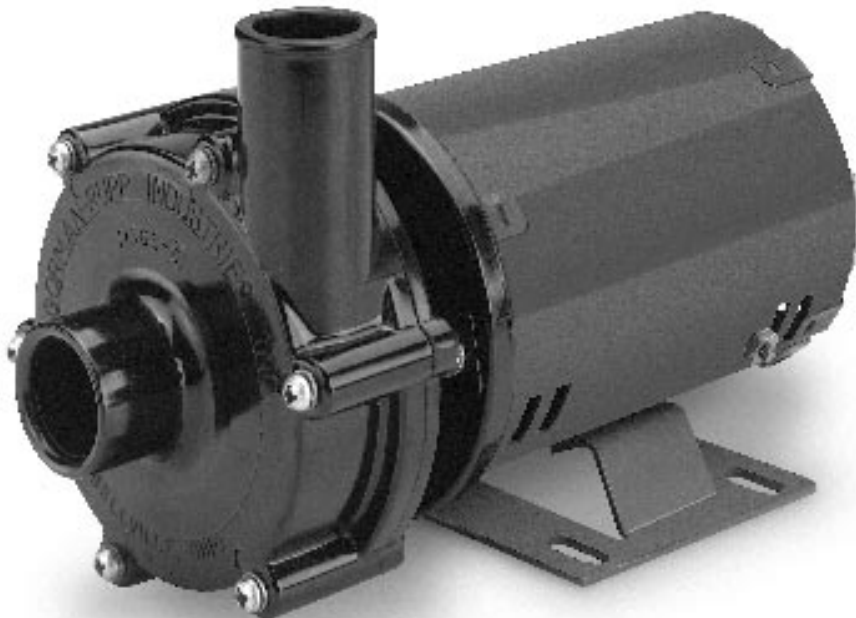

Centrifugal Pump Specifications:

Flow Rates — Range to 60 gpm; discharge heads to 85 feet

Fluid Temperature — To allow for optimum life, pumps with lip seals are limited to 180°F (82°C) and pumps with mechanical seals permit operation to 220°F (104°C)

All motors are rated for continuous duty, thermally protected and UL listed.

Do not run pumps dry.

Materials in Contact with Solution:

See individual pump series.

Selection Procedure:

Determine the flow and discharge head requirements for your system. The performance curves on this page provide the flow rates for each centrifugal pump series and should be used as a guide to locate the series where additional details can be obtained.

Select the model that most closely meets your requirements. The performance curve characteristics of a pump model may not meet the exact requirements of your application. It may be necessary to throttle the discharge of a pump with more flow or head capacity to fine tune the performance.

Ensure chemical compatibility of the model chosen by referring to the Chemical Resistance Section and checking all materials in contact with solution.

PERFORMANCE CURVES	
Series	Curve
5600	A
200	B
100	C
2800	D
149	E
120	F
800	G
3900	H
Hi-Speed	I
2700	J

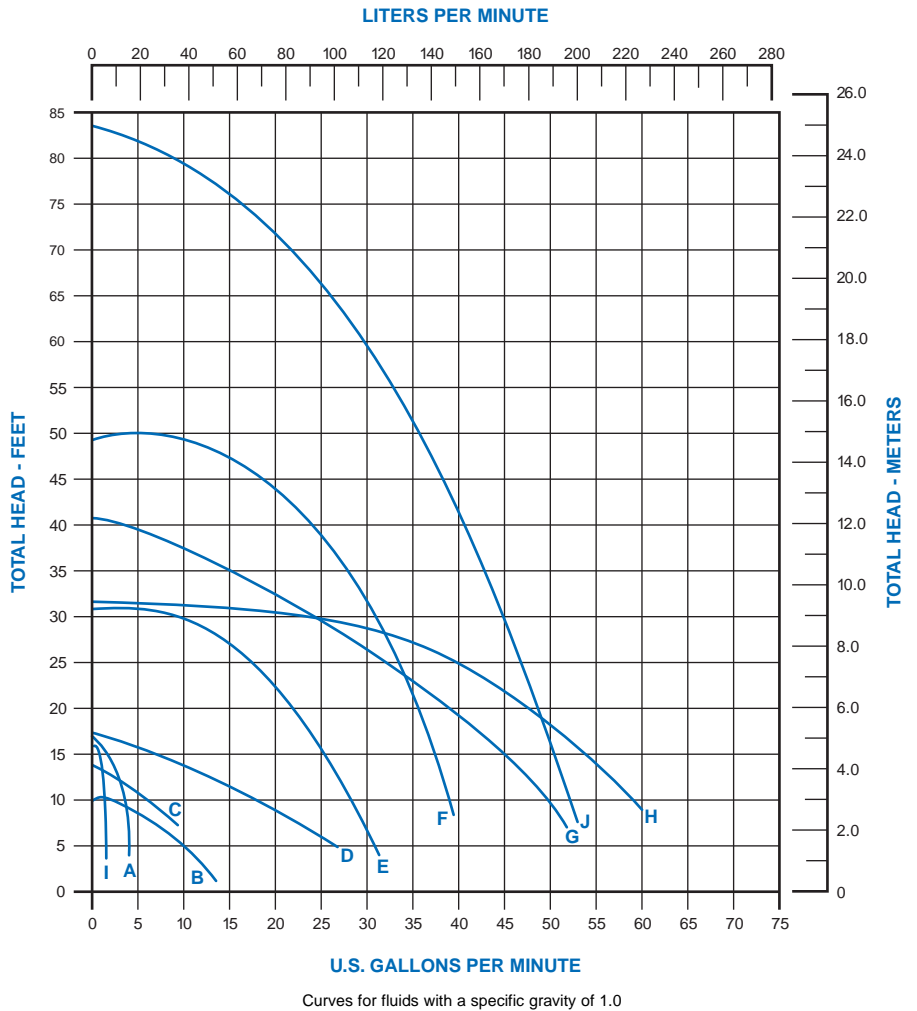
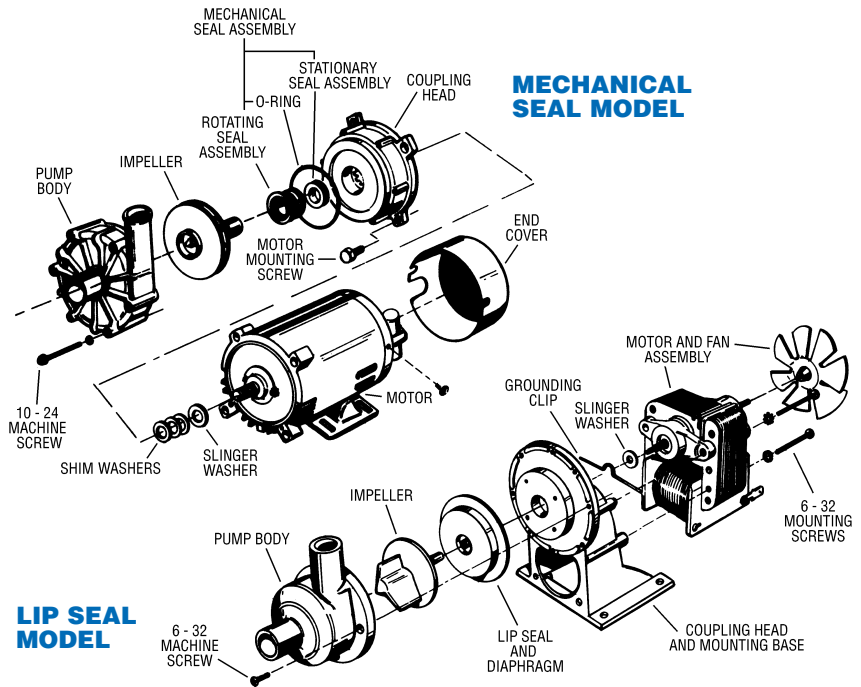

The above performance curves are designed to serve as a reference guide for locating a pump with the approximate performance range to meet your application (please consult the factory with exact application specifications). Each individual pump series is identified in the chart for each corresponding curve.