



Piston Diaphragm Pumps

Product Overview

Piston diaphragm pumps are positive displacement pumps designed to economically transfer small volumes of fluid at low discharge pressures. The lightweight, compact pumps are self-priming, corrosion resistant and can handle viscous fluids. These features make the pumps ideal for high volume copy machines, scientific and laboratory instruments and other chemical dispensing applications.

Operation:

Standard models are constructed with 12 or 24 volt DC solenoids. A switch is required to supply pulsed voltage to the pump. The energized solenoid pulls the piston and diaphragm up, drawing fluid into the pump. A spring forces the piston back to its original position when the solenoid is de-energized, forcing fluid out of the pump, and the cycle is repeated. Valves are utilized to prevent back-flow into the pump and to maintain prime.

Specifications:

Flow Rate: Range to 250 microliters per stroke

Max Discharge Pressure: Range to 2.6 psi (6')

Self-Priming: To 3 feet

Max Fluid Viscosity: To 300 centistokes

Max Fluid Temperature: To 200°F (93°C)

Typical Duty Cycle: 1 cycle/second (1/2 sec. on - 1/2 sec. off). Higher frequency operation achievable with external driver.

Metering Accuracy: ±2% stroke-to-stroke (for a stationary setup)

I.D. Tubing Size: 3/16"

Approximate Weight: .265 lb.

Note: Positive suction head above 6" requires tight valves; consult factory for availability.

Features:

- Economical
- Self-priming
- No dynamic seals
- No backflow
- Continuous duty rated
- Corrosion resistant
- Dry run capability

OEM Options:

To meet OEM specifications, the following features can be added:

- Fixed flow up to 500 microliters per stroke for low heads
- Fixed flow can be down to 100 microliters per stroke
- Field adjustability with screw and locking nut
- Alternate materials of construction
- Stepper linear actuator can replace solenoid
- Various solenoid voltages
- Better repeatability

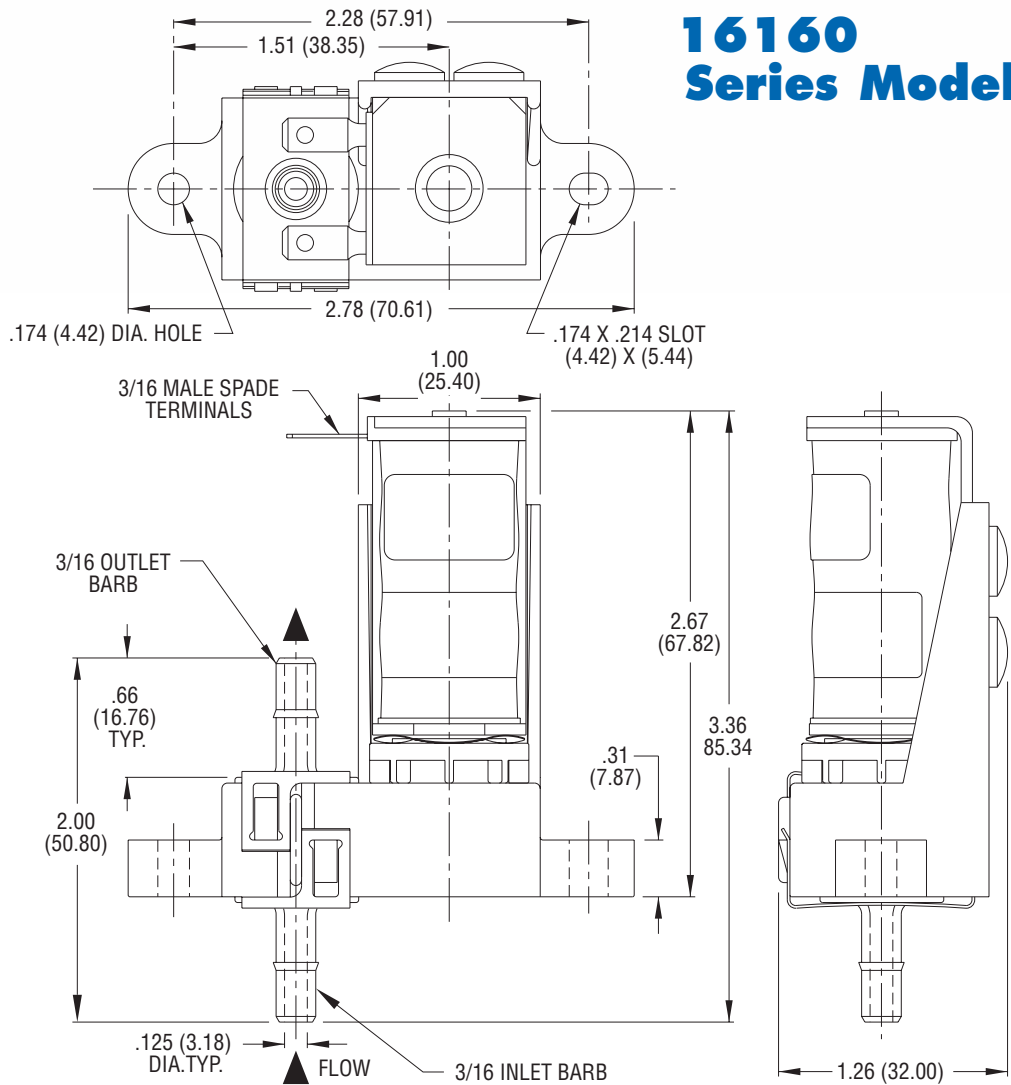

Dimensions in Inches (Dimensions in Millimeters)

[Contact Us](#)

[Online Inquiry](#)

The Pump People



180 Hines Ave. • Bellville, OH 44813 • PH: 419-886-3001 • FAX: 419-886-2338 • GRIsales@GRIpumps.com • www.GRIpumps.com