



DIVISION OF THE GORMAN-RUPP COMPANY
 Phone (419) 886-3001 • FAX (419) 886-2338
 grisales@gripumps.com • www.gripumps.com

SERVICE DATA SHEET

MINI BELLOWS METERING PUMP

DESCRIPTION

The bellows pump size is the actual outside diameter of the bellows. The pump operates on an adjustable stroke, positive displacement principle. Output is adjusted by changing the stroke. The pump is driven by a thermally protected gearmotor which is attached to an adjustable eccentric hub. The bellows, pump body, tubing connectors and valve seats are made of polypropylene (PPR).

Exposure of the motor to extremely dusty or corrosive environment may reduce life.

PRIMING

The pump is self-priming under most conditions: however, the priming ability lessens with greater suction lift, higher discharge head, or with reduced stroke. For dry start up on pumps with anti-siphon spring adjusted at low stroke, pump may not prime. Remove anti-siphon spring, prime pump and replace spring.

After the pump has been primed and is full of liquid, subsequent repriming ability will be improved.

FLOW ADJUSTMENT

Flow rate is modified with the adjustment screw on the crank assembly. Rotate adjusting screw clockwise to increase flow and counter-clockwise to decrease flow. Do not turn or loosen lock nut on adjusting screw.

Do not reduce output flow by restricting suction or discharge as this will cause excessive pressure within the pump.

PRESSURE

The bellows pump has the ability to discharge into a pressurized system; however, if system or discharge pressure exceeds maximum psi rating of bellows, it may cause damage to the bellows or gearbox.

All mini bellows pumps have a maximum rating of 5 psi.

NOTE: Pumps are designed for use with liquid up to 120°F (49°C) at catalog rated pressure. Reduce the maximum psi rating by 50% for temperatures over 120°F. Not applicable in liquids over 140°F.

VISCOSITY

The pump has been designed to handle a wide range of liquid viscosities. It should be noted, however, that when pumping thicker liquids it may be necessary to increase the size of connectors and tubing to relieve the pressure buildup within the pump assembly. It is good practice when pumping the heavier liquids to keep the liquid velocity (pump speed) as low as possible.

When pumping heavy suspensions which may tend to settle out, extremely corrosive solutions or any liquid which may tend to become more viscous with time, flush pump after use to increase pump life.

CHEMICAL SERVICE

The bellows pump will handle many different kinds of liquids. For specific chemical service, refer to our Full Line Catalog, Form No. 10001.

TEMPERATURE

Pumps are designed to operate in 140°F (60°C) ambient temperature. For higher ambient temperature operations, consult the factory.

TROUBLESHOOTING GUIDE

The troubleshooting guide is a suggestion or aid in helping solve problems that might arise.

NOTE: Never work on pump without making certain power is off.

PUMP LEAKS

1. Bellows loose – Turn adjusting screw to full stroke, then rotate crank assembly to maximum bellows compression. Tighten plastic nut on crank assembly to 14 in.-lbs. maximum. **CAUTION:** Overtightening will distort bellows and cause leaks.
2. Connectors loose – Tighten to 5-1/2 to 6-1/2 in.-lbs. torque (finger tight).
3. O-ring defective or missing – See illustration.

MOTOR WILL NOT RUN

1. Cord, plug or switch defective.
2. Wires pulled loose.
3. Motor overtemperature thermostat open, motor overheating or poor ventilation.

UNIT WILL NOT PRIME

1. Pump leaks on suction side (see "Pump Leaks" section).
2. Bellows ruptured.
3. O-ring defective or missing – See illustration.
4. Valves inverted or reversed.
5. Pump air-locked – Temporarily bleed off discharge pressure.
6. Stroke too short – Adjust screw to increase stroke.
7. Viscosity too high.
8. Anti-siphon spring with pump adjusted at low stroke.

ERRATIC OR LOW FLOW

1. Valves dirty – Dirt or foreign material in valves.
2. Crank set screw broken.
3. Valves not seating.
4. Connectors loose.

UNIT WILL NOT PUMP

1. Bellows ruptured.
2. Crank broken.
3. Crank set screw broken.
4. Valves dirty – Dirt or foreign material in valves.
5. Valves may have deteriorated.

WARRANTY

Gorman-Rupp Industries warrants to Buyer that products sold by it will upon shipment conform to the description on the face hereof and any written specifications expressly approved by Seller and be free from defects in title, material and workmanship. NO OTHER WARRANTY, WHETHER EXPRESS OR IMPLIED, INCLUDING ANY WARRANTY OF MERCHANTABILITY OR FITNESS FOR A PARTICULAR PURPOSE, SHALL EXIST IN CONNECTION WITH ANY PRODUCTS SOLD BY SELLER, AND ALL SUCH WARRANTIES ARE HEREBY EXPRESSLY EXCLUDED.

WARNING

DANGER:

Improper application, installation, adjusting, or servicing can result in serious injury or death. Always disconnect power source before working on these products.

Caution:

Products with electric motors must be properly grounded and may start automatically at any time. For product information, consult Gorman-Rupp Industries, Bellville, Ohio 44813, Phone (419) 886-3001.

EXPLODED VIEW – MINI BELLOWS METERING PUMP

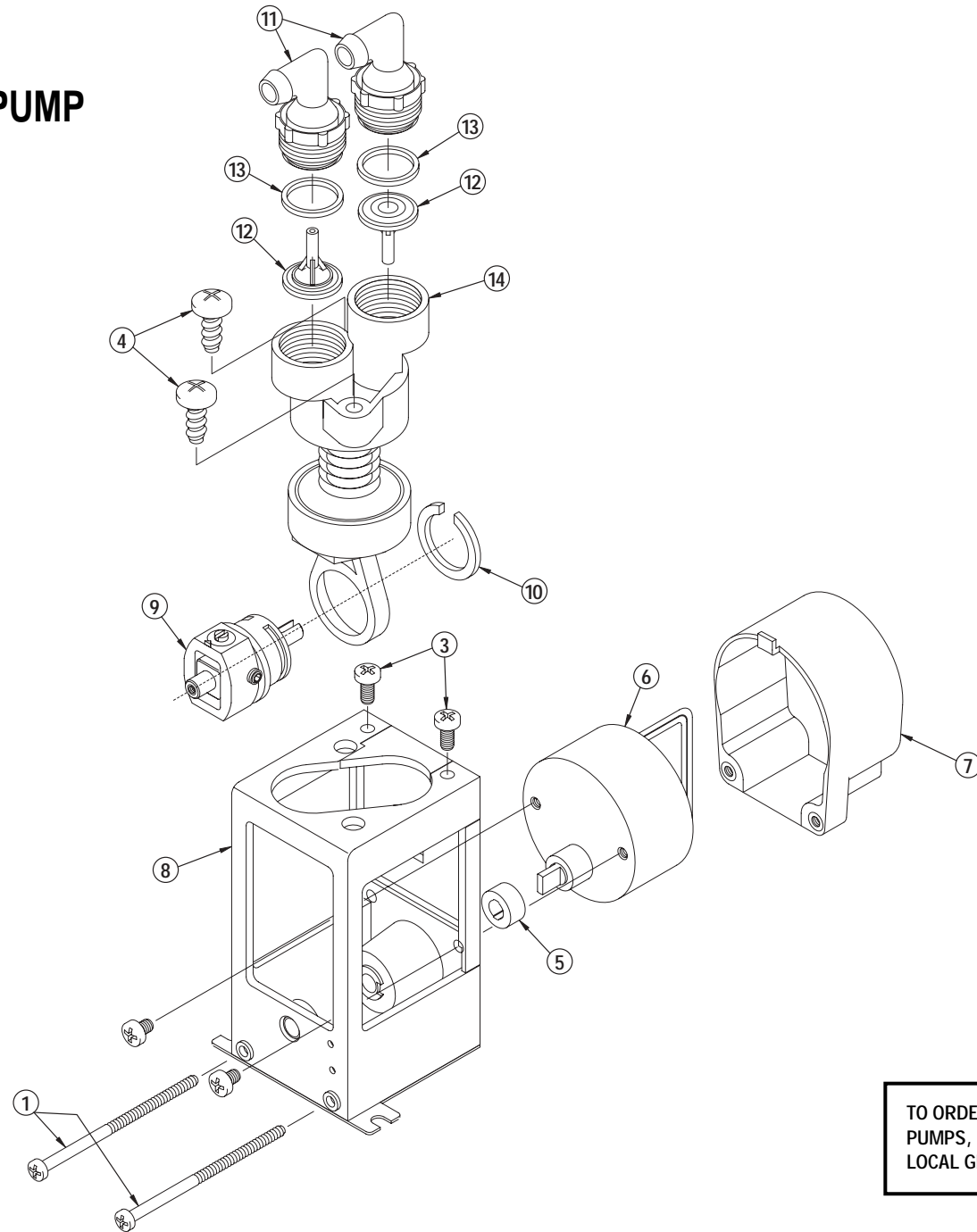

TO ORDER REPLACEMENT
PUMPS, OR KITS, CALL YOUR
LOCAL GRI DISTRIBUTOR.

PARTS LIST

ITEM	REQ.	DESCRIPTION	ORDERING INFORMATION
1	2	6-20 Thread Cutting Screws	See note below
2	2	8-32 x 5/16" Motor Mtg. Screws	See note below
3	2	8-18 x 1/2" Screws	See note below
4	2	1/4-14 x 5/8" Screws	See note below
5	1	Coupler	See note below
6	1	Motor	See note below
7	1	Motor Cover w/Vents	See note below
8	1	Mounting Bracket & Motor Mtg. Plate	See note below
9	1	Crank Assembly	Included in Crank Assembly Replacement Kit - See Chart
10	1	Snap Ring	Included in Crank Assembly Replacement Kit - See Chart
11	2	Connectors & Connector Nuts	Included in Tubing Connector Kit - See Chart on Back Page
12	2	Valve Assemblies	Included in Poppet or Duckbill Valve Kit - See Chart
13	2	O-Rings	Included in Bellows Module Kit - See Chart
14	1	3/4" Mini Bellows Module	Included in Bellows Module kit - See Chart

NOTE: Parts not available unless stocked by GRI Distributor or purchased in OEM quantities.

DUCKBILL VALVES AND O-RINGS

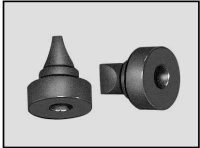

1/2" Bellows Kit



3/4", 1", 1-1/2" and 2" Bellows Kit (Valve extension required only on suction port.)

BELLOWS MODULE REPLACEMENT KITS

MATERIALS	BELLOWS SIZE				
	1/2"	3/4"	1"	1-1/2"	2"
EPT/EPDM	02501-315	02501-356	02501-357	02501-358	02501-359
Hypalon®	02501-313	02501-372	02501-373	02501-374	02501-375
Viton®/Fluoroelastomer	02501-314	02501-376	02501-377	02501-378	02501-379

CRANK ASSEMBLY REPLACEMENT KITS

BELLOWS SIZE	CHART LOCATION	KIT NUMBER
1/2"	1, 3	02501-345
3/4"	1, 3	02501-346
1", 1-1/2" & 2"	1, 3	02501-344
1/2"	2	02501-348
3/4"	2	02501-349
1", 1-1/2" & 2"	2	02501-347

MOTOR	1
--------------	----------

MOTOR	2	3
--------------	----------	----------

POPPET VALVE KITS

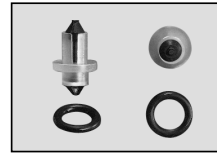

1/2" Poppet Valve Kit

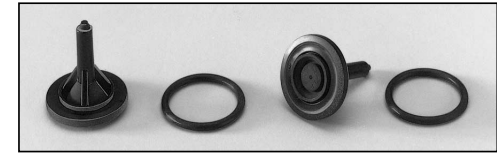

3/4", 1", 1-1/2" & 2" Poppet Valve Kit

MATERIALS	BELLOWS SIZE			
	3/4"	1"	1-1/2"	2"
Butyl	02500-327 (X-031)	02500-327 (X-031)	02500-327 (X-031)	-
EPT/EPDM	02500-322 (X-032)	02500-322 (X-032)	02500-322 (X-032)	02500-322 (X-152)
Hydrin	02501-528 (X-033)	02501-528 (X-033)	02501-528 (X-033)	02501-528 (X-153)
Kel-F®	02500-355 (X-034)	02500-355 (X-034)	02500-355 (X-034)	02500-355 (X-154)
Hypalon®	02500-325 (X-035)	02500-325 (X-035)	02500-325 (X-035)	02500-325 (X-155)
Viton®/Fluoroelastomer	02500-319 (X-036)	02500-319 (X-036)	02500-319 (X-036)	02500-319 (X-156)
Silicone	02500-324 (X-038)	02500-324 (X-038)	02500-324 (X-038)	02500-324 (X-158)
Nitrile	02500-320 (X-039)	02500-320 (X-039)	02500-320 (X-039)	02500-320 (X-159)

MATERIALS	BELLOWS SIZE			
	3/4"	1"	1-1/2"	2"
Butyl	02500-604 (X-111)	02500-604 (X-111)	02500-604 (X-111)	-
EPT/EPDM	02500-605 (X-112)	02500-605 (X-112)	02500-605 (X-112)	02500-605 (X-142)
Hydrin	02500-606 (X-113)	02500-606 (X-113)	02500-606 (X-113)	-
Kel-F®	02500-607 (X-114)	02500-607 (X-114)	02500-607 (X-114)	-
Hypalon®	02500-608 (X-115)	02500-608 (X-115)	02500-608 (X-115)	02500-608 (X-145)
Viton®/Fluoroelastomer	02500-609 (X-116)	02500-609 (X-116)	02500-609 (X-116)	02500-609 (X-116)
Silicone	02500-610 (X-118)	02500-610 (X-118)	02500-610 (X-118)	-
Nitrile	02500-611 (X-119)	02500-611 (X-119)	02500-611 (X-119)	-

NOTE: "X" codes are used for identification purposes only, to show elastomer in pump. Use "X" codes on pump label as a guide. Use 8-digit kit number beside corresponding "X" code when ordering replacement valve kit.

Example: If X-111 is on pump label, order kit number 02500-604.

TUBING CONNECTORS (2 PER KIT) – POLYPROPYLENE

T-CODE	T-CODES			
	FOR ELASTOMERIC TUBING SIZE	CONNECTOR TYPE	BELLEWS MODULE SIZE	KIT PART NUMBER
T-001	1/8" ID x 1/4" OD	Barbed Compression	1/2"	02500-312
T-002	1/4" ID x 3/8" OD	Barbed Compression	1/2"	02500-635
T-003	3/8" ID	Barbed	3/4", 1", 1-1/2" & 2"	02500-352
T-004	1/2" ID	Barbed	3/4", 1", 1-1/2" & 2"	02500-353
T-005	1/8" pipe thread	Female NPT	3/4", 1", 1-1/2" & 2"	02500-258
T-006**	1/8" ID x 1/4" OD	Barbed Compression	3/4", 1", 1-1/2" & 2"	02500-259
T-007**	1/4" ID X 3/8" OD	Barbed Compression	3/4", 1", 1-1/2" & 2"	02500-260
T-008	3/8" ID	Elbow Swivel, Barbed	3/4", 1", 1-1/2" & 2"	02500-261
T-009	1/2" ID	Elbow Swivel, Barbed	3/4", 1", 1-1/2" & 2"	02500-354
T-011	1/4" ID	Elbow Swivel, Barbed	3/4", 1", 1-1/2" & 2"	02501-337
T-012*	4mm (5/32") ID	Elbow Swivel, Barbed	3/4", 1", 1-1/2" & 2"	02501-246
T-013*	4mm (5/32") ID	Elbow Swivel, Barbed	1/2" & 3/4"	02501-541
T-014	1/4" ID	Barbed	3/4", 1", 1-1/2" & 2"	02501-673

NOTE: "T" codes are used for identification purposes only, to show tubing connectors used in pump. Use "T" code on label as a guide. Use 8-digit kit number beside corresponding "T" code when ordering replacement tubing connector kit.

Example: If T-008 is on pump label, order kit number 02500-261. Kit includes (2) Connectors and (2) Connector Nuts.

For flows of 1800 ml/min and above, 1/2" ID tubing connectors recommended.

*Use of 4mm connector is limited by flow rate; please contact factory with specifications.

**Cost added for connector

TUBING CONNECTORS



Registered Trademark Names

VITON®/FLUOROELASTOMER..... DuPont Dow Elastomers
 HYPALON®..... DuPont Dow Elastomers
 KEL-F® 3M



DIVISION OF THE GORMAN-RUPP COMPANY
 Phone (419) 886-3001 • FAX (419) 886-2338
 grisales@gripumps.com • www.gripumps.com