

# 800 Series



## Pump Specifications:

**Flow Rates** — Range to 50 gpm; maximum head 38 feet (abrasive handling capabilities)

**Motors** — 115V, 50/60 Hz; 230V, 50/60 Hz  
 1/3 hp, open, drip-proof, capacitor start, thermally protected

**Fluid Temperature** — To 220°F (104°C)

## Materials in Contact with Solution:

**Body** — Nitrile  
**Impeller** — Nitrile  
**Seal** — Carbon and Carbon faces with Nitrile elastomers

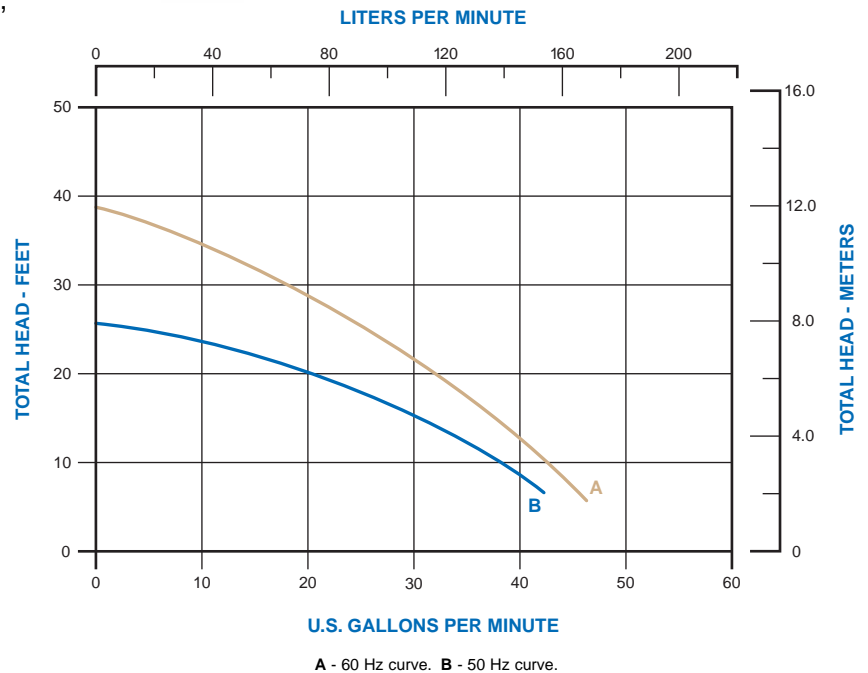

MODEL SPECIFICATIONS										
Model Number	Series	Seal	Volts	Hz	Amps	Motor Type	Shell	Typical Curve		Approx. Wt.
								50 Hz	60 Hz	
08107-002	800	Mech	115/230	60	5.2/2.6	Cap. Start	Open D.P.	B	A	15.1 lbs.
			115/230	50	6.9/2.6					

## CENTRIFUGAL PUMPS - TYPICAL DIMENSIONS

### 800 Series Model

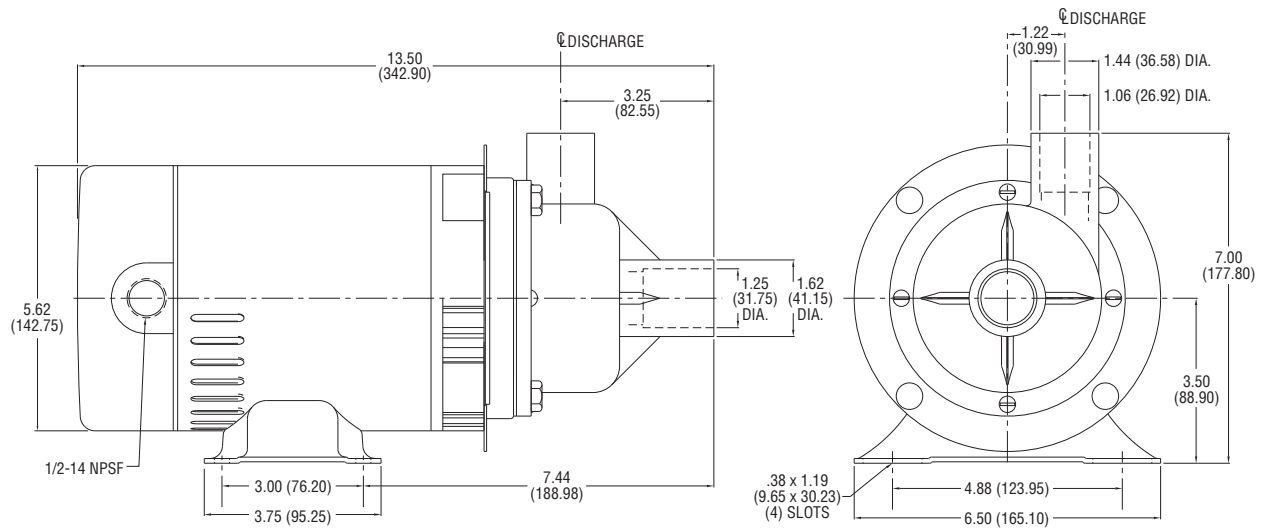

Dimensions in Inches  
(Dimensions in Millimeters)

## OEM Options

- Body** — Buna N
- Impeller** — Buna N
- Seal** — Carbon vs.  
316 Stainless Steel  
with Buna N, Nitrile  
and 302 Stainless  
Steel components