

**INSTRUCTION MANUAL**

IM236



# Sump Pumps

**INSTALLATION, OPERATION AND MAINTENANCE INSTRUCTIONS**

 **GOULDS**  
WATER TECHNOLOGY  
a **xylem** brand

**TO AVOID SERIOUS OR FATAL PERSONAL INJURY OR MAJOR PROPERTY DAMAGE, READ AND FOLLOW ALL SAFETY INSTRUCTIONS IN MANUAL AND ON PUMP.**



This is a **SAFETY ALERT SYMBOL**. When you see this symbol on the pump or in the manual, look for one of the following signal words and be alert to the potential for personal injury or property damage.



Warns of hazards that **WILL** cause serious personal injury, death or major property damage.



Warns of hazards that **CAN** cause serious personal injury, death or major property damage.



Warns of hazards that **CAN** cause personal injury or property damage.

**NOTICE:** Indicates special instructions which are very important and must be followed.

**THIS MANUAL MUST BE KEPT WITH THE PUMP.**

**MAINTAIN ALL SAFETY LABELS.**

## IMPORTANT PRE-INSTALLATION INFORMATION



**!** All electrical work must be performed by a qualified technician. Always follow the local applicable electrical code.

**!** The pump must be connected to a dedicated electrical circuit protected by a properly sized circuit breaker or fuses. Install a disconnect where required by code. Code questions should be directed to your electrical inspector. **See Chart 1 for specific information.**

**!** Disconnect electrical power before installing or servicing the pump. The motor's automatic thermal overload protection may allow an overheated pump to restart unexpectedly.

**!** Pump is not designed for use in swimming pools, open bodies of water, hazardous liquids, or where flammable gases exist.

**!** Pumps and floats equipped with a 3-prong grounded plug must be connected to a 3-wire receptacle. Do not attach to extensions or connectors without a 3-prong grounded plug. **NOTE:** Removing the plug from the power cord is not allowable per NEC code. Removing the plug will void the agency listing.

**!** **CAUTION** This pump has been evaluated for use with water only.

**!** **WARNING** Risk of electric shock – this pump is supplied with a grounding conductor and grounding-type attachment plug. To reduce the risk of electric shock, be certain that it is connected only to a properly grounded, grounding-type receptacle.

## 1. GENERAL INFORMATION

- 1.1. Sump pumps are designed to operate intermittently and usually seasonally. It is recommended that you test the pump before your rainy season begins to insure that the pump and switch are operating properly.
- 1.2. We suggest installing a high water alarm system and a battery back-up pump system for finished basements or areas where flooding will cause property damage. A back-up generator is another option you can discuss with your pump installer. Most power outages occur during rain storms, just when you need your sump pump the most! Pump manufacturer's warranties cover only the pump. Labor and incidental damage such as flooding is not covered.

## 2. PRE-INSTALLATION CHECKS

- 2.1. Open all cartons and inspect for shipping damage. Report any damage to your supplier immediately.
- 2.2. Verify that all equipment is the correct voltage. Warranty does not cover damage caused by connecting pumps and controls to incorrect voltage.
- 2.3. Is your basin sized correctly and the proper type for the location?

*Diameter* - It must be wide enough to allow the pump and switch to physically fit and provide room for the switch to operate freely. The vertical switch models typically require less diameter than the wide-angle float models. See "*min. basin diameter*" in Chart 1.



*Depth* - It must be deeper than the minimum depth at which the switch turns the pump On. As an example, if the pump turns on at 15" you want to use a basin deeper than 15". See "*On level*" in Chart 1.



*Style* - There are several sump basin styles available. The location of the sump determines if you require a cover and what type you require. It is important to keep debris from entering the sump and clogging the pump. An open sump in a traffic area such as a basement is dangerous. If children or pets will be playing

in the area a bolt-on or child-proof cover is recommended.

## 3. PIPING

- 3.1. Discharge pipe should be the same size as the pump discharge to insure optimum performance. Using undersized pipe may dramatically reduce the flow and therefore waste energy. Your pump supplier can suggest the correct pipe for your installation.
- 3.2. Install a threaded pipe adapter, matched to the pipe type you are using, into the threaded pump discharge. One end will have a male thread and the other end will have a barbed connector, compression fitting or solvent weld connector. Use Teflon<sup>®</sup> tape on all threaded joints. If using solvent welded pipe and fittings it is best to dry fit them first and after verifying the fit, solvent weld. A union installed just above the sump or basin cover will facilitate future maintenance and replacement. See *Chart 1 for discharge sizes*.
- 3.3. Install a line check valve within 2 feet of the pump. Install per valve manufacturer's instructions.

**IMPORTANT** - Drill a 1/8" (3.2mm) relief hole in the discharge line approximately 2" (51 mm) above the pump discharge connection but below the check valve and within the sump. This "relief" hole allows trapped air to escape from the pump and prevents air-locking the pump. Failure to drill this hole is a major cause of sump pumps failing to pump after long periods of inactivity such as seasonal use. Model ST is self-venting - no hole is required.

## 4. INSTALLATION IN SUMP

- 4.1. The pump can be placed directly on the bottom of a poly or fiberglass sump basin or a concrete sump bottom. If the bottom is packed gravel the stones must be larger than 1/2" (13mm) in diameter and the pump should be placed on bricks for support.
- 4.2. After connecting the discharge pipe to the pump it can be lowered into the sump (basin). Always lower the pump by the handle and the pipe, never by the power cord. Place the pump against the basin wall so the switch is to the center. See "*Installation Data*".

- 4.3. Check to insure all piping connections are tight. The pipes should be supported by fastening to floor joists or wall. This will prevent the pump from moving in the sump. If it moves the switch could get stuck and either keep the pump running or not let it turn on.
- 4.4. The power to the outlet should be Off at this point. The dedicated outlet should supply power only to the pump.
- 4.5. Our sump pumps have either a single power cord for pumps with built-in switches or two power cords for pumps with piggyback switches:  
*Built-In/Single Cord* - plug the single power cord into a dedicated power outlet.  
*Piggyback/Two Power Cords* - insert the piggyback switch male plug into a dedicated power outlet. You then plug the standard male pump plug into the back, female side, of the piggyback switch plug.
- 4.6. Fasten the power cords to the discharge pipes using tie wraps or electrical tape. Coil and store any excess power cord outside the sump.

## 5. OPERATION

- 5.1. Turn the power On at the breaker panel and/or the disconnect switch.
- 5.2. Fill the basin with water and observe where the pump turns On and Off. It should go On well before the water overflows the top of the sump. The pump should go Off before the water goes below the pump suction. The On-Off cycle on models with wide-angle float switches is adjustable. Adjustment is made by changing the tether length between the switch body and the switch tether (pivot) point. The tether length cannot be less than 3" – 3.5". Tethers less than 3" may not allow the float to drop down enough to turn off. See "Installation Data".
- 5.3.  **WARNING** Install a cover on the sump basin if there is a danger of debris, children, or pets falling into the basin. See Basin "Style" in Section 2.3.

## 6. SEASONAL SERVICE / MAINTENANCE

- 6.1. If your sump pump only operates seasonally and then sits idle for months it is recom-

mended that you test the pump before your rainy season begins. Fill the sump with water and check for debris and proper switch operation. Remove any debris which could clog the suction strainer or jam the switch. Insure that the switch operates freely and does not hit the sump wall or hang-up on piping or power cords.

## 7. OPTIONS

- 7.1. Your pump supplier has a full line of basins, covers, high water alarms, and battery back-up pump systems available to complete your system. We also sell simplex and duplex pump control panels. A duplex system is recommended when the inflow is constant and the pumps run almost continuously. The duplex system provides a back-up pump in the event the primary pump fails.

## 8. TROUBLE SHOOTING CHART

---

Extreme caution should be exercised when servicing electrical devices. Fatal injuries could result from electrical shock. Always disconnect the electrical power from the device being serviced unless it is necessary for the work being done.

### MOTOR NOT RUNNING

(See causes 1, 2, 3, 4, 6, 8)

### LITTLE OR NO LIQUID DELIVERED

(See causes 5, 6, 7, 8, 10)

### PUMP WILL NOT TURN OFF

(See causes 7, 8, 9, 10, 13)

### PUMP CYCLES CONSTANTLY

(See causes 9, 11, 12, 13)

### PROBABLE CAUSES:

1. Tripped thermal protector.
2. Open Circuit breaker of blown fuse.
3. Rotating parts binding.
4. Defective motor.
5. Air locked.
6. Low voltage.
7. System head too high.
8. Pump clogged.
9. Level control defective or switch not properly positioned.
10. Improper check valve direction.
11. Check valve leaking.
12. Incorrect size basin or wet-well.
13. Inflow excessive for size of pump.

**MODEL INFORMATION (CHART 1)**

Model No.	kW	Phase	Hertz	Volts	Nominal Current	Float Switch Style	Cord Length	Discharge Connection	Minimum Basin Diameter	Maximum Solids Size	Shipping Weight
STS21V	0.25	1	60	115	2.5 amps	Vertical	20'	1½"	12"	3/16"	9 lbs.
STS31V	0.33	1	60	115	4.5 amps	Vertical	20'	1½"	12"	3/16"	9 lbs.

**INSTALLATION DATA**

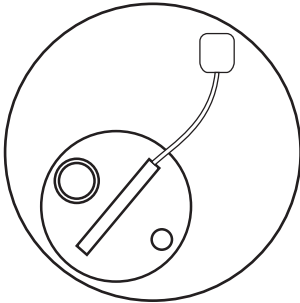

**Suggested Pump Positioning in Sump**  
*Figure 1*

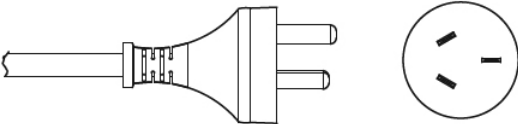

**Australian Plug**  
*Figure 2*

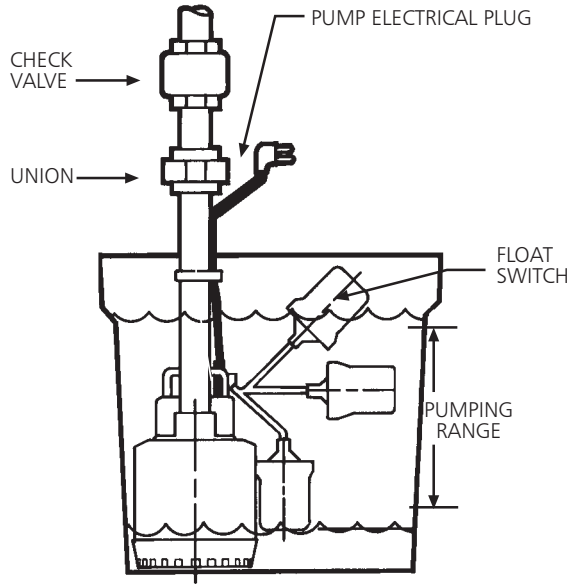

Typical Pump Installation in Sump

Figure 3

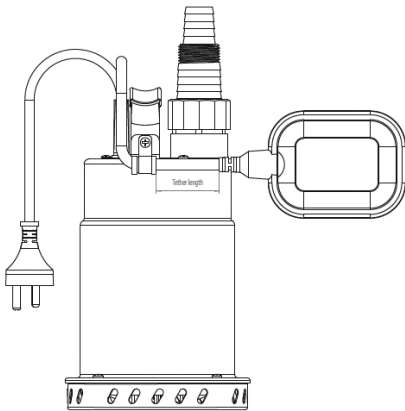

General Pump Configuration

Figure 4

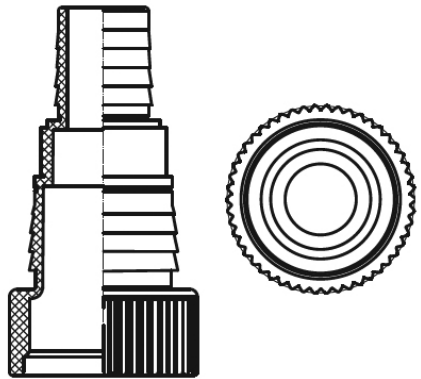

Hose Adapter

Figure 5



## GOULDS WATER TECHNOLOGY LIMITED WARRANTY

This warranty applies to all water system pumps and related accessories manufactured and/or supplied by Goulds Water Technology, provided the installation is in accordance with the Instruction Manual issued by the Manufacturer.

Any part or parts found to be defective within the warranty period shall be replaced at no charge to the buyer or any subsequent owner during the warranty period. The warranty period shall exist for a period of twelve (12) months from the date of installation or eighteen (18) months from the date of manufacture, whichever is shorter.

A consumer who believes that a warranty claim exists must contact the authorized Goulds Water Technology dealer from whom the equipment was originally purchased and furnish complete details regarding the claim for warranty.

### The warranty excludes:

- (a) Labor, transportation and related costs incurred by the consumer to make the alleged defective equipment available to the dealer for inspection.;
- (b) Re-installation costs of repaired equipment;
- (c) Reinstallation costs of replacement equipment;
- (d) Consequential damages of any kind; and,
- (e) Reimbursement for loss caused by interruption of service.

There are no warranties, expressed or implied, except such warranties as are definitely set forth herein. The Company shall not be liable for damage or wear to pump caused by abnormal conditions, failure to properly prime or to operate pump without flow or caused by corrosives, abrasives, or foreign objects. No obligations other than those herein set forth shall be binding upon the company.

### Australia

Xylem Water Systems Australia Pty. Ltd.  
Unit 3/1 Federation Way, Chifley Business Park  
Chifley Business Park  
Mentone, Victoria 3194, Australia  
Tel: +61.3.9551.7333 Fax: +61.3.9551.0321

### Korea

Xylem Water Solutions Korea Co., Ltd.  
4F, Dong-A Building , 789  
Yeoksam, Gangnam  
Seoul, 135-929, Korea  
Tel: +82.2.552.0553 Fax: +82.2.552.0557

### Singapore

Xylem Water Solutions Singapore Pte Ltd.  
1 Jalan Kilang Timor, #06-06  
Singapore 159303  
Tel: +65.6681.0166 Fax: +65.6681.0168

### Philippines

Xylem Water Systems International, Inc.  
12 Ring Road, LISP II  
Calamba Laguna 4027, Philippines  
Tel: +63.49.545.6810 Fax: +63.49.545.6817



### Xylem, Inc.

2881 East Bayard Street Ext., Suite A  
Seneca Falls, NY 13148  
Phone: (866) 325-4210  
Fax: (888) 322-5877

[www.xyleminc.com/brands/gouldswatertechnology](http://www.xyleminc.com/brands/gouldswatertechnology)

Goulds is a registered trademark of Goulds Pumps, Inc. and is used under license.  
Teflon is a registered trademark of Dupont.

© 2012 Xylem Inc. IM236 Revision Number 1 July 2012