



# Self-Priming Centrifugal Pumps with Explosion Proof Motors

- **Cast Iron Construction**
- **Viton® Seals with Carbon and Ni-resist Faces**
- **1-1/4", 1-1/2" & 2" NPT Port Sizes**
- **Self-priming to 20 Ft.**
- **Maximum Operating Pressure to 31 PSI**
- **Maximum Temperature 160° F**
- **Maximum Flow 128 GPM**
- **Maximum Head 72 Ft.**
- **Solids Handling up to 3/8" Diameter**
- **1/2 to 2 HP Single and Three (3) Phase 3450 RPM Motors**

This line of Gorman-Rupp explosion proof, self-priming centrifugal pumps is designed for use in hazardous environments and/or for handling flammable liquids. 1-1/4", 1-1/2" and 2" NPT port sizes available with single or 3-phase motors with horsepower from 1/2 to 2. All models are self-priming and are equipped with Viton® seals with carbon and Ni-resist faces capable of handling liquids with temperatures to 160° F. Maximum flow to 128 GPM and max operating pressure to 31 PSI.

Exp. Proof Classes: Class 1, Group D,  
Class 2, Groups E,F,G or FG.

## PREMIUM HEAVY DUTY



**Model 02C3-X1.5 1P**

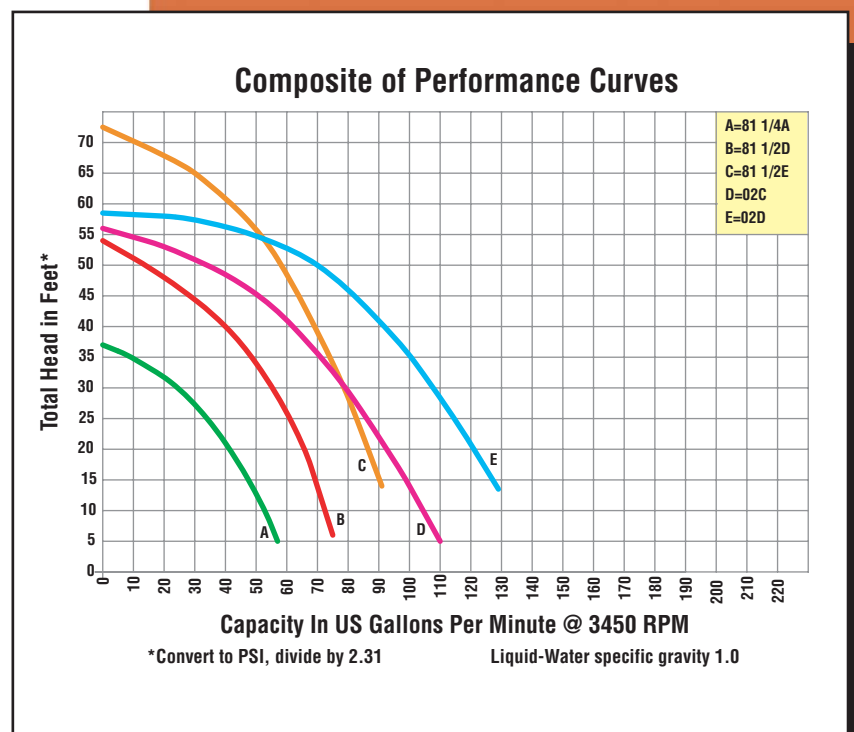

\*Viton® is a registered trademark of DuPont

# Self-Priming Centrifugal Pumps

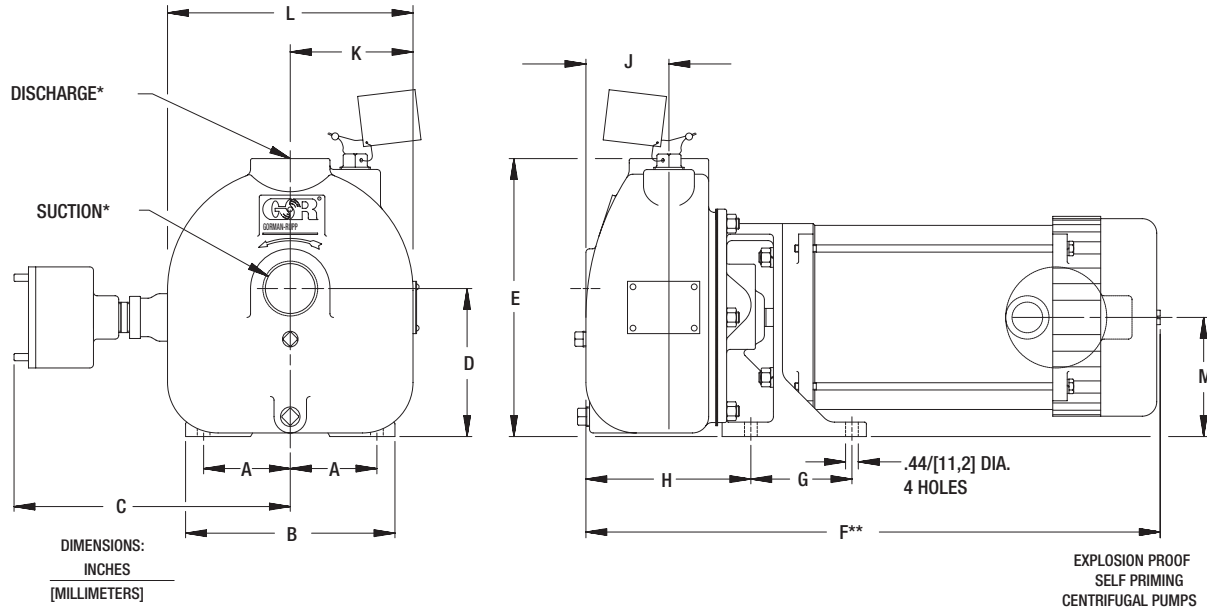

MODEL	CURVE	A	B	C	D	E	F**	G	H	J	K	L	M	SUCT*	DISCH*
81 1/4A3-X.50 1P	A	3.50 [88.9]	8.00 [203.2]	9.56 [242.8]	4.75 [120.6]	8.00 [203.2]	18.00 [457.2]	3.00 [76.2]	5.62 [142.7]	3.19 [81.0]	3.44 [87.4]	6.88 [174.8]	3.50 [88.9]	1.25	1.25
81 1/4A3-X.50 3P	A	3.50 [88.9]	8.00 [203.2]	9.56 [242.8]	4.75 [120.6]	8.00 [203.2]	18.00 [457.2]	3.00 [76.2]	5.62 [142.7]	3.19 [81.0]	3.44 [87.4]	6.88 [174.8]	3.50 [88.9]	1.25	1.25
81 1/2D3-X1 1P	B	3.00 [76.2]	7.00 [177.8]	9.56 [242.8]	5.12 [130.0]	9.63 [244.6]	20.00 [508.0]	3.50 [88.9]	5.71 [145.0]	2.88 [73.2]	4.25 [108.0]	8.50 [215.9]	4.13 [104.9]	1.50	1.50
81 1/2D3-X1 3P	B	3.00 [76.2]	7.00 [177.8]	9.56 [242.8]	5.12 [130.0]	9.63 [244.6]	20.00 [508.0]	3.50 [88.9]	5.71 [145.0]	2.88 [73.2]	4.25 [108.0]	8.50 [215.9]	4.13 [104.9]	1.50	1.50
81 1/2E3-X1.5 1P	C	3.50 [76.2]	7.24 [183.9]	9.56 [242.8]	5.12 [130.0]	9.63 [244.6]	21.00 [533.4]	3.50 [88.9]	5.69 [144.5]	2.88 [73.2]	4.25 [108.0]	8.50 [215.9]	4.13 [104.9]	1.50	1.50
81 1/2E3-X1.5 3P	C	3.50 [76.2]	7.24 [183.9]	9.56 [242.8]	5.12 [130.0]	9.63 [244.6]	21.00 [533.4]	3.50 [88.9]	5.69 [144.5]	2.88 [73.2]	4.25 [108.0]	8.50 [215.9]	4.13 [104.9]	1.50	1.50
02C3-X1.5 1P	D	2.88 [73.2]	7.00 [177.8]	N/A	6.62 [168.1]	10.88 [276.4]	21.00 [533.4]	3.50 [88.9]	5.81 [147.6]	2.88 [73.2]	4.88 [123.9]	9.75 [247.6]	5.38 [136.6]	2.00	2.00
02C3-X1.5 3P	D	2.88 [73.2]	7.00 [177.8]	N/A	6.62 [168.1]	10.88 [276.4]	21.00 [533.4]	3.50 [88.9]	5.81 [147.6]	2.88 [73.2]	4.88 [123.9]	9.75 [247.6]	5.38 [136.6]	2.00	2.00
02D3-X2 1P	E	2.88 [73.2]	7.00 [177.8]	N/A	6.62 [168.1]	10.88 [276.4]	21.00 [533.4]	3.50 [88.9]	5.81 [147.6]	2.88 [73.2]	4.88 [123.9]	9.75 [247.6]	5.38 [136.6]	2.00	2.00
02D3-X2 3P	E	2.88 [73.2]	7.00 [177.8]	N/A	6.62 [168.1]	10.88 [276.4]	21.00 [533.4]	3.50 [88.9]	5.81 [147.6]	2.88 [73.2]	4.88 [123.9]	9.75 [247.6]	5.38 [136.6]	2.00	2.00

(\*) STANDARD NPT PIPE THREADS.

(\*\*) DIMENSION MAY VARY WITH MOTOR MANUFACTURER.

Model No.	Description/ Type of Pump	Ship Wt (Lbs.)	Driver Type & HP	Port size Suc x dis (NPT)	Basic Construc- tion	Seal Type & Elastomer/ Faces	VAC	Cycle	Motor Enclosure
81 1/4A3-X.50 1P	Explosion Proof Self-Priming Centrifugal Pumps	85	Elect. Motor 0.5 HP	1 1/4" x 1 1/4"	Gray Iron	Viton®* Carbon Ni-resist	115/230	60 Cycle	X-Proof
81 1/4A3-X.50 3P	Explosion Proof Self-Priming Centrifugal Pumps	85	Elect. Motor 0.5 HP	1 1/4" x 1 1/4"	Gray Iron	Viton®* Carbon Ni-resist	230/460	60 Cycle	X-Proof
81 1/2D3-X1 1P	Explosion Proof Self-Priming Centrifugal Pumps	89	Elect. Motor 1.0 HP	1 1/2" x 1 1/2"	Gray Iron	Viton®* Carbon Ni-resist	115/230	60 Cycle	X-Proof
81 1/2D3-X1 3P	Explosion Proof Self-Priming Centrifugal Pumps	89	Elect. Motor 1.0 HP	1 1/2" x 1 1/2"	Gray Iron	Viton®* Carbon Ni-resist	208/230/460	60 Cycle	X-Proof
81 1/2E3-X1.5 1P	Explosion Proof Self-Priming Centrifugal Pumps	76	Elect. Motor 1.5 HP	1 1/2" x 1 1/2"	Gray Iron	Viton®* Carbon Ni-resist	115/230	60 Cycle	X-Proof
81 1/2E3-X1.5 3P	Explosion Proof Self-Priming Centrifugal Pumps	76	Elect. Motor 1.5 HP	1 1/2" x 1 1/2"	Gray Iron	Viton®* Carbon Ni-resist	230/460	60 Cycle	X-Proof
02C3-X1.5 1P	Explosion Proof Self-Priming Centrifugal Pumps	99	Elect. Motor 1.5 HP	2" x 2"	Gray Iron	Viton®* Carbon Ni-resist	115/230	60 Cycle	X-Proof
02C3-X1.5 3P	Explosion Proof Self-Priming Centrifugal Pumps	99	Elect. Motor 1.5 HP	2" x 2"	Gray Iron	Viton®* Carbon Ni-resist	230/460	60 Cycle	X-Proof
02D3-X2 1P	Explosion Proof Self-Priming Centrifugal Pumps	101	Elect. Motor 2 HP	2" x 2"	Gray Iron	Viton®* Carbon Ni-resist	115/230	60 Cycle	X-Proof
02D3-X2 3P	Explosion Proof Self-Priming Centrifugal Pumps	101	Elect. Motor 2 HP	2" x 2"	Gray Iron	Viton®* Carbon Ni-resist	230/460	60 Cycle	X-Proof

\*Viton® is a registered trademark of DuPont

## Standard Features

- Cast iron construction
- Maximum operating pressure to 31 PSI
- Solids handling to 3/8" diameter
- Viton® seals with carbon and Ni-resist faces
- Maximum temperature 160° F
- Self-priming to 20 ft.
- 1-1/4", 1-1/2" & 2" NPT port sizes
- Maximum flow 128 GPM
- 1/2 to 2 HP single to three (3) phase 3450 RPM motors
- Maximum head 72 ft.

See price book page 20

The Gorman-Rupp Company reserves the right to discontinue any model or change specifications at any time without incurring any obligation.

CP49-50/0904

