

Series P55-5100/P56-5100

Triplex Ceramic
Plunger Pump
Operating Instructions/
Repair and Service
Manual

316 Stainless Steel Pumps

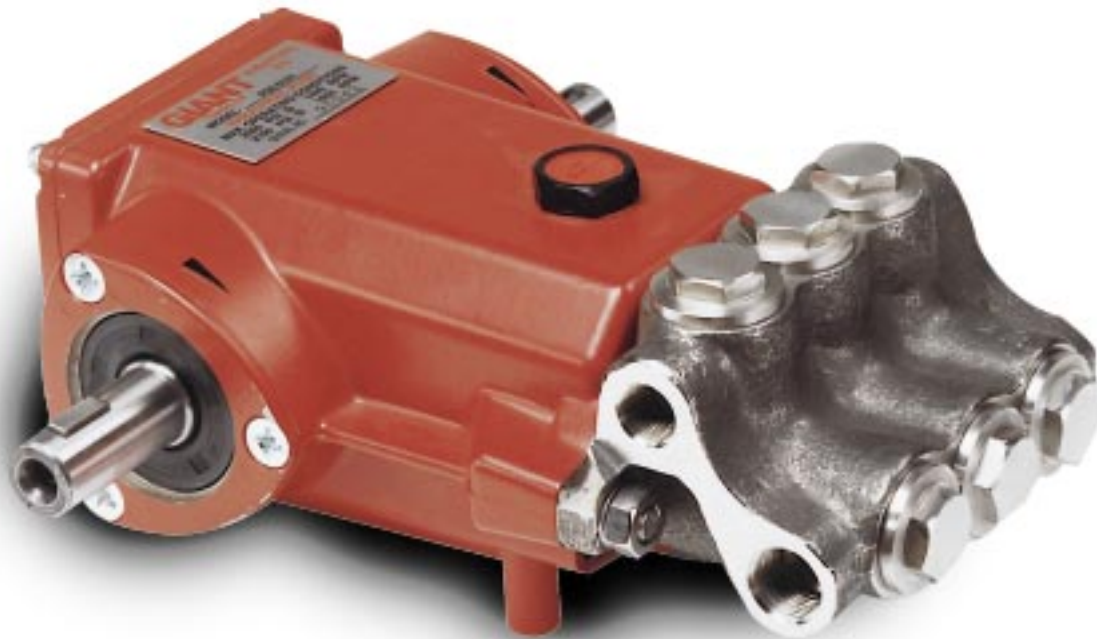

GIANT

Contents:

Installation Instructions:	page 2
P55-5100 Specifications:	page 3
Exploded View:	page 4
Parts List:	page 5
P56-5100/P56-5121 Specifications:	page 6
Repair Instructions:	page 7
Torque Specifications:	page 7
Dimensions:	back page
Warranty Information:	back page

Updated 7/02

INSTALLATION INSTRUCTIONS

Installation of the Giant Industries, Inc., pump is not a complicated procedure, but there are some basic steps common to all pumps. The following information is to be considered as a general outline for installation. If you have unique requirements, please contact Giant Industries, Inc. or your local distributor for assistance.

1. The pump should be installed flat on a base to a maximum of a 15 degree angle of inclination to ensure optimum lubrication.
2. The inlet to the pump should be sized for the flow rate of the pump with no unnecessary restrictions that can cause cavitation. Teflon tape should be used to seal all joints. If pumps are to be operated at temperatures in excess of 160° F, it is important to insure a positive head to the pump to prevent cavitation.
3. The discharge plumbing from the pump should be properly sized to the flow rate to prevent line pressure loss to the work area. It is essential to provide a safety bypass valve between the pump and the work area to protect the pump from pressure spikes in the event of a blockage or the use of a shut-off gun.
4. Use of a dampener is necessary to minimize pulsation at drive elements, plumbing, connections, and other system areas. The use of a dampener with Giant Industries, Inc. pumps is optional, although

recommended by Giant Industries, Inc. to further reduce system pulsation. Dampeners can also reduce the severity of pressure spikes that occur in systems using a shut-off gun. A dampener must be positioned downstream from the unloader.

5. Crankshaft rotation on Giant Industries, Inc. pumps should be made in the direction designated by the arrows on the pump crankcase. Reverse rotation may be safely achieved by following a few guidelines available upon request from Giant Industries, Inc. Required horsepower for system operation can be obtained from the charts on pages 3.
6. Before beginning operation of your pumping system, remember: Check that the crankcase and seal areas have been properly lubricated per recommended schedules. Do not run the pump dry for extended periods of time. Cavitation will result in severe damage. Always remember to check that all plumbing valves are open and that pumped media can flow freely to the inlet of the pump.

Finally, remember that high pressure operation in a pump system has many advantages. But, if it is used carelessly and without regard to its potential hazard, it can cause serious injury.

IMPORTANT OPERATING CONDITIONS Failure to comply with any of these conditions invalidates the warranty

1. Prior to initial operation, add oil to crankcase so that the oil level is between the two lines on the oil dipstick. DO NOT OVERFILL. **Giant Industries oil or the equivalent (20W-50) Kendall GT 1 oil.** Crankcase oil should be changed after the first 50 hours of operation, then at regular intervals of 500 hours or less depending on operating conditions.

2. Pump operation must not exceed rated pressure, volume, or RPM. A pressure relief device must be installed in the discharge of the system.

3. Acids, alkalines, or abrasive fluids cannot be pumped unless approval in writing is obtained before operation from Giant Industries, Inc.

4. Run the pump dry approximately 10 seconds to drain the water before exposure to freezing temperatures.

NOTE: Contact Giant Industries for Service School Information. Phone: (419)-531-4600.

Specifications

Models P55-5100

Ratings (Continuous) (P55-5100)	4.9 GPM @ 2320 PSI @ 1420 RPM
Ratings (Intermittent) (P55-5100)	6.0 GPM @ 1000 PSI @ 1750 RPM
Inlet Pressure	Up to 90 PSI
Plunger Diameter	18mm
Stroke	18.1mm
Crankcase Oil Capacity	14 fl.oz.
Temperature of Pumped Fluids	Up to 160 °F
Inlet Ports	(2) 1/2" BSP
Discharge Ports	(2) 3/8" BSP
Crankshaft Mounting	Either
Shaft Rotation	Top of Pulley Towards Fluid End
Weight	18 lbs.
Crankshaft Diameter	24mm
Volumetric Efficiency @ 1420 RPM	0.94
Mechanical Efficiency @ 1420 RPM	0.86

PULLEY INFORMATION

Pulley selection and pump speed are based on a 1725 RPM motor and "B" section belts. When selecting desired GPM, allow for a ±5% tolerance on pumps output due to variations in pulleys, belts and motors among manufacturers.

1. Select GPM required, then select appropriate motor and pump pulley from the same line.
2. The desired pressure is achieved by selecting the correct nozzle size that corresponds with the pump GPM.

HORSEPOWER INFORMATION

Horsepower ratings shown are the power requirements for the pump. Gas engine power outputs must be approximately twice the pump power requirements shown above.

We recommend that a 1.1 service factor be specified when selecting an electric motor as the power source. To compute specific pump horsepower requirements, use the following formula:

$$\frac{\text{GPM} \times \text{PSI}}{1460} = \text{hp}$$

Consult the factory for special requirements that must be met if the pump is to operate beyond one or more of the limits specified above.

P55-5100 PULLEY SELECTION & HORSEPOWER REQUIREMENTS							
PUMP PULLEY	MOTOR PULLEY	RPM	GPM	500 PSI	1000 PSI	2000 PSI	2320 PSI
7.75"	4.00"	851	2.9	1.0	2.0	4.0	4.6
7.75"	4.50"	967	3.3	1.1	2.3	4.5	5.2
7.75"	5.00"	1084	3.7	1.3	2.5	5.1	5.9
7.75"	5.50"	1201	4.1	1.4	2.8	5.6	6.5
7.75"	6.00"	1317	4.5	1.5	3.1	6.2	7.2
7.75"	6.45"	1420	4.9	1.7	3.4	6.7	7.8
7.75"	7.75"	1750	6.0	2.1	4.1		

Exploded View - P55-5100/P56-5100 Series

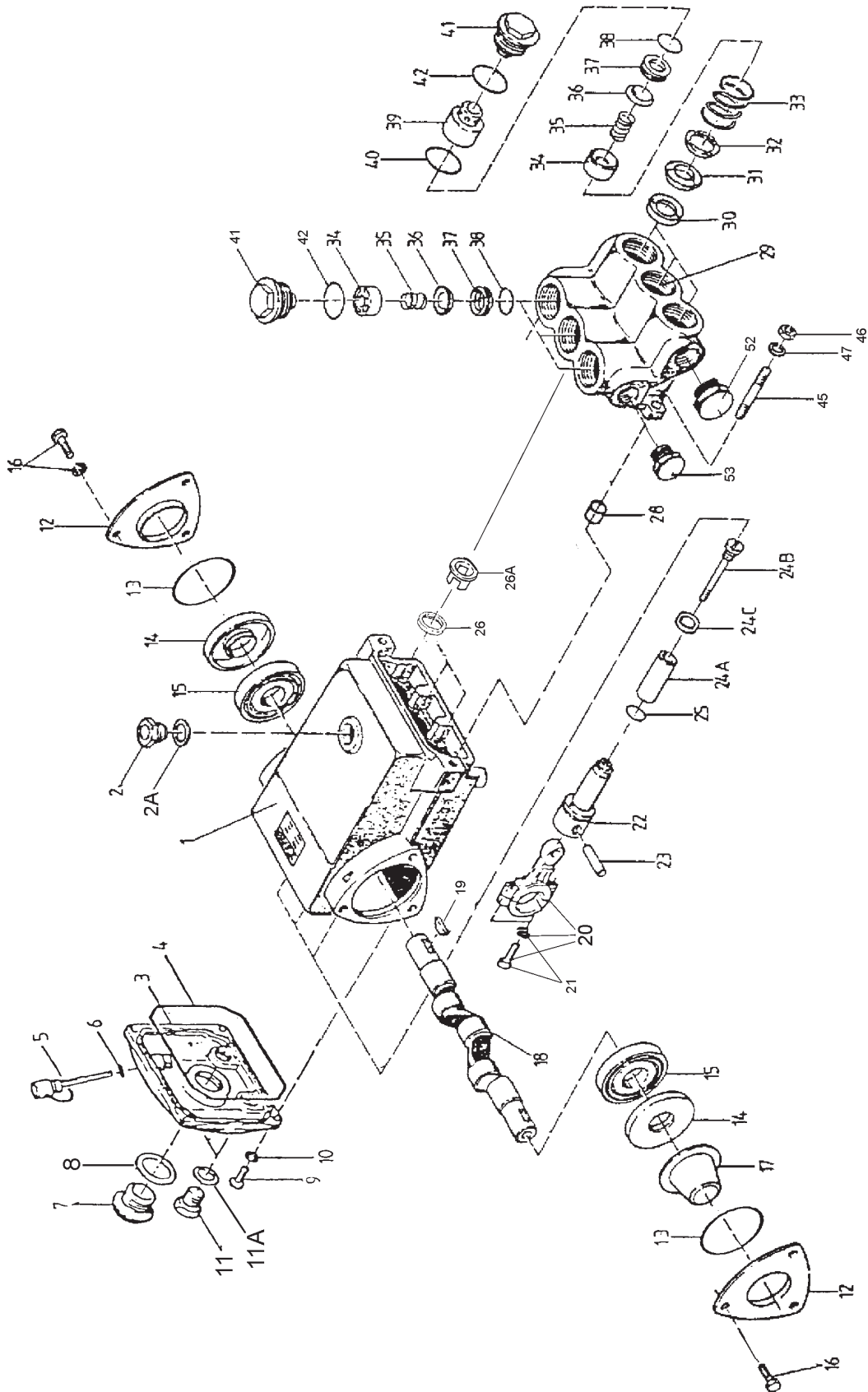

P55-5100/P56-5100 SERIES PARTS LIST

<u>ITEM</u>	<u>PART</u>	<u>DESCRIPTION</u>	<u>QTY.</u>	<u>ITEM</u>	<u>PART</u>	<u>DESCRIPTION</u>	<u>QTY.</u>
1	07180	Crankcase	1	24A	06066	Ceramic Plunger (P56-5100)	3
2	07181	Oil Filler Cap	1	24B	07023-0100	Bolt	3
2A	07182	Gasket, Oil Filler Cap	1	24C	07204-0100	Ring	3
3	07183	Cover, Crankcase	1	26	07206	Crankcase Oil Seal	3
4	07184	O-Ring, Crankcase Cover	1	26A	13346	Oil Seal Retainer	3
5	07185	Oil Dip Stick	1	28	07207	Shim, Manifold Stud	2
6	01009	O-Ring, Dip Stick	1	29	07369-5000	Manifold Head	1
7	07186	Oil Sight Glass	1	30	06947	Pressure Ring (P55-5100)	3
8	07187	Gasket, Oil Sight Glass	1	30	07221-0100	Pressure Ring (P56-5100)	3
9	07188	Screw, Crankcase Cover	4	31	06064-0010	V-Sleeve	3
10	07189	Spring Washer	4	31	06064-0020	V-Sleeve	3
11	07190	Oil Drain Plug	2	32	06948	Support Ring (P55-5100)	3
11A	07191	Gasket, Oil Drain Plug	2	32	07029-0100	Support Ring (P56-5100)	3
12	07192	Bearing Cover	2	33	07210-0100	Pressure Spring	3
13	07193	O-Ring, Bearing Cover	2	34	06018-0100	Retainer, Spring	6
14	01166	Radial Shaft Seal	2	35	06017-0100	Valve Spring	6
15	01086	Ball Bearing	2	36	06016-0100	Valve Plate	6
16	07196	Screw, Bearing Cover	6	37	06014-0100	Valve Seat	6
17	07197	Shaft Protector	1	38	06015-0001	O-Ring, Valve Seat	6
18	07198	Crankshaft	1	39	07211-0100	Adapter, Inlet Valve	3
19	01024	Key	1	40	07212-0001	O-Ring, Adapter	3
20	07199	Connecting Rod w/ Screws	3	41	07213-0100	Plug, Manifold	3
21	01027	Conn. Rod Screw		42	07214-0001	O-Ring, Manifold Plug	3
		w/ Washer	6	45	07215	Stud, Manifold	4
22	07201	Plunger Base		46	08040-0100	Hex Nut, Manifold Stud	4
		w/ S.S. Crosshead	3	47	08041	Spring Washer, Stud	4
25	07205	Flinger	3	52	12250	Inlet Plug	1
23	01031	Crosshead Pin	3	53	12138	Outlet Plug	1
24A	07021	Ceramic Plunger (P55-5100)	3				

Specifications

P56-5111 & P56-5121

Ratings (Continuous)	6.1 GPM @ 1900 PSI @ 1420 RPM
Ratings (Intermittent)	6.1 GPM @ 2200 PSI @ 1420 RPM
Ratings (Intermittent)	7.5 GPM @ 1000 PSI @ 1750 RPM
Inlet Pressure	Up to 90 PSI
Plunger Diameter	20mm
Stroke	18.1mm
Crankcase Oil Capacity	14 fl.oz.
Temperature of Pumped Fluids	Up to 160 °F
Inlet Ports	(2) 1/2" BSP
Discharge Ports	(2) 3/8" BSP
Crankshaft Mounting	Either
Shaft Rotation	Top of Pulley Towards Fluid End
Weight	18 lbs.
Crankshaft Diameter	24mm
Volumetric Efficiency @ 1420 RPM	0.94
Mechanical Efficiency @ 1420 RPM	0.86

PULLEY INFORMATION

Pulley selection and pump speed are based on a 1725 RPM motor and "B" section belts. When selecting desired GPM, allow for a ±5% tolerance on pumps output due to variations in pulleys, belts and motors among manufacturers.

1. Select GPM required, then select appropriate motor and pump pulley from the same line.
2. The desired pressure is achieved by selecting the correct nozzle size that corresponds with the pump GPM.

HORSEPOWER INFORMATION

Horsepower ratings shown are the power requirements for the pump. Gas engine power outputs must be approximately twice the pump power requirements shown above.

We recommend that a 1.1 service factor be specified when selecting an electric motor as the power source. To compute specific pump horsepower requirements, use the following formula:

$$\frac{\text{GPM} \times \text{PSI}}{1460} = \text{hp}$$

Consult the factory for special requirements that must be met if the pump is to operate beyond one or more of the limits specified above.

P56-5111 & P56-5121 PULLEY SELECTION & HORSEPOWER REQUIREMENTS								
PUMP PULLEY	MOTOR PULLEY	RPM	GPM	500 PSI	1000 PSI	1500 PSI	1900 PSI	2200* PSI
7.75"	4.00"	851	3.7	1.3	2.5	3.8	4.8	5.6
7.75"	4.50"	967	4.2	1.4	2.9	4.3	5.5	6.3
7.75"	5.00"	1084	4.7	1.6	3.2	4.8	6.1	7.1
7.75"	5.50"	1201	5.2	1.8	3.6	5.3	6.8	7.8
7.75"	6.00"	1317	5.7	2.0	3.9	5.9	7.4	8.6
7.75"	6.45"	1420	6.1	2.1	4.2	6.3	7.9	9.2
7.75"	7.75"	1750*	7.5	2.6	5.1			

REPAIR INSTRUCTION - P55-5100/P56-5100 SERIES

To Check Suction and Discharge Valves

Remove the plugs (41) with a socket wrench. Examine the valves, which lie underneath, thoroughly. Only the spring retainer has to be removed on the pressure side. On the inlet side, take out the suction valve adaptor (39) with flat pliers and remove the spring retainer (34). Examine the valve plates (36) and valve seats (37) for wear and pitting. If necessary, replace and reassemble in correct sequence.

To Check V-Sleeves

Loosen stud nuts (46) and separate the valve casing (29) from the crankcase (1). Remove the inlet valve plugs (41). Next take out the inlet valve assembly. Remove the v-sleeves (31), support rings (32) and pressure rings (30) from the back of the manifold. Grease new v-sleeves (31). Check surfaces of plunger pipes as damaged surfaces cause fast wear to v-sleeves. Lime deposits (etc.) can be removed with fine sand paper. When reassembling, tighten stud nuts to 35 ft.-lbs.

To Check Plungers and Gear

If oil leaks where the plungers (22) protrude, the oil seal (26) and worn plunger with crosshead (22) must be replaced. To do this, drain oil and remove crankcase cover (3) and valve casing (29) and oil seal retainer (26A). Remove screws (21) on connecting rod (20). Do not mix up cup halves belonging to each other. Take note of the numbers on the shaft and on the connecting rod. Push stem of connecting rod as far as possible into the crosshead guide. Loosen bearing cover screws (16) and push out crankshaft (18). Dismantle crosshead and connecting rod by pressing out the crosshead pin (23). Push oil seal out from the back of the crankcase (1). Clean surfaces thoroughly. Put Loctite on new oil seals and place in crankcase. Make sure that the oil seals are flush with the crankcase and are not cantered.

To Replace Plunger Pipes

Screw out tension screws (24B), and pull off plunger pipe (24A). Check and clean plunger surface and replace with a new plunger pipe. Check oil seals (27). Fasten tension screws with a liquid glue and tighten carefully to 106 in.-lbs.

P55-5100/P56-5100 SERIES TORQUE SPECIFICATIONS

<u>Position</u>	<u>Item#</u>	<u>Description</u>	<u>Torque Amount</u>
24B	07023-0100	Tension Screw, Plunger	106 in.-lbs.
46	08040-0100	Stud Nuts	35 ft.-lbs.

P55-5100/P56-5100 DIMENSIONS

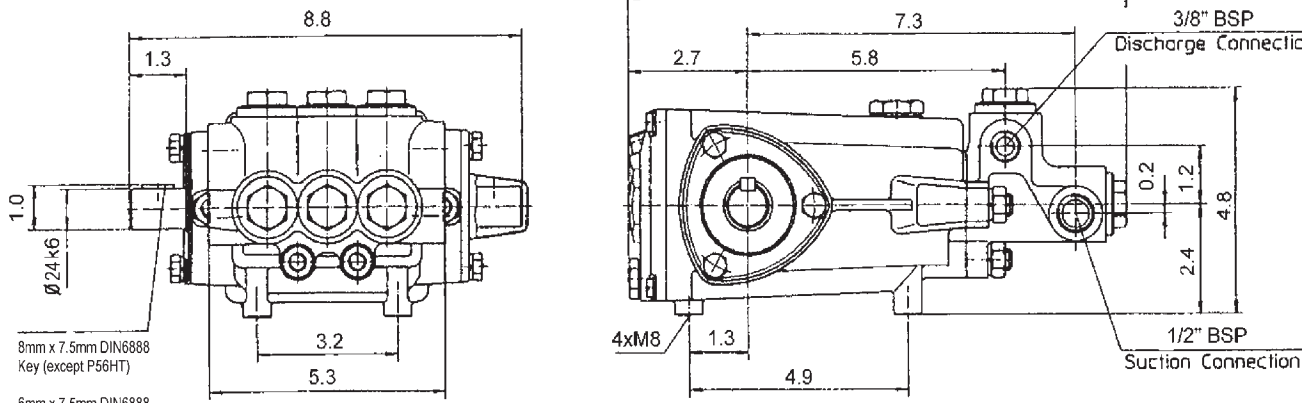

GIANT INDUSTRIES LIMITED WARRANTY

Giant Industries, Inc. pumps and accessories are warranted by the manufacturer to be free from defects in workmanship and material as follows:

1. For portable pressure washers and car wash applications, the discharge manifolds will never fail, period. If they ever fail, we will replace them free of charge. Our other pump parts, used in portable pressure washers and in car wash applications, are warranted for five years from the date of shipment for all pumps used in NON-SALINE, clean water applications.
2. One (1) year from the date of shipment for all other Giant industrial and consumer pumps.
3. Six (6) months from the date of shipment for all rebuilt pumps.
4. Ninety (90) days from the date of shipment for all Giant accessories.

This warranty is limited to repair or replacement of pumps and accessories of which the manufacturer's evaluation shows were defective at the time of shipment by the manufacturer. The following items are NOT covered or will void the warranty:

1. Defects caused by negligence or fault of the buyer or third party.
2. Normal wear and tear to standard wear parts.
3. Use of repair parts other than those manufactured or authorized by Giant.
4. Improper use of the product as a component part.
5. Changes or modifications made by the customer or third party.
6. The operation of pumps and or accessories exceeding the specifications set forth in the Operations Manuals provided by Giant Industries, Inc.

Liability under this warranty is on all non-wear parts and limited to the replacement or repair of those products returned freight prepaid to Giant Industries which are deemed to be defective due to workmanship or failure of material. A Returned Goods Authorization (R.G.A.) number and completed warranty evaluation form is required prior to the return to Giant Industries of all products under warranty consideration. Call (419)-531-4600 or fax (419)-531-6836 to obtain an R.G.A. number.

Repair or replacement of defective products as provided is the sole and exclusive remedy provided hereunder and the MANUFACTURER SHALL NOT BE LIABLE FOR FURTHER LOSS, DAMAGES, OR EXPENSES, INCLUDING INCIDENTAL AND CONSEQUENTIAL DAMAGES DIRECTLY OR INDIRECTLY ARISING FROM THE SALE OR USE OF THIS PRODUCT.

THE LIMITED WARRANTY SET FORTH HEREIN IS IN LIEU OF ALL OTHER WARRANTIES OR REPRESENTATION, EXPRESS OR IMPLIED, INCLUDING WITHOUT LIMITATION ANY WARRANTIES OR MERCHANTABILITY OR FITNESS FOR A PARTICULAR PURPOSE AND ALL SUCH WARRANTIES ARE HEREBY DISCLAIMED AND EXCLUDED BY THE MANUFACTURER.

