

Model LP700

Triplex Ceramic
Plunger Pump
Operating Instructions/
Repair and Service
Manual

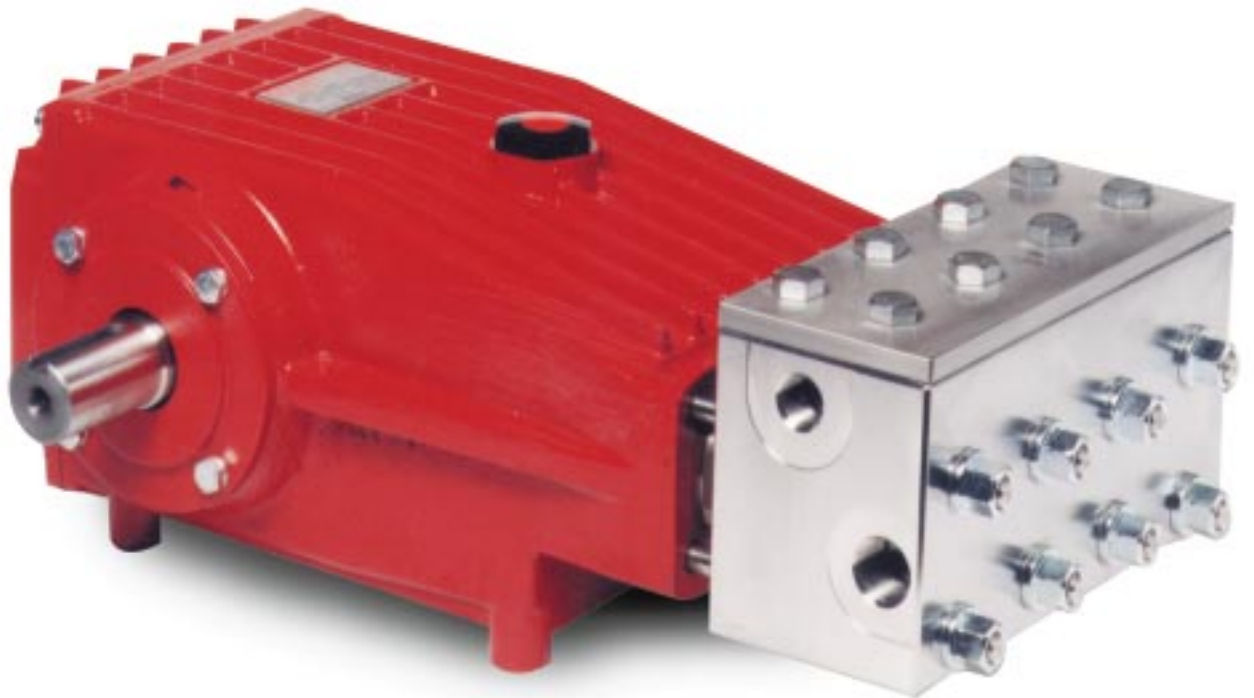

GIANT

Contents:

Installation Instructions:	page 2
Pump Specifications:	page 3
Exploded View:	page 4
Parts, Kits, Torque:	page 5
Repair Instructions:	page 6
Dimensions:	page 7
Warranty Information:	back page

INSTALLATION INSTRUCTIONS

Installation of the Giant Industries, Inc., pump is not a complicated procedure, but there are some basic steps common to all pumps. The following information is to be considered as a general outline for installation. If you have unique requirements, please contact Giant Industries, Inc. or your local distributor for assistance.

1. The pump should be installed flat on a base to a maximum of a 15 degree angle of inclination to ensure optimum lubrication.
2. The inlet to the pump should be sized for the flow rate of the pump with no unnecessary restrictions that can cause cavitation. Teflon tape should be used to seal all joints. If pumps are to be operated at temperatures in excess of 104° F, it is important to insure a positive head to the pump to prevent cavitation.
3. The discharge plumbing from the pump should be properly sized to the flow rate to prevent line pressure loss to the work area. It is essential to provide a safety bypass valve between the pump and the work area to protect the pump from pressure spikes in the event of a blockage or the use of a shut-off gun.

4. Use of a dampener is necessary to minimize pulsation at drive elements, plumbing, connections, and other system areas. The use of a dampener with Giant Industries, Inc. pumps is optional, although recommended by Giant Industries, Inc. to further reduce system pulsation. Dampeners can also reduce the severity of pressure spikes that occur in systems using a shut-off gun. A dampener must be positioned downstream from the unloader.

5. Crankshaft rotation on Giant Industries, Inc. pumps should be made in the direction designated by the arrows on the pump crankcase. Reverse rotation may be safely achieved by following a few guidelines available upon request from Giant Industries, Inc. Required horsepower for system operation can be obtained from the chart on page 3.

6. Before beginning operation of your pumping system, remember: Check that the crankcase and seal areas have been properly lubricated per recommended schedules. Do not run the pump dry for extended periods of time. Cavitation will result in severe damage. Always remember to check that all plumbing valves are open and that pumped media can flow freely to the inlet of the pump.

Finally, remember that high pressure operation in a pump system has many advantages. But, if it is used carelessly and without regard to its potential hazard, it can cause serious injury.

IMPORTANT OPERATING CONDITIONS

Failure to comply with any of these conditions invalidates the warranty.

1. Prior to initial operation, add oil to the crankcase so that oil level is between the two lines on the oil dipstick. **DO NOT OVERFILL.**

Use SAE 90 Industrial gear oil.

Crankcase oil should be changed after the first 50 hours of operation, then at regular intervals of 500 hours or less depending on operating conditions.

2. Pump operation must not exceed rated pressure, volume, or RPM. A pressure relief device must be installed in the discharge of the system.

3. Acids, alkalines, or abrasive fluids cannot be pumped unless approval in writing is obtained before operation from Giant Industries, Inc.

4. Run the pump dry approximately 10 seconds to drain the water before exposure to freezing temperatures.

Specifications Model LP700 High-Pressure Plunger Pump

Volume	7.9 GPM
Maximum Discharge Pressure	7250 PSI
Maximum Inlet Pressure	Up to 90 PSIG ¹
RPM	1000
Plunger Diameter	18mm
Stroke	42mm
Crankcase Oil Capacity	102 fl. oz.
Temperature of Pumped Fluids	Up to 104 °F
Inlet Port	2 x 3/4" NPT
Discharge Ports	2 x 1/2" NPT
Shaft Rotation	Either Direction ²
Weight	173 lbs.
Width	20.9"
Height	7.9"

LP700 HORSEPOWER CHART					
RPM	GPM	3000 PSI	5000 PSI	6000 PSI	7250 PSI
500	3.9	8.1	13.5	16.3	19.6
600	4.7	9.8	16.3	19.6	23.7
700	5.3	11.0	18.4	22.1	26.7
800	6.3	13.1	21.9	26.3	31.7
900	7.1	14.8	24.7	29.6	35.7
1000	7.9	16.5	27.4	32.9	39.8

HORSEPOWER RATINGS:

The rating shown are the power requirements for the pump. Gas engine power outputs must be approximately twice the pump power requirements shown above.

We recommend a 1.15 service factor be specified when selecting an electric motor as the power source. To compute specific pump horsepower requirements, use the Following formula:

$$HP = (GPM \times PSI) / 1440$$

LP700 EXPLODED VIEW

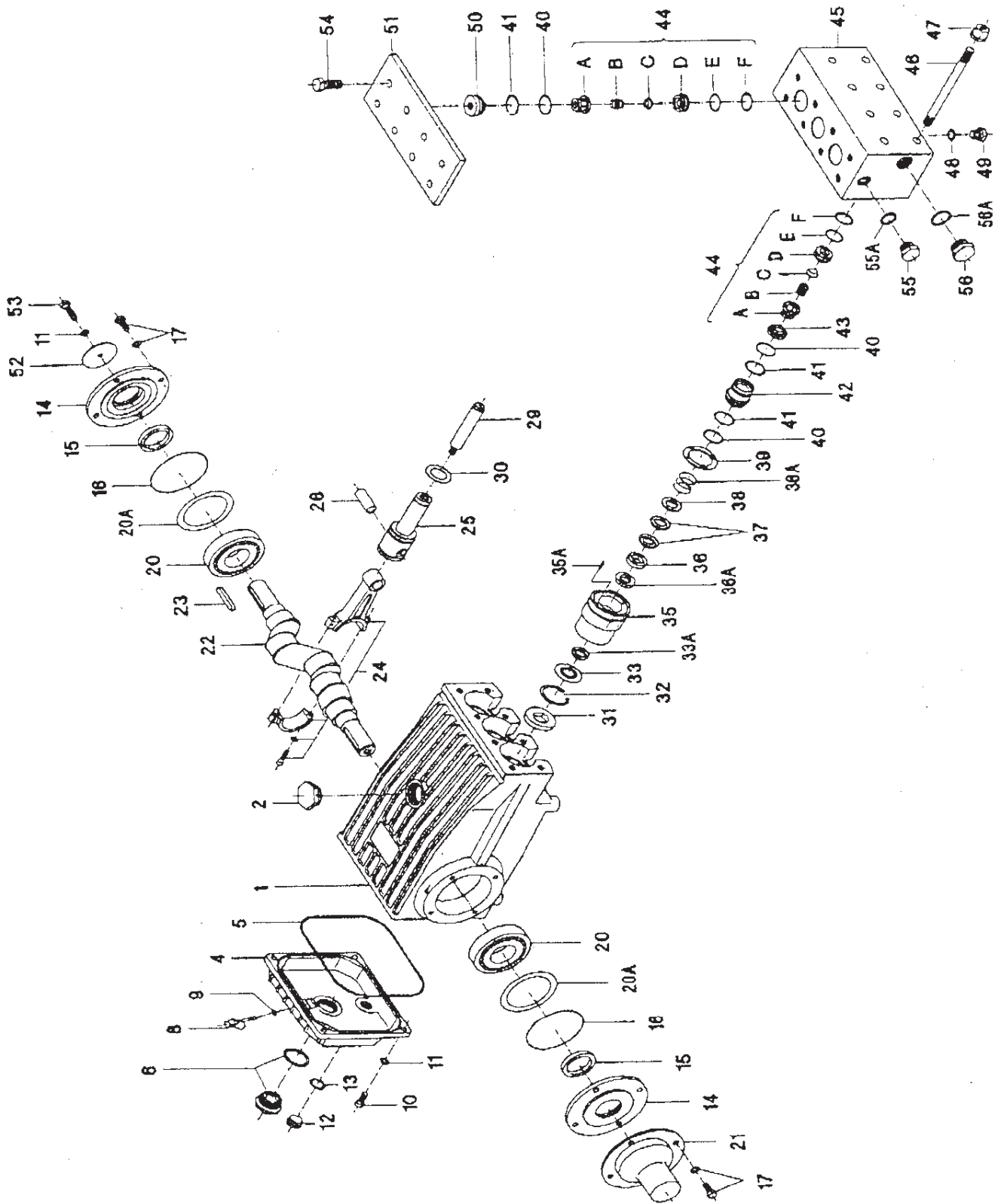

Model LP700 - PARTS LIST

<u>ITEM#</u>	<u>PART #</u>	<u>DESCRIPTION</u>	<u>QTY</u>	<u>ITEM#</u>	<u>PART #</u>	<u>DESCRIPTION</u>	<u>QTY</u>
1	07759	Crankcase	1	35A	22764	Lock Pin	3
2	13000	Oil Filler Plug Assy	1	36	06359	Pressure Ring	3
4	06085	Crankcase Cover	1	36A	13421	Guide Ring	3
5	07104	O-Ring	1	37	06360	Sleeve	3
6	07186	Oil Sight Glass	1	38	13422	Sleeve Support Ring	3
8	06086	Oil Dipstick Assy	1	38A	13423	Spring	3
9	01009	O-Ring	1	39	13424	Leakage Seal	3
10	01010	Cylinder Screw	4	40	07214	O-Ring	9
11	01011	Spring Ring	5	41	06361	Support Ring	9
12	07109	Plug 1/2"	1	42	13425	Seal Case	3
13	07182	Gasket	1	43	13426	Valve Retainer	3
14	07111	Bearing Cover	2	44A	06362	Spring Tension Cap	6
15	07112	Radial Shaft Seal	2	44B	07283	Valve Spring	6
16	07113	O-Ring	2	44C	06363	Valve Plate	6
17	07114	Hexagon Screw	8	44D	06364	Valve Seat	6
20	07116	Taper Roller Bearing	2	44E	07035	O-Ring	6
20A	07117	Fitting Disc	1-3	44F	13427	Support Ring	6
20B	13001	Fitting Disc	1	45	13428	Valve Casing	1
21	07118	Shaft Protector	1	46	13429	Stud Bolt	8
22	13242	Crankshaft	1	47	13430	Hexagon Nut	8
23	13243	Fitting Key	1	48	07161	Copper Washer	3
24	13340	Connecting Rod Assy	3	49	13261	Plug 1/4"	3
25	13341	Crosshead/Plinger Assy	3	50	13431	Plug	3
28	13232	Crosshead Pin	3	51	13432	Cover for Valve Casing	1
29	06366	Plunger	3	52	13020	Disc for Crankshaft	1
30	07779	Oil Scraper	3	53	13021	Hexagon Screw	1
31	07133	Radial Shaft Seal	3	54	13433	Hexagon Screw	8
32	13418	Clip Ring	3	55	13434	Plug 1/2"	1
33	13419	Support Disc	3	55A	06272	Copper Washer	1
33A	08087	Grooved Ring	3	56	07703	Plug 1/2"	1
35	13420	Seal Sleeve	3	56A	07704	Copper Washer	1

LP700 KITS

Packing Kit

#09490

<u>Qty</u>	<u>Part #</u>	<u>Description</u>
3	08087	V-Sleeve
3	06359	Pressure Ring
6	06360	V-Sleeve
3	13424	Leakage Seal

Valve Assembly

#09491

<u>Qty</u>	<u>Part #</u>	<u>Description</u>
9	07214	O-Ring
9	06361	Support Ring
6	06362	Tension Ring
6	07283	Valve Spring
6	06363	Valve Plate
6	06364	Valve Seat
6	07035	O-Ring
6	13427	Support Ring

TORQUE SPECIFICATIONS

<u>Position</u>	<u>Description</u>	<u>Torque Amount</u>
24	Connecting Rod	264 in.-lbs.
29	Plunger	22 ft.-lbs.
54	Hexagon Screws	59 ft.-lbs.

REPAIR INSTRUCTIONS - Model LP700

VALVEREPLACEMENT

- 1) **Discharge Valves:** Screw out 8 x hexagon screw (54), remove cover (51). Screw hexagon screw (54) into thread of plug (50) and pull out plug. Using a clipping pliers, remove spring tension cup (44A) and valve seat (44D). If necessary, use a dia 12 pull-out tool to remove valve seat. Check parts, and replace if worn.
- 2) Check O-rings (40/44E) and support rings (41/44F) and replace as necessary.
- 3) Tighten hexagon screws (54) TO 59 ft. lbs.
- 4) **Suction Valves:** Unscrew 8 x nut (47), remove valve casing (45) from seal sleeves (42). Using two screwdrivers, lever out seal case (42) from valve casing. Remove Spring tension cup (44A) and valve seat (44D) with a clipping pliers. If necessary, use a dia 12 pull-out tool to remove valve seat. Check parts, and replace if worn.
- 5) Check O-rings (40/44E) and support rings (41/44F) and replace as necessary.

SEAL AND PLUNGER REPLACEMENT

- 1) Unscrew the 8 x nut (47), remove valve casing by pulling it out to the front. Remove seal sleeve (35). Remove tension spring (38A) and seal parts (36-38) from seal sleeve. Check plunger surface and seals (37). Replace worn parts.
- 2) After removing clipping (32) and support ring (33), check leakage seal (33A) and replace if necessary.
- 3) If the surface of the plunger is worn, screw out the plunger (29) with a size 13 tool. Clean centring and front surface of crosshead with plunger (25).
- 4) Thread new plunger carefully through oiled seals in seal sleeve. Coat thread of new plunger lightly with suitable bonding agent (locktite).
- 5) Then insert seal sleeve with plunger into crankcase guide. Crank drive until plunger with crosshead (25) pushes against plunger (29). Tighten plunger (29) to 22 ft. lbs. using a size 13 torque wrench.

NOTE: The leakage seal (39) has to be installed so that its cut-outs cover the 3 mm dia. bores of the seal sleeves (35) as well as the 3 mm dia. drip-return bores of the valve casing.

DISASSEMBLY OF CRANKCASE

- 1) Remove valve casing (#43) and plunger pipe (#28B), drain oil.
- 2) Screw off gear cover (#4) and bearing cover (#14).
- 3) Remove connecting rod screws (#24) and push the front of connecting rod forward as far as possible. Remove back halves of connecting rods, note which position from which they came from.
- 4) Turning the crankshaft slightly, carefully hit on side of crankshaft (#22) with a rubber mallet until crankshaft is loose.
- 5) Check crankshaft and bearing for damage, replace if needed.

REASSEMBLY

- 6) Using a soft tool, press in the outer bearing ring until the outer edge lines up with the outer edge of crankcase (#1). Attach bearing cover (#14) with shaft seal and o-ring (#16) in place. Fit crankshaft through bearing hole on the opposite side. Press in bearing with bearing cover, keeping the shaft in a horizontal position and turning it slowly so that taper rollers touch the edge of outer bearing ring.
- 7) Adjust axial bearing clearance to at least .004" and maximum at .006 by placing fitting discs (#20A & 20B) under the bearing cover.
- 8) After assembly the shaft should turn easily with very little clearance.
- 9) Bolt connecting rod halves together making sure they are replaced in the same position from which they came from. Tighten connecting rod screws to 264 in.-lbs.

Model LP700 Dimensions (inches)

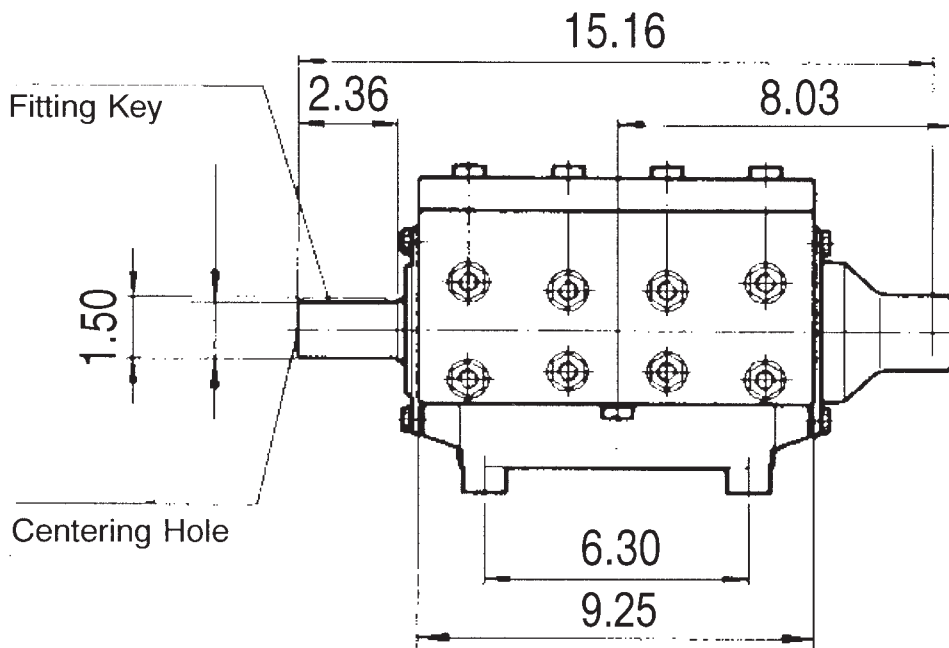
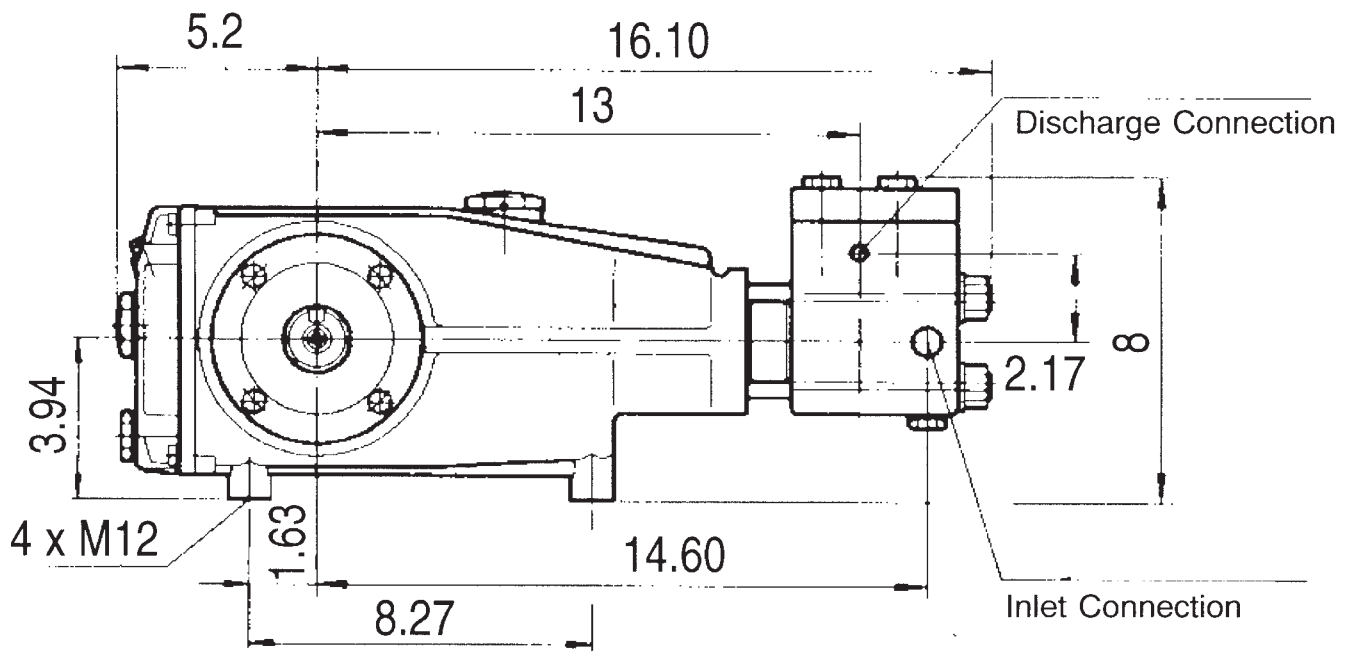

GIANT INDUSTRIES LIMITED WARRANTY

Giant Industries, Inc. pumps and accessories are warranted by the manufacturer to be free from defects in workmanship and material as follows:

1. For portable pressure washers and car wash applications, the discharge manifolds will never fail, period. If they ever fail, we will replace them free of charge. Our other pump parts, used in portable pressure washers and in car wash applications, are warranted for five years from the date of shipment for all pumps used in NON-SALINE, clean water applications.

2. One (1) year from the date of shipment for all other Giant industrial and consumer pumps.
3. Six (6) months from the date of shipment for all rebuilt pumps.
4. Ninety (90) days from the date of shipment for all Giant accessories.

This warranty is limited to repair or replacement of pumps and accessories of which the manufacturer's evaluation shows were defective at the time of shipment by the manufacturer. The following items are NOT covered or will void the warranty:

1. Defects caused by negligence or fault of the buyer or third party.
2. Normal wear and tear to standard wear parts.
3. Use of repair parts other than those manufactured or authorized by Giant.
4. Improper use of the product as a component part.
5. Changes or modifications made by the customer or third party.
6. The operation of pumps and or accessories exceeding the specifications set forth in the Operations Manuals provided by Giant Industries, Inc.

Liability under this warranty is on all non-wear parts and limited to the replacement or repair of those products returned freight prepaid to Giant Industries which are deemed to be defective due to workmanship or failure of material. A Returned Goods Authorization (R.G.A.) number and completed warranty evaluation form is required prior to the return to Giant Industries of all products under warranty consideration. Call (419)-531-4600 or fax (419)-531-6836 to obtain an R.G.A. number.

Repair or replacement of defective products as provided is the sole and exclusive remedy provided hereunder and the MANUFACTURER SHALL NOT BE LIABLE FOR FURTHER LOSS, DAMAGES, OR EXPENSES, INCLUDING INCIDENTAL AND CONSEQUENTIAL DAMAGES DIRECTLY OR INDIRECTLY ARISING FROM THE SALE OR USE OF THIS PRODUCT.

THE LIMITED WARRANTY SET FORTH HEREIN IS IN LIEU OF ALL OTHER WARRANTIES OR REPRESENTATION, EXPRESS OR IMPLIED, INCLUDING WITHOUT LIMITATION ANY WARRANTIES OR MERCHANTABILITY OR FITNESS FOR A PARTICULAR PURPOSE AND ALL SUCH WARRANTIES ARE HEREBY DISCLAIMED AND EXCLUDED BY THE MANUFACTURER.



GIANT INDUSTRIES, INC., 900 N. Westwood Ave., P.O. Box 3187, Toledo, Ohio 43607
PHONE (419) 531-4600 FAX (419) 531-6836 www.giantpumps.com
© Copyright 1998 Giant Industries, Inc.

12/98 LP700.pm6