

Models HR2020/HR2527A HR3025/HR3030 Pumps

Consumer Pumps

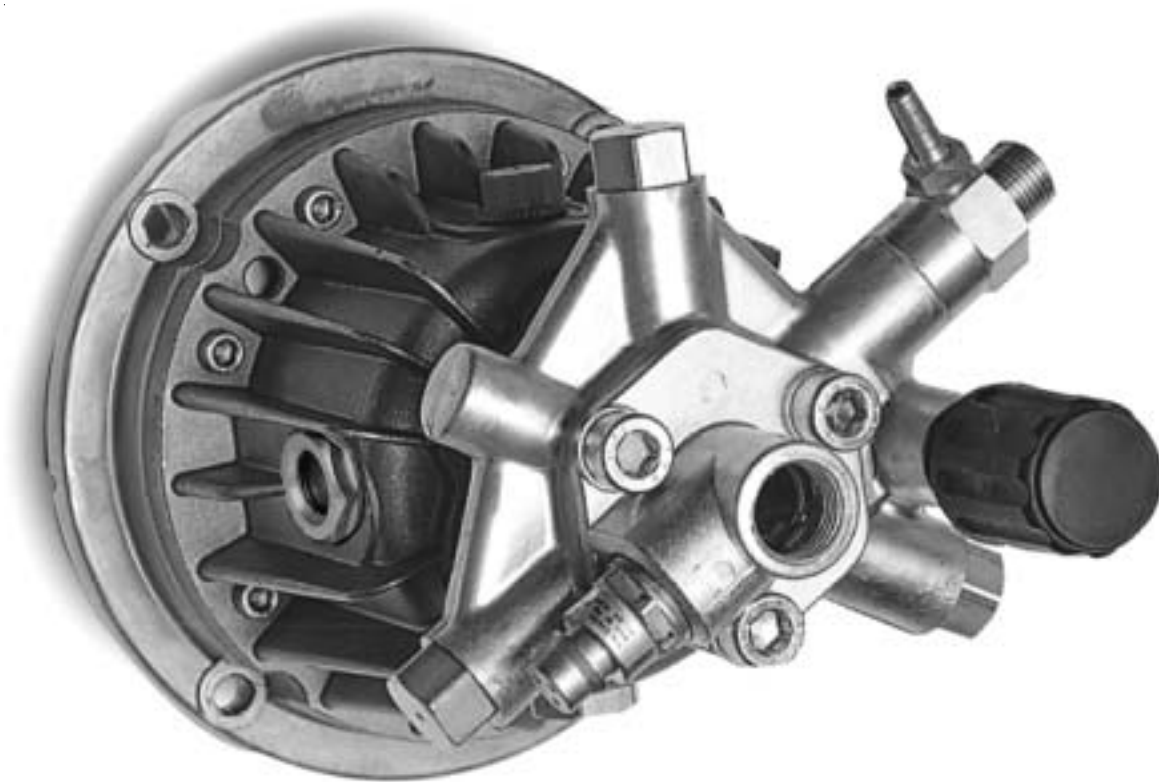

HR2527A shown

GIANT

MADE IN THE USA



Updated 10/09

Contents:

Installation Instructions:	page 2
Pump Specifications:	pages 3-5
Exploded View:	page 6
Parts List:	page 7
Kits/Torque Specs:	page 8
Trouble Shooting Chart:	page 9
Recommended Spare Parts List:	page 9
Repair Instructions:	pages 10-11
Dimensions/Warranty:	back page

INSTALLATION INSTRUCTIONS

Installation of the Giant Industries, Inc., pump is not a complicated procedure, but there are some basic steps common to all pumps. The following information is to be considered as a general outline for installation. If you have unique requirements, please contact Giant Industries, Inc. or your local distributor for assistance.

1. The pump should be installed flat on a base to a maximum of a 15 degree angle of inclination to ensure optimum lubrication.
2. The inlet to the pump should be sized for the flow rate of the pump with no unnecessary restrictions that can cause cavitation. Teflon tape should be used to seal all joints. Maximum inlet fluid temperature is 80°F.
3. The discharge plumbing from the pump should be properly sized to the flow rate to prevent line pressure loss to the work area. It is essential to provide a safety bypass valve between the pump and the work area to protect the pump from pressure spikes in the event of a blockage or the use of a shut-off gun.

4. Use of a dampener is necessary to minimize pulsation at drive elements, plumbing, connections, and other system areas. The use of a dampener with Giant Industries, Inc. pumps is optional, although recommended by Giant Industries, Inc. to further reduce system pulsation. Dampeners can also reduce the severity of pressure spikes that occur in systems using a shut-off gun. A dampener must be positioned downstream from the unloader.

6. Before beginning operation of your pumping system, remember: Check that the crankcase and seal areas have been properly lubricated per recommended schedules. Do not run the pump dry for extended periods of time. Cavitation will result in severe damage. Always remember to check that all plumbing valves are open and that pumped media can flow freely to the inlet of the pump.

Finally, remember that high pressure operation in a pump system has many advantages. But, if it is used carelessly and without regard to its potential hazard, it can cause serious injury.

IMPORTANT OPERATING CONDITIONS

Failure to comply with any of these conditions invalidates the warranty.

1. Prior to initial operation, Check for proper oil level. DO NOT OVERFILL.

**Use Giant Oil - P/N 01153
(20W-50 Synthetic)**

Crankcase oil should be changed after the first 50 hours of operation, then at regular intervals of 200 hours or less depending on operating conditions.

Since it is difficult to determine the oil level in the pump, check for signs of oil leakage around the pump before and during operation. The best areas to check are between the manifold and the crankcase and between the adapting plate and the engine / motor mounting surface. Lastly, you can see if there is any leakage around the vent cap (on the top of the pump).

If everything looks okay, continue to use the pump. At least once per year (or every 200 hours), remove the oil from the pump and replace with the required amount of oil. (See page 3)

2. Pump operation must not exceed rated pressure, volume, or RPM. A pressure relief device must be installed in the discharge of the system.
3. Acids, alkalines, or abrasive fluids cannot be pumped unless approval in writing is obtained before operation from Giant Industries, Inc.
4. Run the pump dry approximately 10 seconds to drain the water before exposure to freezing temperatures.

NOTE: Contact Giant Industries for Service School Information. Phone: (419)-531-4600

Specifications Model HR2020 Axial Pump

Volume HR2020A	1.8 GPM
Maximum Discharge Pressure	2000 PSI
Maximum Inlet Pressure	Up to 90 PSIG ¹
RPM	3450
Plunger Diameter	16mm
Stroke	3.5mm (4.8 ° angle)
Crankcase Oil Capacity	4.5 fl. oz.
Temperature of Pumped Fluids	Up to 80 °F
Inlet Port	1 x 1/2" NPT
Discharge Ports	3/8" NPT
Shaft Rotation	Clockwise
Weight	11.7 lbs. (12.7 lbs.)
Width	6-9/16"
Height	7-25/32"
Swash Plate Bore	3/4" x 3/16" Keyway*
Valve Type	Polyamide Plastic

¹ **A 25 PSIG minimum inlet pressure is required.**

*** For 5/8" bore, add 09134 kit.**

HR3030 ELECTRIC HORSEPOWER REQUIREMENTS					
RPM	GPM	1500 PSI	2000 PSI	2500 PSI	3000 PSI
3450	1.8	1.8	2.5	3.1	3.7

HR2020 GAS HORSEPOWER REQUIREMENTS					
RPM	GPM	250 PSI	500 PSI	1500 PSI	2000 PSI
3450	1.8	0.4	0.8	2.5	3.3

HORSEPOWER RATINGS:

The rating shown are the power requirements for the pump. Gas engine power outputs must be approximately twice the pump power requirements shown above.

We recommend a 1.15 service factor be specified when selecting an electric motor as the power source. To compute specific pump horsepower requirements, use the Following formula:

$$\text{Electric HP} = (\text{GPM} \times \text{PSI}) / 1450$$

$$\text{Gas HP} = (\text{GPM} \times \text{PSI}) / 1100$$

Specifications Model HR2527A Axial Pump

Volume HR2527A	2.5 GPM
Maximum Discharge Pressure	2750 PSI
Maximum Inlet Pressure	Up to 90 PSIG ¹
RPM	3450
Plunger Diameter	16mm
Stroke	5.3mm (7.1 ° angle)
Crankcase Oil Capacity	4.5 fl. oz.
Temperature of Pumped Fluids	Up to 80 °F
Inlet Port	1 x 1/2" NPT
Discharge Ports	3/8" NPT
Shaft Rotation	Clockwise
Weight	11.7 lbs. (12.7 lbs.)
Width	6-9/16"
Height	7-25/32"
Swash Plate Bore	3/4" x 3/16" Keyway
Valve Type	Polyamide Plastic

¹ A 25 PSIG minimum inlet pressure is required.

HR2527A ELECTRIC HORSEPOWER REQUIREMENTS					
RPM	GPM	1000 PSI	1500 PSI	2000 PSI	2750 PSI
3450	2.5	1.7	2.6	3.4	4.7

HR2527A GAS HORSEPOWER REQUIREMENTS					
RPM	GPM	1000 PSI	1500 PSI	2000 PSI	2750 PSI
3450	2.5	2.3	3.4	4.5	6.3

HORSEPOWER RATINGS:

The rating shown are the power requirements for the pump. Gas engine power outputs must be approximately twice the pump power requirements shown above.

We recommend a 1.15 service factor be specified when selecting an electric motor as the power source. To compute specific pump horsepower requirements, use the Following formula:

$$\text{Electric HP} = (\text{GPM} \times \text{PSI}) / 1450$$

$$\text{Gas HP} = (\text{GPM} \times \text{PSI}) / 1100$$

Specifications

Model HR3025/HR3030

Axial Pump

Volume	3.0 GPM
Maximum Discharge Pressure (HR3025)	2500 PSI
Maximum Discharge Pressure (HR3030)	3000 PSI
Maximum Inlet Pressure	Up to 90 PSIG ¹
RPM	3450
Plunger Diameter	16mm
Stroke	5.9mm (8.0 ° angle)
Crankcase Oil Capacity	4.5 fl. oz.
Temperature of Pumped Fluids	Up to 80 °F
Inlet Port	1 x 1/2" NPT
Discharge Ports	3/8" NPT
Shaft Rotation	Clockwise
Weight	11.4 lbs.
Width	6-7/16"
Height	10-1/4"
Swash Plate Bore (HR3025)	3/4"x3/16" Keyway
Swash Plate Bore (HR3030)	1"x3/16" Keyway
Valve Type	Polyamide Plastic

¹ A 25 PSIG minimum inlet pressure is required.

HR3025 ELECTRIC HORSEPOWER REQUIREMENTS					
RPM	GPM	1000 PSI	1500 PSI	2000 PSI	2500 PSI
3450	3.0	2.1	3.1	4.1	5.1

HR3025 GAS HORSEPOWER REQUIREMENTS					
RPM	GPM	1000 PSI	1500 PSI	2000 PSI	2500 PSI
3450	3.0	2.7	4.1	5.5	6.8

HR3030 ELECTRIC HORSEPOWER REQUIREMENTS					
RPM	GPM	1500 PSI	2000 PSI	2500 PSI	3000 PSI
3450	3.0	3.1	4.1	5.1	6.2

HR3030 GAS HORSEPOWER REQUIREMENTS					
RPM	GPM	1500 PSI	2000 PSI	2500 PSI	3000 PSI
3450	3.0	4.1	5.5	6.8	8.2

HORSEPOWER RATINGS:

The rating shown are the power requirements for the pump. Gas engine power outputs must be approximately twice the pump power requirements shown above.

We recommend a 1.15 service factor be specified when selecting an electric motor as the power source. To compute specific pump horsepower requirements, use the Following formula:

$$\text{Electric HP} = (\text{GPM} \times \text{PSI}) / 1450$$

$$\text{Gas HP} = (\text{GPM} \times \text{PSI}) / 1100$$

HR2020/HR2527A/HR3025/HR3030 EXPLODED VIEW

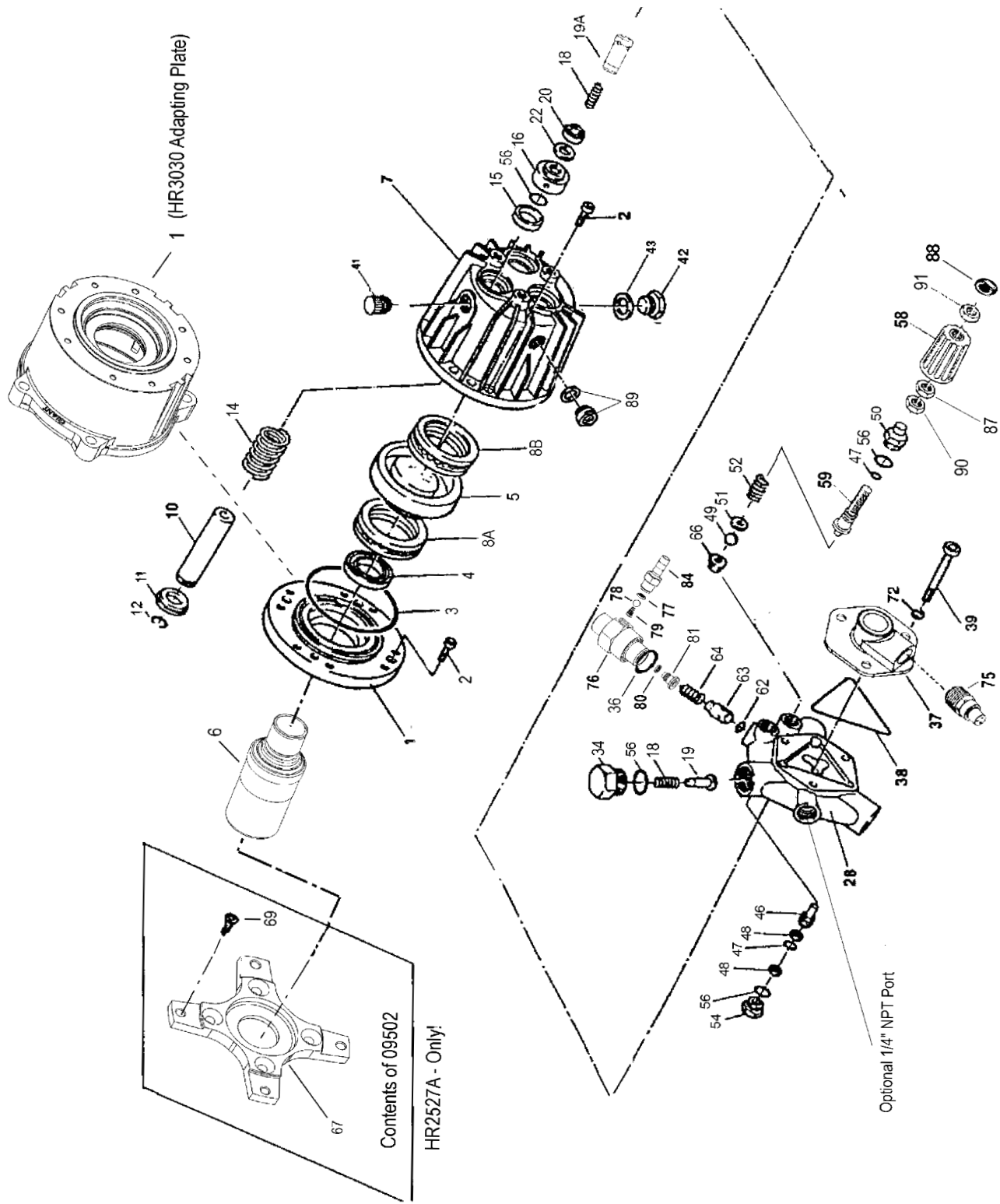

HR2020/HR2527A/HR3025/HR3030 PARTS LIST

ITEM PART #	DESCRIPTION	QTY.	ITEM PART #	DESCRIPTION	QTY.
1*	07874 Adapting Plate (HR2020)	1	43 08192	Gasket	1
1*	06311 Adapting Plate (HR2527A/HR3025)	1	46 06423	Piston	1
1*	06403 Adapting Plate (HR3030)	1	47 07937	O-Ring	2
2	07881A Socket Head Cap Screw ¼"	8	48 12031-0002	Back-Up Ring	2
3	07344 O-Ring	1	49 06227	Ball, By Pass Valve	1
4	07805 Radial Shaft Seal	1	50 06324	Adjusting Plug	1
5**	07947 4.8° Wobble Plate (HR2020)	1	51 07917A	Washer	1
5**	06419 7.1° Piece Wobble Plate (HR2527A)	1	52 06608	Adjusting Spring	1
5**	06402 8° Wobble Plate (HR3025/HR3030)	1	54 06239	Guide Plug	1
6	06393 Steel Shaft ¾" (HR2527A/HR3025)	1	56 12007	O-Ring	8
6	06401 Steel Shaft 1" (HR3030)	1	58 07045	Handwheel	1
7	08089 Crankcase	1	59 06524	Adjusting Screw	1
8A*	06264 Rear Bearing , Complete (HR2020 only)	1	62 12326	O-Ring	1
8A*	06300 Rear Bearing, Complete (except HR2020)	1	63 12325	Kick-Back Valve Cone	1
8B**	07930A Front Bearing, Complete (HR2020 only)	1	64 12328	Kick-Back Valve Spring	1
8B**	06301 Front Bearing, Complete (except HR2020)	1	66 07935A	By Pass Valve Seat	1
10	06319 Plunger	3	67+ 06414	Mounting Flange "X" Style (HR2527)	1
11	06318 Spring Disc Retainer	3	69+ 07467	Bolt (HR2527)	4
12	06291 Clip Ring	3	72 06224	Washer	3
14	07873 Plunger Spring	3	75 23422A	Thermal Valve	1
15	06316 Oil Seal	3	76 06303	Injector Retainer	1
16	06317 Spacer Ring	3	77 12516-001	O-Ring Viton	1
18	07374 Valve Spring	6	78 23010-0100	Ball, 7/32" Dia. ss	1
19	06295 Valve Cone (Discharge)	3	79 23009	Spring, Injector	1
19A	06267 Valve Cone (Inlet)	3	80 06312	O-Ring	1
20	06315 V-Sleeve	3	81 ^A 06308 ^A	Orifice, 1.8mm	1
22	06290 Pressure Ring	3	81 ^A 06339 ^A	Orifice, 2.1mm	1
28	06424 ⁺⁺ Manifold	1	81 ^A 06340 ^A	Orifice, 2.3mm	1
34	07379 Manifold Plug	3	84 12517	Hose Barb	1
36	07913 O-Ring	1	87 07044	Locknut	3
37	06313 Suction Flange	1	88 07046	Cover	1
38	07910A O-Ring, Flange	1	89 08250	Sightglass w/gasket	1
39	06320 Stud Bolt	3	90 07939	Nut	1
41	08083 Oil Fill Cap	1	91 07068	Locknut w/Nylon Insert	1
42	06273 Oil Drain Plug	1			

+ 09502 Gasoline Flange Kit

^A= See pump numbering system on page 8

* When ordering a 07847, please order 17001, which includes 7847, 07344, 07805, 06264 - HR2020

* When ordering a 06311, please order 17021 which includes 06311, 07344, 07805, 06300 - HR2527A/HR3025

* When ordering a 06403, please order 17038 which includes 06403, 07344, 07805, 06300 - HR3030

** When ordering a 07947 please order 17009, which includes 07947 and 07930A - HR2020

** When ordering a 06419, please order 17036, which includes 06419, 06393, & 06301 - HR2527A

** When ordering a 06402, please order 17051, which includes 06402, 06393 & 06301 - HR3025

** Available w/ 1/4" NPT gauge port (06424P)

HR2020/HR2527A/HR3025/HR3030 Repair Kits

**Plunger Packing Kit
09465**

<u>Item</u>	<u>Part #</u>	<u>Description</u>	<u>Qty.</u>
22	06290	Pressure Ring	3
20	06315	V-Sleeve	3

**Unloader Repair Kit
09235**

<u>Item</u>	<u>Part #</u>	<u>Description</u>	<u>Qty.</u>
36	07913	O-Ring	1
47	07937	O-Ring, Adjusting Screw	2
48	12031-0002	Teflon Back-Up Ring	2
49	06227	8mm Ball	1
56	12007	O-Ring	2
62	12326	O-Ring	1
66	07935A	By Pass Seat	1

**Valve Assembly Kit
09466**

<u>Item</u>	<u>Part #</u>	<u>Description</u>	<u>Qty.</u>
18	07374	Valve Spring	6
19A	06267	Guided P-Valve	3
19	06295	Discharge Valve Cone	3

**Oil Seal Kit
09468**

<u>Item</u>	<u>Part #</u>	<u>Description</u>	<u>Qty.</u>
15	06316	Plunger Oil Seal	3

**HR2020/HR2527A/HR3025/HR3030 SERIES
TORQUE SPECIFICATIONS**

<u>Position</u>	<u>Item#</u>	<u>Description</u>	<u>Torque Amount (ft.-lbs)</u>
2	07881A	Socket Head Cap Screw 1/4"	100 in-lbs.
39	06320	Stud Bolt	360 in-lbs.

GX and HR Pump Part Numbering System

GX or HR Series	Flow	Pressure (in 100 psi increments)		Injector Size	Thermal Relief Valve	Wobble Plate Shaft Bore
Vertical	20=GPM	25=2500 PSI		1=2.1 mm	1=1/2"	2=7/8"
Horizontal	23=GPM			2=1.8mm		1=3/4"
	25=GPM			3=2.3mm		3=1"
						4=5/8"
GX or HR	2.5	25	-	1	1	1

For example, a GXV2525-112 is a GX pump that produces 2.5 GPM @ 2500 PSI, has a injector with a 2.1mm Orifice, 1/2" thermal relief valve and 7/8" wobble plate bore.

PUMP SYSTEM MALFUNCTION

MALFUNCTION	CAUSE	REMEDY
The Pressure and/ or the Delivery Drops	Worn packing seals Broken valve spring Belt slippage Worn or Damaged nozzle Fouled discharge valve Fouled inlet strainer Worn or Damaged hose Worn or Plugged relief valve on pump Cavitation Unloader	Replace packing seals Replace spring Tighten or Replace belt Replace nozzle Clean valve assembly Clean strainer Repair/Replace hose Clean, Reset, and Replace worn parts Check suction lines on inlet of pump for restrictions Check for proper operation
Water in crankcase	High humidity Worn seals	Reduce oil change interval Replace seals
Noisy Operation	Worn bearings Cavitation	Replace bearings, Refill crankcase oil with recommended lubricant Check inlet lines for restrictions and/or proper sizing
Rough/Pulsating Operation with Pressure Drop	Worn packing Inlet restriction Accumulator pressure Unloader Cavitation	Replace packing Check system for stoppage, air leaks, correctly sized inlet plumbing to pump Recharge/Replace accumulator Check for proper operation Check inlet lines for restrictions and/or proper size
Pump Pressure Drop at gun Rated, Pressure	Restricted discharge plumbing	Re-size discharge plumbing to flow rate of pump
Excessive Leakage	Worn plungers Worn packing/seals Excessive vacuum Cracked plungers Inlet pressure too high	Replace plungers Adjust or Replace packing seals Reduce suction vacuum Replace plungers Reduce inlet pressure
High Crankcase Temperature	Wrong Grade of oil Improper amount of oil in crankcase	Giant oil is recommended Adjust oil level to proper amount

Preventative Maintenance Check-List & Recommended Spare Parts List					
Check	Daily	Weekly	50hrs	Every 500 hrs	Every 1500 hrs
Oil Level/Quality	X				
Oil Leaks	X				
Water Leaks	X				
Belts, Pulley		X			
Plumbing		X			
Recommended Spare Parts					
Oil Change (1 Quart) p/n 1153			X	X	
Plunger Packing Kit (1 kit/pump) (See page 8 for kit list)					X
Oil Seal Kit (1 kit/pump) (See page 8 for kit list)					X
Valve Spare Parts (1 kit/pump) (See page 8 for kit list)					X
Unloader Repair Kit (1 kit/pump)					X

REPAIR INSTRUCTIONS - HR2020/HR2527A/HR3025/HR3030

NOTE: Always take time to lubricate all metal and nonmetal parts with a light film of oil before reassembly. This step will ensure proper fit, at the same time protecting the pump's nonmetal parts (elastomers) from cutting and scoring.

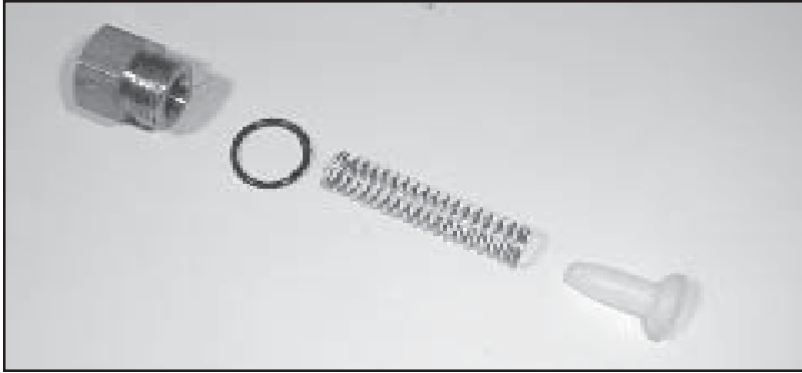

1. With a 19mm socket wrench, remove the three discharge valve plugs (34). Inspect the valve plug o-rings (56) for wear, and replace as necessary. Remove the valve spring (18) and valve cone (19) from the manifold (28). Inspect the parts for wear and replace as necessary.

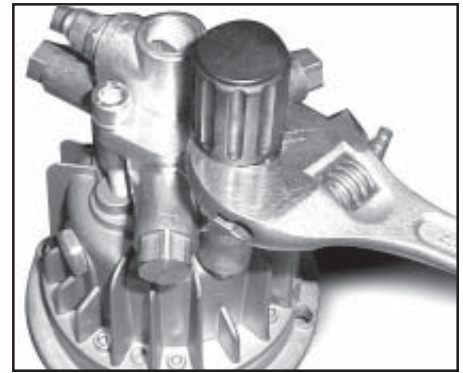

2. With a 19mm crescent wrench, remove the adjusting screw assembly (50, 56, 47, and 59). Unscrew the adjusting screw (59) from the adjusting screw plug (50).

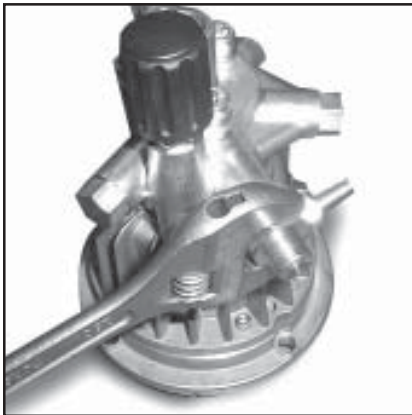

3. With a crescent wrench, remove the injector retainer (76).

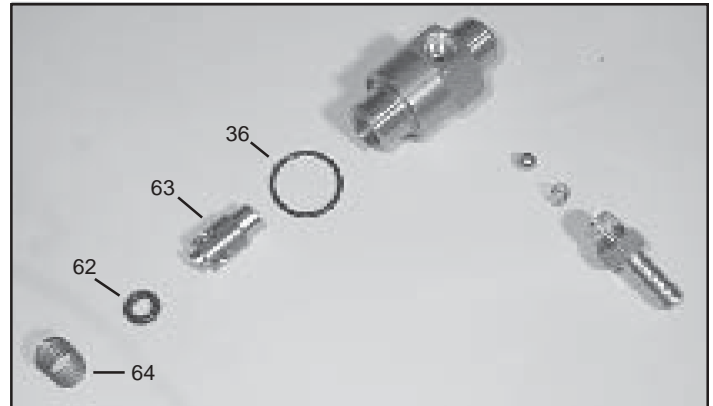

4. Inspect the o-ring (36) for wear and replace as necessary. Remove the kickback valve spring (64), kickback valve cone (63), and the o-ring (62) from the manifold (28). Inspect and clean the siphon injector and ball clean parts for wear and replace as necessary.

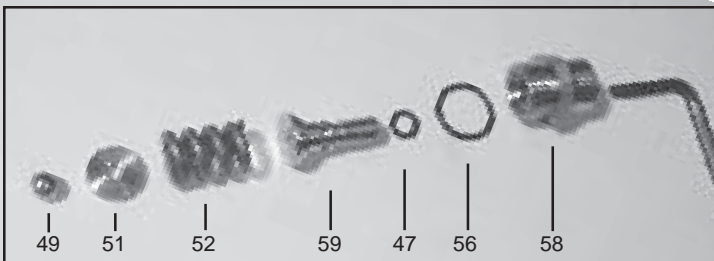

5. Inspect the o-rings (56 and 47) for wear and replace as necessary. Remove the adjusting spring (52), washer (51) and by pass valve ball (49) from the manifold (28). Inspect the parts for wear and replace

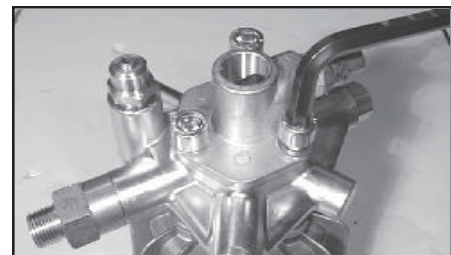

6. Next, remove the three manifold stud nuts (39) with a 17mm wrench. Remove the suction flange (37) and flange o-ring (38). Inspect the o-ring for wear and replace as necessary.

REPAIR INSTRUCTIONS - HR2020/HR2527A/HR3025/HR3030

NOTE: Always take time to lubricate all metal and nonmetal parts with a light film of oil before reassembly. This step will ensure proper fit, at the same time protecting the pump's nonmetal parts (elastomers) from cutting and scoring.

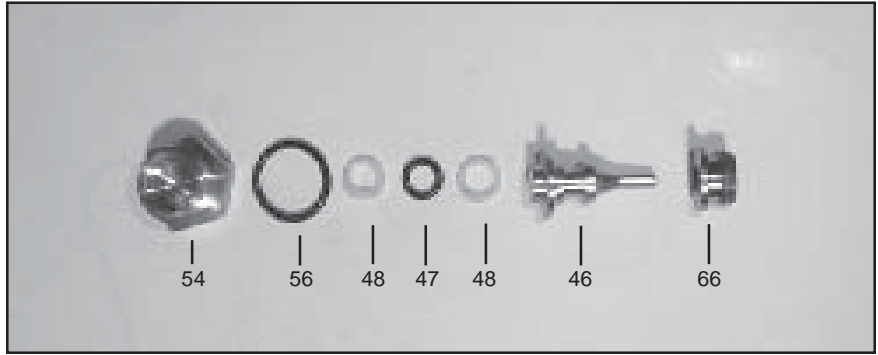
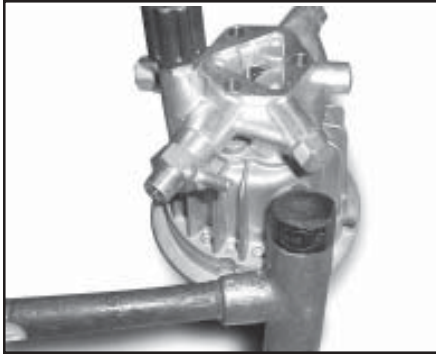

7. Tap the back of the manifold (28) with a rubber mallet to dislodge, and slide off the plungers (10). Take note of the position of the discharge port so as to place the port in the same position during reassembly.

8. With a 19mm socket wrench, remove the guide plug (54) and o-ring (56) from the manifold (28). Remove the piston (46), o-ring (47), and backup rings (48). Using a 7/32" Allen wrench, remove the bypass valve seat (66). Inspect the parts for wear and replace as necessary.

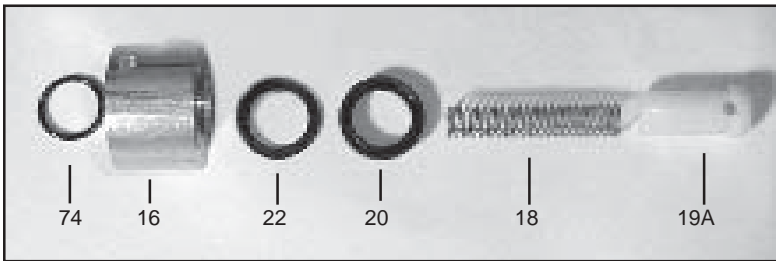

9. Remove the valve cones (19A), valve springs (18), v-sleeves (20) and pressure rings (22). Inspect for wear and replace as necessary. Remove the spacer ring (16) and flinger (56) from the plungers (10).

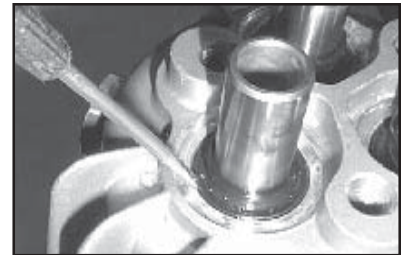

10. If the crankcase oil seals (15) are to be replaced, they can be removed by prying loose with a small screwdriver. Take care not to make contact with the plunger (10) and pry out the oil seals from their housing.

11. Reassemble in reverse order. Fill the crankcase until the proper amount of oil (see specifications page 3). The pump is now ready for operation.

HR2020/HR2527A/HR3025/HR3030 SERIES DIMENSIONS

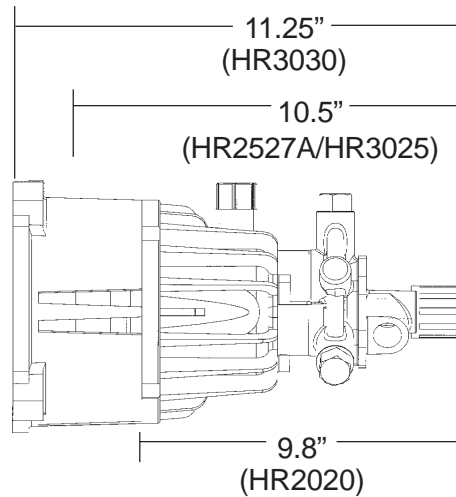
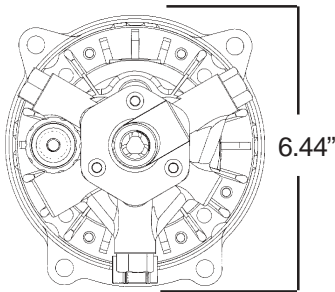

GIANT INDUSTRIES LIMITED WARRANTY

Giant Industries, Inc. pumps and accessories are warranted by the manufacturer to be free from defects in workmanship and material as follows:

1. For portable pressure washers and self-service car wash applications, the discharge manifolds are guaranteed for the life of the pump. Our other pump parts, used in portable pressure washers and in car wash applications, are warranted for five years from the date of shipment for all pumps used in NON-SALINE, clean water applications.
2. One (1) year from the date of shipment for all other Giant industrial and consumer pumps.
3. Six (6) months from the date of shipment for all rebuilt pumps.
4. Ninety (90) days from the date of shipment for all Giant accessories.

This warranty is limited to repair or replacement of pumps and accessories of which the manufacturer's evaluation shows were defective at the time of shipment by the manufacturer. The following items are NOT covered or will void the warranty:

1. Defects caused by negligence or fault of the buyer or third party.
2. Normal wear and tear to standard wear parts.
3. Use of repair parts other than those manufactured or authorized by Giant.
4. Improper use of the product as a component part.
5. Changes or modifications made by the customer or third party.
6. The operation of pumps and or accessories exceeding the specifications set forth in the Operations Manuals provided by Giant Industries, Inc.

Liability under this warranty is on all non-wear parts and limited to the replacement or repair of those products returned freight prepaid to Giant Industries which are deemed to be defective due to workmanship or failure of material. A Returned Goods Authorization (R.G.A.) number and completed warranty evaluation form is required prior to the return to Giant Industries of all products under warranty consideration. Call (419)-531-4600 or fax (419)-531-6836 to obtain an R.G.A. number. A complete copy of our current RGA policy may be obtained from Giant Industries by written request.

Repair or replacement of defective products as provided is the sole and exclusive remedy provided hereunder and the MANUFACTURER SHALL NOT BE LIABLE FOR FURTHER LOSS, DAMAGES, OR EXPENSES, INCLUDING INCIDENTAL AND CONSEQUENTIAL DAMAGES DIRECTLY OR INDIRECTLY ARISING FROM THE SALE OR USE OF THIS PRODUCT.

THE LIMITED WARRANTY SET FORTH HEREIN IS IN LIEU OF ALL OTHER WARRANTIES OR REPRESENTATION, EXPRESS OR IMPLIED, INCLUDING WITHOUT LIMITATION ANY WARRANTIES OR MERCHANTABILITY OR FITNESS FOR A PARTICULAR PURPOSE AND ALL SUCH WARRANTIES ARE HEREBY DISCLAIMED AND EXCLUDED BY THE MANUFACTURER.



GIANT INDUSTRIES, INC., 900 N. Westwood Ave., P.O. Box 3187, Toledo, Ohio 43607
PHONE (419) 531-4600 FAX (419) 531-6836, www.giantpumps.com
© Copyright 2009 Giant Industries, Inc.