

# Model GP7122

---

Triplex Ceramic  
Plunger Pump  
Operating Instructions/  
Repair and Service  
Manual

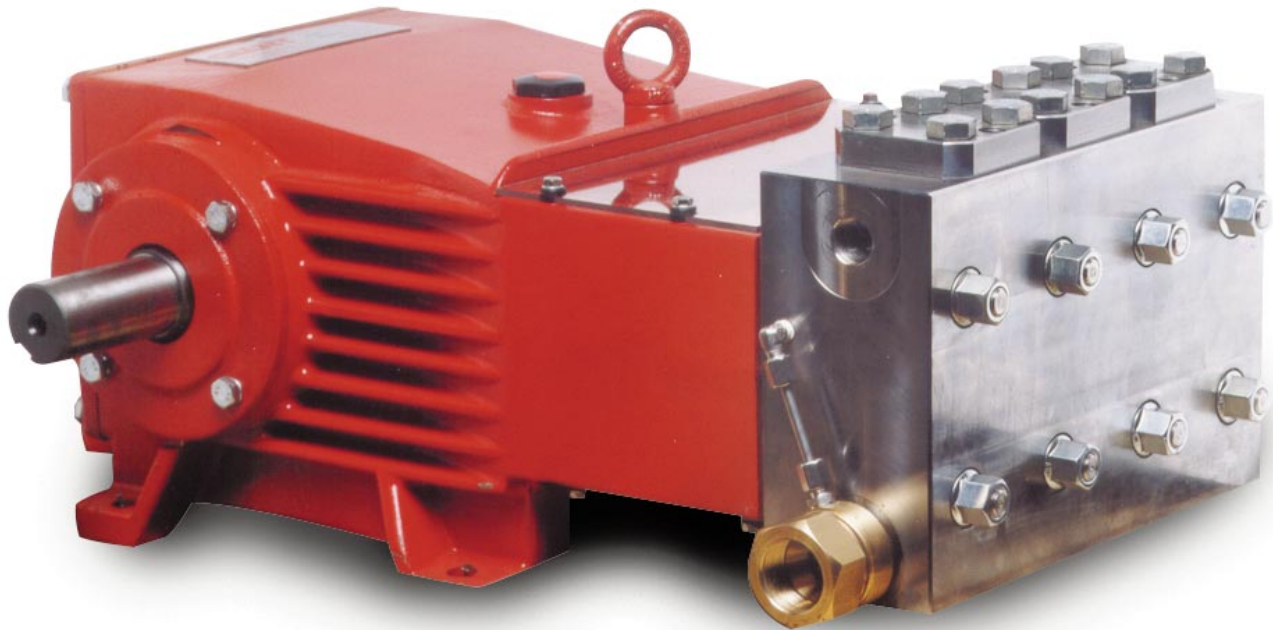

---

**GIANT**

**Contents:**

Installation Instructions:	page 2
Pump Specifications:	page 3
Exploded View:	page 4
Parts List:	page 5
Kits:	page 6
Torque Specifications:	page 6
Repair Instructions:	pages 7-10
Dimensions:	page 11
Warranty Information:	back page

---

## INSTALLATION INSTRUCTIONS

---

Installation of the Giant Industries, Inc., pump is not a complicated procedure, but there are some basic steps common to all pumps. The following information is to be considered as a general outline for installation. If you have unique requirements, please contact Giant Industries, Inc. or your local distributor for assistance.

1. The pump should be installed flat on a base to a maximum of a 15 degree angle of inclination to ensure optimum lubrication.

2. The inlet to the pump should be sized for the flow rate of the pump with no unnecessary restrictions that can cause cavitation. Teflon tape should be used to seal all joints. If pumps are to be operated at temperatures in excess of 140° F, it is important to insure a positive head to the pump to prevent cavitation.

**IMPORTANT! To guarantee weep return, it is essential that the inlet line is fitted to the support screw (#62). If the inlet line is mounted to the other side of the pump, then the whole connection part (#'s 62-62B, 64, 69-71) must be fitted to the same inlet side.**

3. A tube fitting on the side of the pumphead which allows the circulation of water between the valve casing and seal sleeves to take place. The tube fitting must always be mounted on the same side as the suction line.

4. The discharge plumbing from the pump should be properly sized to the flow rate to prevent line pressure loss to the work area. It is essential to provide a safety bypass valve between the pump and the work area to protect the pump from pressure spikes in the event of a blockage or the use of a shut-off gun.

5. Use of a dampener is necessary to minimize pulsation at drive elements, plumbing, connections, and other system areas. The use of a dampener with Giant Industries, Inc. pumps is optional, although recommended by Giant Industries, Inc. to further reduce system pulsation. Dampeners can also reduce the severity of pressure spikes that occur in systems using a shut-off gun. A dampener must be positioned downstream from the unloader.

6. Crankshaft rotation on Giant Industries, Inc. pumps should be made in the direction designated by the arrows on the pump crankcase. Reverse rotation may be safely achieved by following a few guidelines available upon request from Giant Industries, Inc. Required horsepower for system operation can be obtained from the chart on page 3.

7 Before beginning operation of your pumping system, remember: Check that the crankcase and seal areas have been properly lubricated per recommended schedules. Do not run the pump dry for extended periods of time. Cavitation will result in severe damage. Always remember to check that all plumbing valves are open and that pumped media can flow freely to the inlet of the pump.

Finally, remember that high pressure operation in a pump system has many advantages. But, if it is used carelessly and without regard to its potential hazard, it can cause serious injury.

### IMPORTANT OPERATING CONDITIONS

**Failure to comply with any of these conditions invalidates the warranty**

1. Prior to initial operation, add oil to crankcase so that the oil level is between the two lines on the oil dipstick. **DO NOT OVERFILL. SAE 80 Industrial Gear oil may be used.** Crankcase oil should be changed after the first 50 hours of operation, then at regular intervals of 500 hours or less depending on operating conditions.

2. Pump operation must not exceed rated pressure, volume, or RPM. A pressure relief device must be installed in the discharge of the system.

3. Acids, alkalines, or abrasive fluids cannot be pumped unless approval in writing is obtained before operation from Giant Industries, Inc.

4. Run the pump dry approximately 10 seconds to drain the water before exposure to freezing temperatures.

# Specifications Model GP7122

Volume .....	Up to 9.9 GPM
Discharge Pressure .....	Up to 10,000 PSI
Speed .....	Up to 750 RPM
Inlet Pressure .....	Up to 90 PSI <sup>1</sup>
Plunger Diameter .....	22mm
Plunger Stroke .....	48mm
Crankshaft Diameter .....	48mm
Key Width .....	14mm
Crankshaft Mounting .....	Either side
Shaft Rotation .....	Top of pulley towards manifold
Temperature of Pumped Fluids .....	Up to 140 °F
Inlet Ports .....	(2) 1 1/4" BSP <sup>2</sup>
Discharge Ports .....	(2) 3/4" BSP <sup>3</sup>
Weight .....	374 lbs.
Crankcase Oil Capacity .....	1.6 Gal.
Fluid End Material .....	Stainless Steel
Volumetric Efficiency @ 750 RPM .....	89%
Mechanical Efficiency @ 750 RPM .....	83%

Consult the factory for special requirements that must be met if the pump is to operate beyond one or more of the limits specified above.

<sup>1</sup>Positive inlet pressures are recommended!

<sup>2</sup>To convert to FNPT threads, add 13377-0100 (Adapter) and 13376-0100 (Seal)

<sup>3</sup>To convert to FNPT threads, add 14081-0100 (Adapter) and 14082 (Seal)

**System Requirements: No Unloader or Regulator allowed. Must use a safety valve and dump gun.**

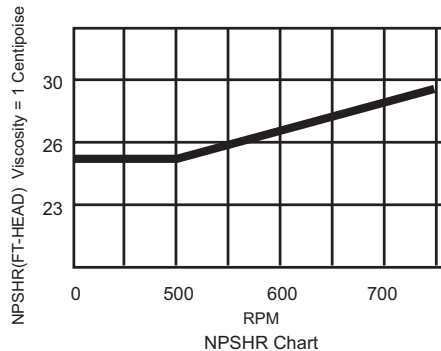
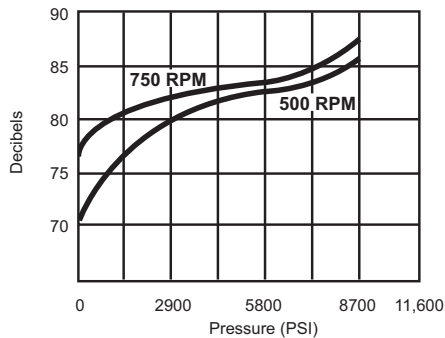

GP7122 HORSEPOWER REQUIREMENTS						
RPM	GPM	3000 PSI	5000 PSI	6000 PSI	7250 PSI	10000 PSI
300	4.0	8.6	14.3	17.1	20.7	28.6
400	5.3	11.4	18.9	22.7	27.4	37.9
550	7.3	15.6	26.1	31.3	37.8	52.1
600	7.9	16.9	28.2	33.9	40.9	56.4
650	8.6	18.4	30.7	36.9	44.5	61.4
700	9.2	19.7	32.9	39.4	47.6	65.7
750	9.9	21.2	35.4	42.4	51.3	70.7

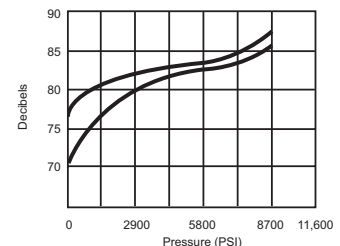

## HORSEPOWER RATINGS:

The rating shown are the power requirements for the pump. Gas engine power outputs must be approximately twice the pump power requirements shown above.

We recommend a 1.1 service factor be specified when selecting an electric motor as the power source.

To compute specific pump horsepower requirements, use the following formula:

$$\frac{\text{GPM} \times \text{PSI}}{1400} = \text{hp}$$

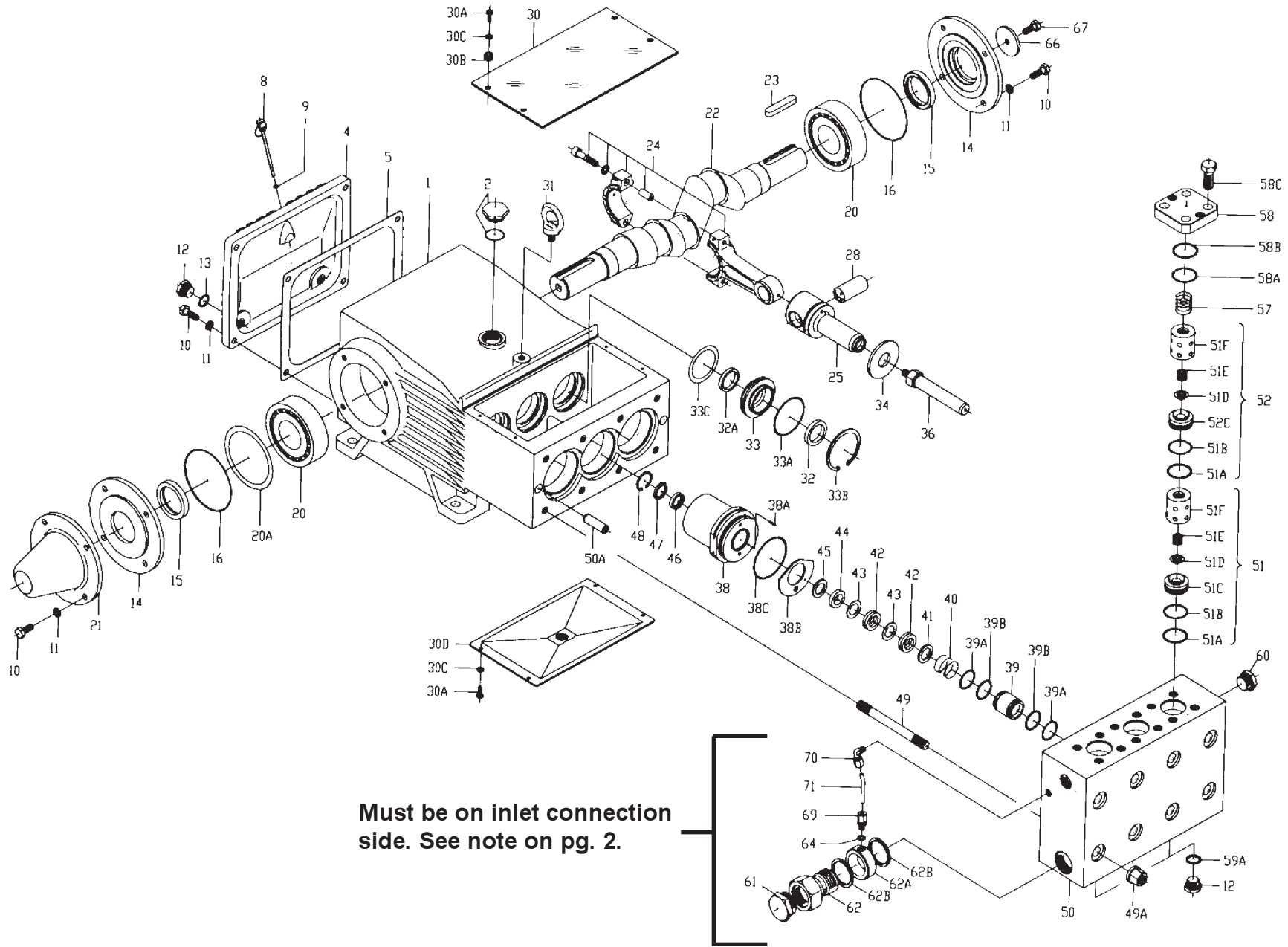

## GP7122 PARTS LIST

<u>ITEM</u>	<u>PART</u>	<u>DESCRIPTION</u>	<u>QTY.</u>	<u>ITEM</u>	<u>PART</u>	<u>DESCRIPTION</u>	<u>QTY.</u>
1	07600	Crankcase	1	39B	06266	Support Ring	6
2	13000	Oil Filler Plug Assembly	1	40	07338	Tension Spring	3
4	07601	Crankcase Cover	1	41	06753	Support Disc	3
5	07602	Seal for Crankcase Cover	1	42	06754	Spiral Ring (Packing)	6
8	07603	Oil Dip Stick	1	43	06755	Support Ring	6
9	06225	O-Ring, Dip Stick	1	44	06756	Guide Ring	3
10	13133	Hexagon Screw	12	45	06757	Pressure Ring	3
11	13134	Spring Washer	12	46	13390	Seal Ring	3
12	07606	Drain Plug	5	47	06758	Spacer Disc	3
13	07182	Gasket, Drain Plug	2	48	07690	Circlip	3
14	07607	Bearing Cover	2	49	13159	Stud Bolt	8
15	07608	Radial Shaft Seal	2	49A	13160	Hexagon Nut	8
16	07184	O-Ring for Bearing Cover	2	50	06759	Valve Casing	1
20	07610	Taper Roller Bearing	2	50A	13162	Centering Stud	2
20A	07611	Fitting Disc (Shim)	1-5	51A	12056	Support Ring	6
21	07612	Shaft Protector	1	51B	07354	O-Ring	6
22	13405	Crankshaft	1	51C	06760	Inlet Valve Seat	3
23	07614	Key	1	51D	06761	Valve Plate	6
24	13182	Connecting Rod Assy.	3	51E	06762	Valve Spring	6
25	13183	Crosshead Assy.	3	51F	06763	Spacer Pipe	6
28	13184	Crosshead Pin	3	52C	06764	Discharge Valve Seat	3
30	07619	Cover Plate	1	57	06078	Tension Spring	3
30A	07225-0100	Hexagon Screw	8	58	07699	Plug	3
30B	13136	Grommet	4	58A	07700	O-Ring	3
30C	07622	Disc	8	58B	07693	Support Ring	3
30D	13154	Cover	1	58C	07702	Hexagon Screw	12
31	07623	Eye Bolt	1	59A	07661	Copper Ring (Gasket)	3
32	07624	Radial Shaft Seal	3	60	13150	Plug 3/4" BSP	1
32A	07625	Seal Ring	3	61	13151	Plug 1-1/4" BSP	1
33	07626	Seal Retainer	3	62	06765	Connecting Screw	1
33A	07627	O-Ring for Seal Retainer	3	62A	06766	Connection Ring	1
33B	07628	Circlip for Seal Retainer	3	62B	06767	Seal Ring	2
34	13137	Oil Scraper (Flinger)	3	63	06589	Plug	1
36	06748	Plunger	3	64	07258-0100	Steel Ring	2
38	06749	Seal Sleeve	3	66	13362	Disc for Crankshaft	1
38A	22764	Serrated Pin	3	67	13358	Hexagon Screw	1
38B	06750	Leakage Gasket	3	69	06588	Screw-in Connector	1
38C	06751	O-Ring	3	70	06768	Threaded Elbow	1
39	06752	Seal Case	3	71	06769	Curved Leakage Pipe	1
39A	07150	O-Ring	6		07704	Valve Tool (not shown)	1

## GP7122 REPAIR KITS

### Plunger Packing Kit #09551

<u>Item</u>	<u>Part #</u>	<u>Description</u>	<u>Qty.</u>
39A	07150	O-Ring	6
39B	06266	Support Ring	6
42	06754	Spiral Ring (Packing)	6
43	06755	Support Ring	6
44	06756	Guide Ring	3
46	13390	Seal Ring	3

### Inlet Valve Assembly Kit #09552

<u>Item</u>	<u>Part #</u>	<u>Description</u>	<u>Qty.</u>
51A	12056	Support Ring	1
51B	07354	O-Ring	1
51C	06760	Inlet Valve Seat	3
51D	06761	Valve Plate	6
51E	06762	Valve Spring	6

### Oil Seal Kit #09225

<u>Item</u>	<u>Part #</u>	<u>Description</u>	<u>Qty.</u>
32	07624	Radial Shaft Seal	3
32A	07625	Seal Ring	3
33A	07627	O-Ring	3

### Discharge Valve Assembly Kit #09553

<u>Item</u>	<u>Part #</u>	<u>Description</u>	<u>Qty.</u>
51A	12056	Support Ring	1
51B	07354	O-Ring	1
51D	06761	Valve Plate	1
51E	06762	Valve Spring	1
52C	06764	Discharge Valve Seat	1

## GP7122 TORQUE SPECIFICATIONS

<u>Position</u>	<u>Item#</u>	<u>Description</u>	<u>Torque Amount</u>
24	13406	Inner Hexagon Screw	30 (ft.-lbs.)
36	13138	Plunger	33 (ft.-lbs.)
49A	13160	Nut	103 (ft.-lbs.)
58C	07702	Hexagon Screw	155 (ft.-lbs.)

---

## GP7122 REPAIR INSTRUCTIONS

---

**NOTE:** Always take time to lubricate all metal and non-metal parts with a light film of oil before reassembling. This step will help ensure proper fit, at the same time protecting the pump non-metal parts (elastomers) from cutting and scoring.

### TO CHECK VALVES



1) Loosen and remove screws (58C) with a 24mm socket wrench.



2) Take plugs (58) out of valve casing (50) by tightening screws (58C) against valve casing with two screws.

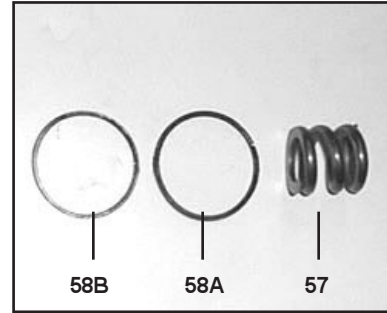

3) Remove the compression spring (57) O-Ring (58A) and support ring (58B).



4) Take out valve assemblies (52 & 51) using either tool (part #07704) or a stud bolt.

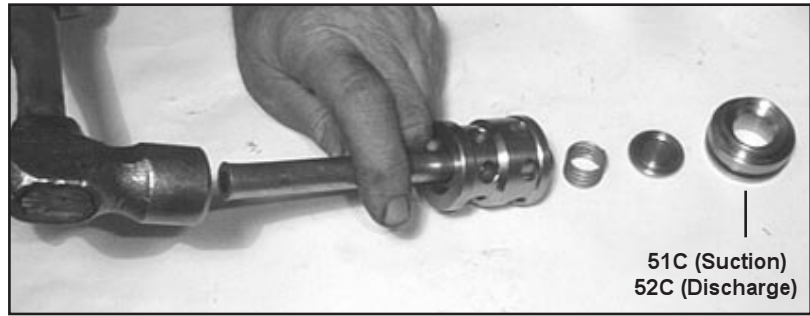

5) Valve seats (51C and 52C) are pressed out of spacer pipe (51F) by hitting the valve plate (51D) with a socket extension.

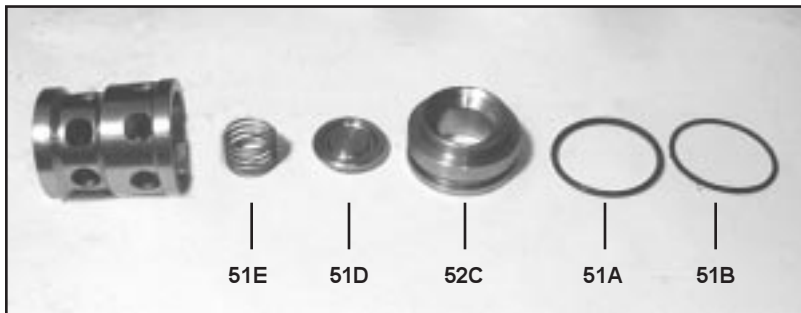

6) Check surfaces of valve plate (51D), valve seat (51C or 52C), o-rings (51A), and support rings (51B). Replace worn parts.

## GP7122 REPAIR INSTRUCTIONS

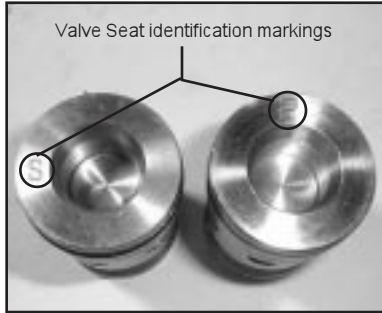

- 7) When reassembling: The inlet valve seat (51C) is 1mm smaller in diameter than the discharge valve seat (52C). Inlet valve seats are marked "S" and always have to be installed first. Discharge valve seats are marked "P" and are always to be installed on top of inlet valve. Plugs (58) are to be tensioned down evenly with screws (58C) and in crosswise pattern at 155 (ft.lbs.).

### TO CHECK SEALS

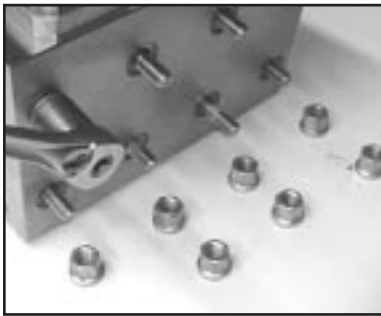

- 8) Loosen nuts (49A) with a 24mm socket wrench.

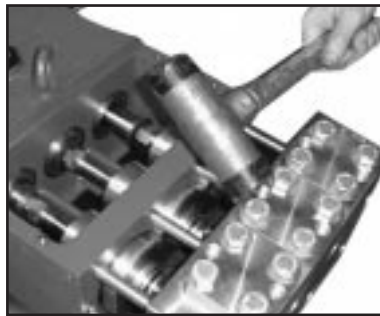

- 9) With a rubber mallet tap the back of the valve casing (50) and pull the valve casing off the stud bolt (49).

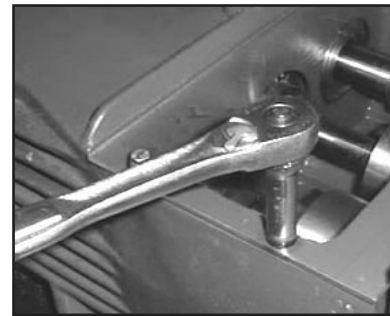

- 10) Remove cover plate (30) with a 10mm socket wrench.



- 11) By gripping hex flats, separate plunger (36) from cross-head (25) by means of two open-end wrenches (size 22mm and 27mm).



- 12) Remove tension spring (40) from seal retainer (38).



- 13) Pull seal sleeves (38) and plungers (36) out of their fittings in the crankcase (1) using ring groove as a guide.



---

## GP7122 REPAIR INSTRUCTIONS

---

**CAUTION:** Don't loosen the 3 plunger (36) before the valve casing has been removed otherwise the plunger (36) could hit against the spacer pipe (51F) when the pump is being turned.

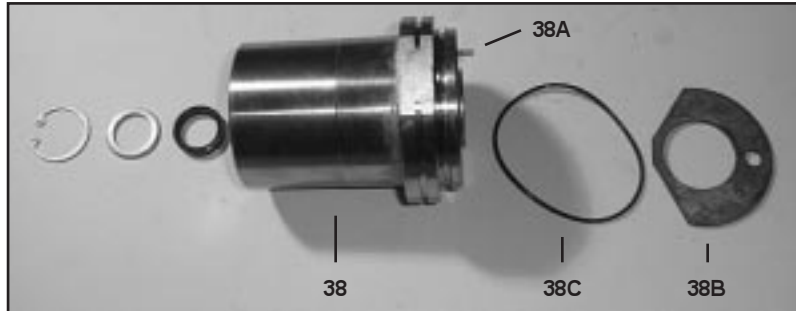

14) Remove circlip ring (48) from seal sleeve (38). Remove spacer disc (47) and seal ring (46) from seal sleeve. Replace worn or damaged parts.

15) Remove leakage gasket (38B) from serrated pin (38A) on the seal sleeve (38). Check o-ring (38C) for damage and replace if necessary. **IMPORTANT!** The 3.2 mm (diameter bore of the leakage gasket (38B) must be inserted directly on the serrated pin (38A) of the seal sleeve (38). The leakage gasket must fit snugly to the seal so that the bevelled surface of the gasket faces outwards.

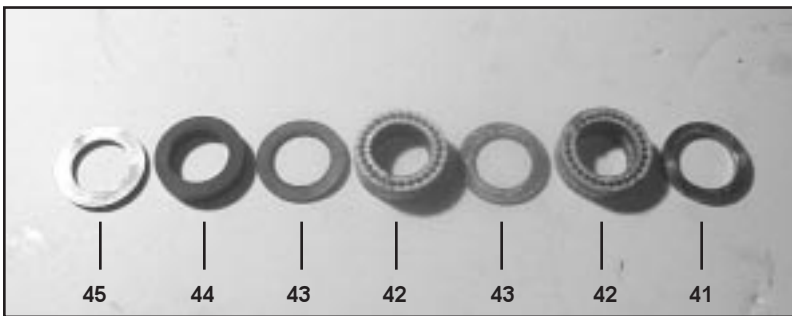

16) Remove support disc (41) seal unit (42, 43, 44) and pressure ring (45) of seal sleeve (38). Examine seals for signs of wear or cavitation, and if necessary, replace.

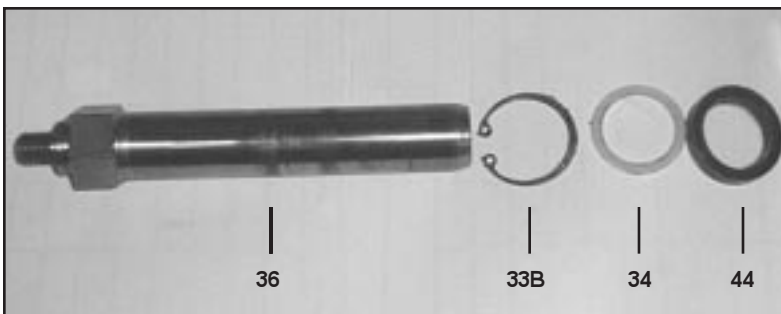

17) Examine plunger (36) for signs of wear or cavitation. If the surface of the plunger is worn, screw out the plunger with a 27mm tool. Clean centering and front surface of crosshead with plunger (25). Thread new plunger carefully through oiled seals in seal sleeve. Coat thread of new plunger lightly with bonding agent (e.g., loctite).

**NOTE:** Seal life can be increased if the pretensioning allows for a little leakage. This assists lubrication and keeps the seals cool. It is therefore not necessary to replace seals before the leakage becomes too heavy and causes output and operating pressure to drop.

### TO ASSEMBLE VALVE CASING

18. Check O-rings (39A) and support rings (39B) on seal case (39). Clean surfaces of seal sleeves (38) in crankcase (1) and sealing surfaces of valve casing (50). Insert seal sleeve with plunger into crankcase guide. Turn crankshaft to (22) until plunger with crosshead (25) pushes against plunger tighten plunger (36) to 26 ft-lbs.

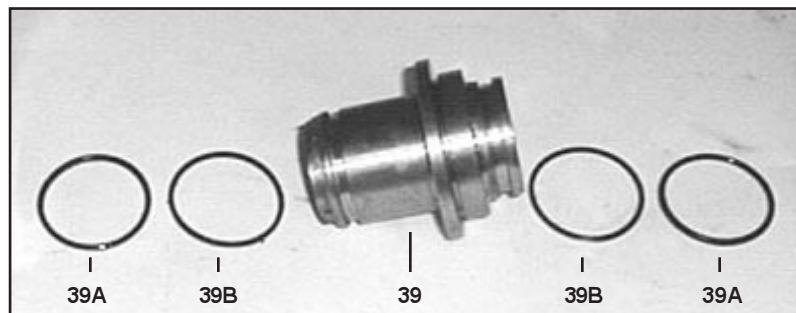

19. Push valve casing carefully over O-rings of seal case and centering studs (50A). Tighten nuts (49A) to space 103 ft-lbs.

### TO DISASSEMBLE GEAR END

20. Take out plunger (36) and seal sleeves (38) as described above. Drain oil.
21. After removing the circlip ring (33B), pry out seal adapter (33) with a screw driver
22. Check seals (32,32A,33A) and surfaces of plunger base (25).
23. Remove crankcase cover (4). Loosen inner hexagon screws (24A) on the connecting rods (24) and push con rod halves as far into the crosshead guide as possible.

**CAUTION:** Connecting rods (24) are marked for identification. Do not twist connecting rod halves. Connecting rod is to be reinstalled in the same position on crankshaft journals.

24. Check surfaces of the connecting rod (24) and crankshaft (22).
25. Take out bearing cover (14) to one side and push out crankshaft (22) taking particular care that the connecting rod (24) doesn't bend.

**CAUTION:** Ring (32A) must always be installed so that the seal-lip on the inside diameter faces the oil.

26. Reassemble in reverse order: Regulate axial bearing clearance - minimum 0.1mm, maximum 0.15mm-by means of fitting disc (20A). The crankshaft (22) should turn easily with little clearance. Tighten inner hexagon screws (24A) to 30 ft.-lbs.

**CAUTION:** Connecting rod (24) has to be able to be slightly moved sidewise at the stroke journals.

27. Reassemble cover (4) and seal (5) onto crankcase (1). Fasten with hexagon screws (10).
28. Reinstall shim (33C), and seal adaptor (33) with radial shaft seal (32), ring (32A) and o-ring (33A) onto crankcase (1).
29. Reinstall remainder of fluid end as described above in "To Assemble Valve Casing" section (21 and 22 above).

# GP7122 Dimensions (Inches)

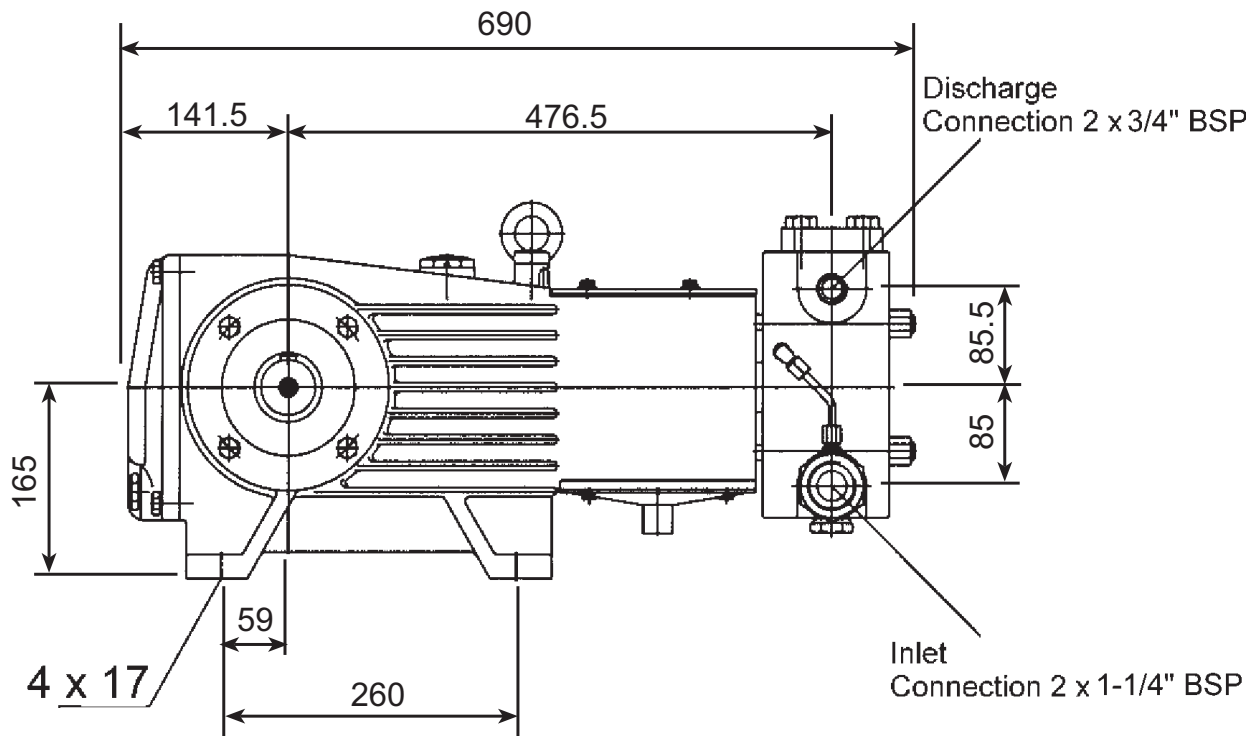
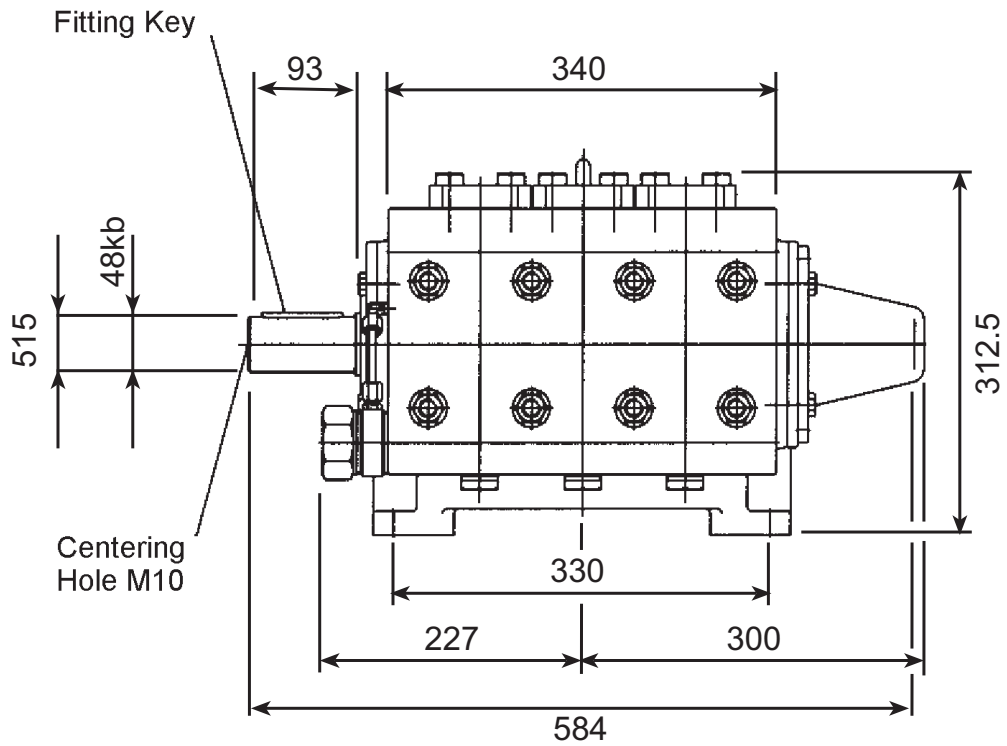

## GIANT INDUSTRIES LIMITED WARRANTY

Giant Industries, Inc. pumps and accessories are warranted by the manufacturer to be free from defects in workmanship and material as follows:

1. For portable pressure washers and car wash applications, the discharge manifolds will never fail, period. If they ever fail, we will replace them free of charge. Our other pump parts, used in portable pressure washers and in car wash applications, are warranted for five years from the date of shipment for all pumps used in NON-SALINE, clean water applications.
2. One (1) year from the date of shipment for all other Giant industrial and consumer pumps.
3. Six (6) months from the date of shipment for all rebuilt pumps.
4. Ninety (90) days from the date of shipment for all Giant accessories.

This warranty is limited to repair or replacement of pumps and accessories of which the manufacturer's evaluation shows were defective at the time of shipment by the manufacturer. The following items are NOT covered or will void the warranty:

1. Defects caused by negligence or fault of the buyer or third party.
2. Normal wear and tear to standard wear parts.
3. Use of repair parts other than those manufactured or authorized by Giant.
4. Improper use of the product as a component part.
5. Changes or modifications made by the customer or third party.
6. The operation of pumps and or accessories exceeding the specifications set forth in the Operations Manuals provided by Giant Industries, Inc.

Liability under this warranty is on all non-wear parts and limited to the replacement or repair of those products returned freight prepaid to Giant Industries which are deemed to be defective due to workmanship or failure of material. A Returned Goods Authorization (R.G.A.) number and completed warranty evaluation form is required prior to the return to Giant Industries of all products under warranty consideration. Call (419)-531-4600 or fax (419)-531-6836 to obtain an R.G.A. number.

Repair or replacement of defective products as provided is the sole and exclusive remedy provided hereunder and the MANUFACTURER SHALL NOT BE LIABLE FOR FURTHER LOSS, DAMAGES, OR EXPENSES, INCLUDING INCIDENTAL AND CONSEQUENTIAL DAMAGES DIRECTLY OR INDIRECTLY ARISING FROM THE SALE OR USE OF THIS PRODUCT.

THE LIMITED WARRANTY SET FORTH HEREIN IS IN LIEU OF ALL OTHER WARRANTIES OR REPRESENTATION, EXPRESS OR IMPLIED, INCLUDING WITHOUT LIMITATION ANY WARRANTIES OR MERCHANTABILITY OR FITNESS FOR A PARTICULAR PURPOSE AND ALL SUCH WARRANTIES ARE HEREBY DISCLAIMED AND EXCLUDED BY THE MANUFACTURER.

