

Model CP420/CP425

Triplex Ceramic
Plunger Pump
Operating Instructions/
Repair and Service
Manual

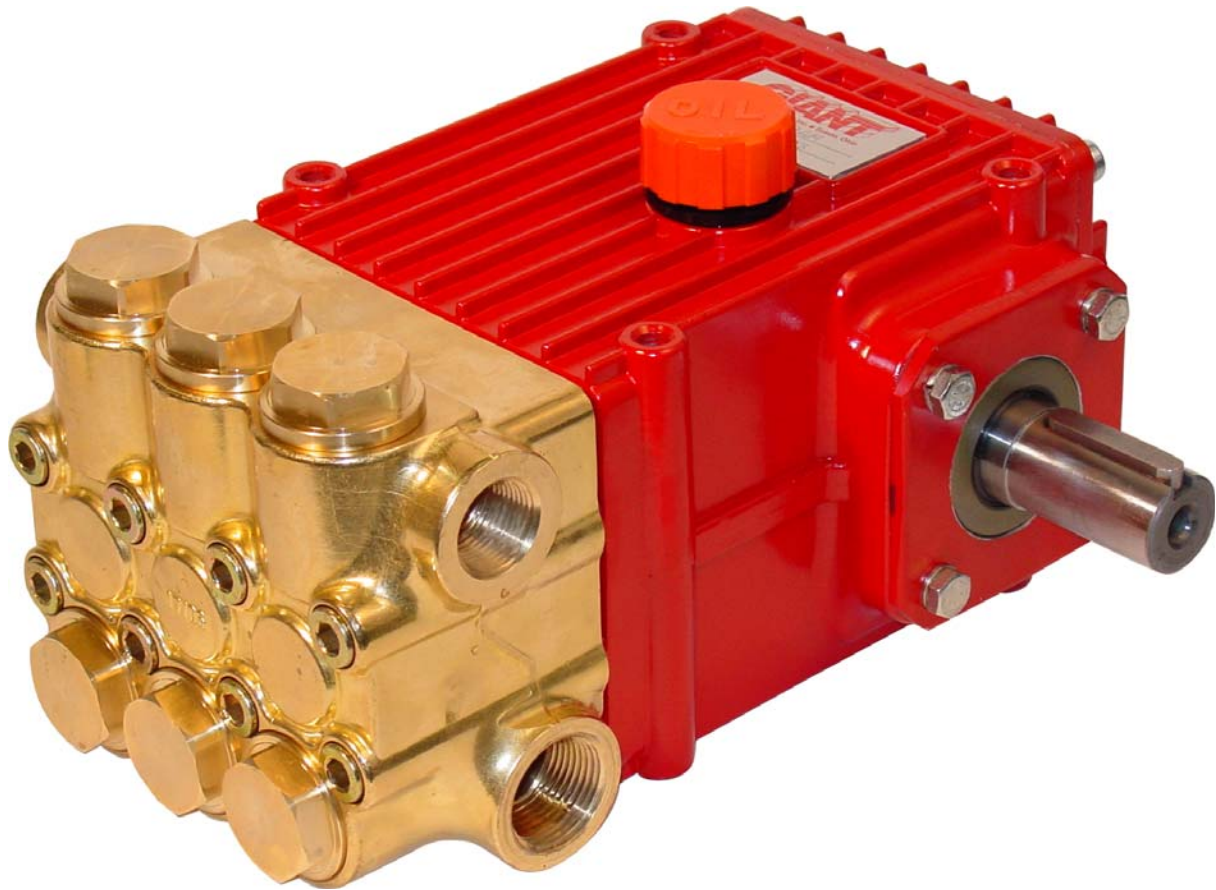

The logo for GIANT, featuring the word "GIANT" in a bold, black, sans-serif font with a 3D effect where the letters are stacked on top of each other.

Updated 02/12

Contents:

Installation Instructions:	page 2
Pump Specifications:	page 3
Exploded View:	page 4
Part List/Kits:	page 5
Torque Specifications:	page 5
Repair Instructions:	pages 6-7
Dimensions:	back page
Warranty Information	back page

INSTALLATION INSTRUCTIONS

Installation of the Giant Industries, Inc., pump is not a complicated procedure, but there are some basic steps common to all pumps. The following information is to be considered as a general outline for installation. If you have unique requirements, please contact Giant Industries, Inc. or your local distributor for assistance.

1. The pump should be installed flat on a base to a maximum of a 15 degree angle of inclination to ensure optimum lubrication.
2. The inlet to the pump should be sized for the flow rate of the pump with no unnecessary restrictions that can cause cavitation. Teflon tape should be used to seal all joints. If pumps are to be operated at temperatures in excess of 160° F, it is important to insure a positive head to the pump to prevent cavitation.
3. The discharge plumbing from the pump should be properly sized to the flow rate to prevent line pressure loss to the work area. It is essential to provide a safety bypass valve between the pump and the work area to protect the pump from pressure spikes in the event of a blockage or the use of a shut-off gun.

4. Use of a dampener is necessary to minimize pulsation at drive elements, plumbing, connections, and other system areas. The use of a dampener with Giant Industries, Inc. pumps is optional, although recommended by Giant Industries, Inc. to further reduce system pulsation. Dampeners can also reduce the severity of pressure spikes that occur in systems using a shut-off gun. A dampener must be positioned downstream from the unloader.

5. Crankshaft rotation on Giant Industries, Inc. pumps should be made in the direction designated by the arrows on the pump crankcase. Reverse rotation may be safely achieved by following a few guidelines available upon request from Giant Industries, Inc. Required horsepower for system operation can be obtained from the chart on page 3.

6. Before beginning operation of your pumping system, remember: Check that the crankcase and seal areas have been properly lubricated per recommended schedules. Do not run the pump dry for extended periods of time. Cavitation will result in severe damage. Always remember to check that all plumbing valves are open and that pumped media can flow freely to the inlet of the pump.

Finally, remember that high pressure operation in a pump system has many advantages. But, if it is used carelessly and without regard to its potential hazard, it can cause serious injury.

IMPORTANT OPERATING CONDITIONS

Failure to comply with any of these conditions invalidates the warranty.

1. Prior to initial operation, add oil to the crankcase so that oil level is between the two lines on the oil dipstick. **DO NOT OVERFILL.**

For CO₂ temperatures in excess of 32 °F (0 °C), use Giant Oil (p/n 01153) or its equivalent (SAE 20W-50). For CO₂ temperatures in less than 32 °F (0 °C), use SAE 0W-40.

Crankcase oil should be changed after the first 50 hours of operation, then at regular intervals of 500 hours or less depending on

operating conditions.

2. Pump operation must not exceed rated pressure, volume, or RPM. A pressure relief device must be installed in the discharge of the system.

3. Acids, alkalines, or abrasive fluids cannot be pumped unless approval in writing is obtained before operation from Giant Industries, Inc.

4. Run the pump dry approximately 10 seconds to drain the water before exposure to freezing temperatures.

Specifications Model CP420

	U.S.	Metric
Volume	6.42 GPM	24.2 LPM
Discharge Pressure	1740 PSI	120 Bar
Inlet Pressure	14-500 PSI	1-35 Bar
Stroke	0.98"	24mm
Speed		Up to 750 RPM
Plunger Diameter	1.02"	25mm
Temperature of Pumped Fluids	-40 °F to 160 °F	-40 °C to 70 °F
Inlet Ports		(2) x 1" BSP
Discharge Ports		(2) x 3/4" BSP
Shaft Rotation		Top of pulley towards fluid end
Crankshaft Diameter	1.10"	28mm
Key Width	0.31"	8mm
Shaft Mounting		Either side ¹
Weight	36.6 lbs.	16.6 KG
Crankcase Capacity	30fl.oz.	1 Liter

Consult the factory for special requirements that must be met if the pump is to operate beyond one or more of the limits specified above.

¹NOTES:

In order to drive the pump from the side opposite the present shaft extension, simply remove the valve casing from the crankcase and rotate the pumps 180 degrees to the desired position. Be certain to rotate the seal case (item #20) as well, so that the weep holes are down at the six o'clock position. Exchange the oil fill and the oil drain plugs, also. Refer to the repair instructions as necessary for the proper assembly sequence.

CP420 HORSEPOWER REQUIREMENTS					
RPM	GPM	500 PSI	1000 PSI	1500 PSI	1740 PSI
350	3.00	1.0	2.1	3.1	3.6
450	3.85	1.3	2.7	4.0	4.6
550	4.71	1.6	3.2	4.9	5.6
650	5.56	1.9	3.8	5.8	6.7
750	6.42	2.2	4.4	6.6	7.7

HORSEPOWER RATINGS:

The rating shown are the power requirements for the pump. Gas engine power outputs must be approximately twice the pump power requirements shown above.

We recommend a 1.15 service factor be specified when selecting an electric motor as the power source. To compute specific pump horse power requirements, use the following formula:

$$HP = (GPM \times PSI) / 1450$$

Exploded View - CP420/CP425 Pump

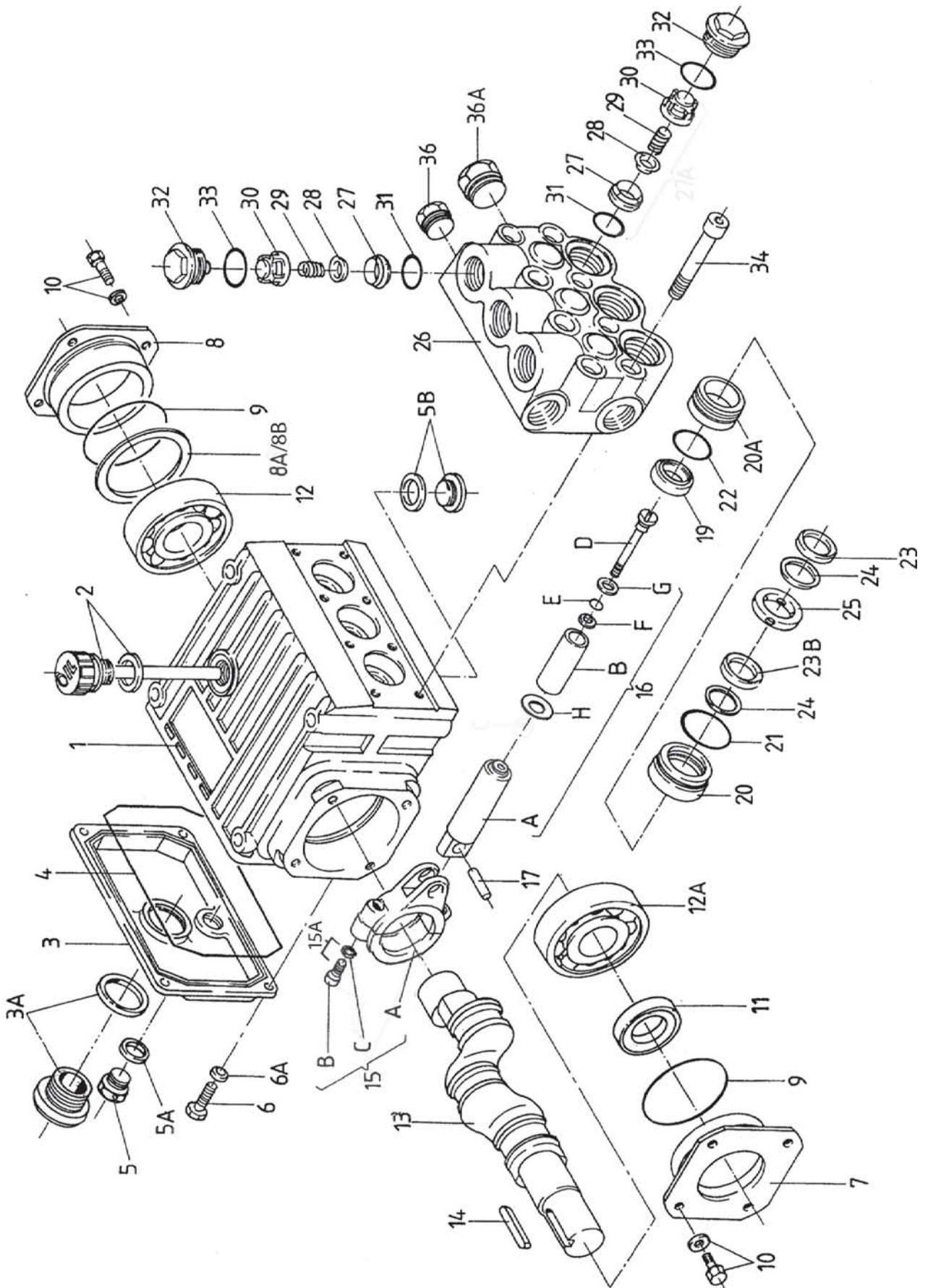

CP420/CP425 PUMP PARTS LIST

<u>ITEM</u>	<u>PART</u>	<u>DESCRIPTION</u>	<u>QTY.</u>	<u>ITEM</u>	<u>PART</u>	<u>DESCRIPTION</u>	<u>QTY.</u>
1	08377	Crankcase	1	16D	08399	Tension Screw	3
2	08378	Oil Fill Plug with Gasket	1	16E	07023	O-Ring	3
3	06479	Crankcase cover	1	16F	07203	Backup Ring	3
3A	07186	Oil Sight Glass w/ Gasket	1	16G	07258	Copper Washer	3
4	08380	O-Ring	1	16H	06431	Oil Scraper	3
5	07109	Oil Drain Plug	1	17	06790	Crosshead Pin	3
5A	07182	Gasket for Oil Drain Plug	1	19	08366	Oil Seal	3
5B	08092	Plug with Gasket	1	20	06771	Seal Case	3
6	01010	Screw	4	20A	06772	Gear Seal Adapter	3
6A	01010-0400	Spring Washer	4	21*	07266-0003	O-Ring, EPDM	3
7	05290	Bearing Cover	1	22	08059	O-Ring	3
8	05291	Bearing Cover	1	23	06144	Grooved Seal, Brown	3
8A	05292	Shim	1	23B	12255-0020	Grooved Seal, Teflon	3
8B	05293	Shim (May not be present)	1	24	08376	Pressure Ring	6
9	01016	O-Ring	2	25	08394	Weep Return Ring	3
10	07114	Screw with Washer	8	26	06999	Manifold, Brass	1
11	07459	Radial Shaft Seal	1	27	08370	Valve Seat	6
12	05350	Bearing	2	28	06791-0100	Valve Plate, 316 S.S.	6
13	08475	Crankshaft (CP420)	1	29	06377-0100	Valve Spring, 316 S.S.	6
13	08482	Crankshaft (CP425)	1	30	08372	Spring Tension Cap	6
14	08091	Fitting Key	1	31*	07212-0003	O-Ring, EPDM	6
15	08390	Connecting Rod Assembly	3	32	08373	Plug	6
15A	07311	Screw with Washer	6	33*	07214-0003	O-Ring, EPDM	6
16	05959	Plunger Assy., 25mm, For items 16A-16G	3	34	08396	Cap Screw	8
16A	05352	Plunger Base	3	36	07703	Plug, 3/4" BSP	1
16B	05960	Plunger Pipe, 25mm	3	36A	12249	Plug, 1" BSP	1

*The O-Rings must not come into contact with mineral oil or mileral grease. Use silicone grease only

CP420/CP425 PUMP REPAIR KITS

Plunger Packing Kit - # 09595

<u>Item</u>	<u>Part #</u>	<u>Description</u>	<u>Qty</u>
21	07266-0003	O-Ring, EPDM	3
22	08059	O-Ring	3
23	06144	Grooved Seal, Brown	3
23B	12255-0020	Grooved Seal, Teflon	3
24	08376	Pressure Ring	6

Valve Assembly Kit - # 09596

<u>Item</u>	<u>Part #</u>	<u>Description</u>	<u>Qty.</u>
27	08370	Valve Seat	6
28	06791-0100	Valve Plate, 316 S.S.	6
29	06377-0100	Valve Spring, 316 S.S.	6
30	08372	Spring Tension Cap	6
31	07212-0003	O-Ring, EPDM	6
33	07214-0003	O-Ring, EPDM	6

Oil Seal Kit - # 09306

<u>Item</u>	<u>Part #</u>	<u>Description</u>	<u>Qty</u>
19	08366	Oil Seal	3

CP420/CP425 PUMP TORQUE SPECIFICATIONS

<u>Position</u>	<u>Item#</u>	<u>Description</u>	<u>Torque Amount</u>
15A	07311	Screw with Washer	216 in.-lbs.
16D	08399	Tension Screw	240 in.-lbs.
32	08373	Plug	125 ft.-lbs.
34	08396	Cap Screw	35 ft.-lbs.

REPAIR INSTRUCTIONS - CP420/CP425 PUMP

Note: Always take time to lubricate all metal and nonmetal parts with a light film of oil before reassembly. This step will ensure proper fit, at the same time protecting the pump nonmetal parts (i.e., the elastomers) from cutting and scoring.

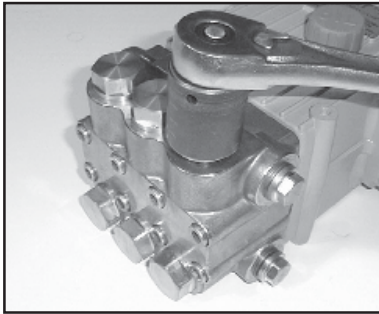

- 1) With a socket wrench, remove the three discharge valve plugs and three inlet valve plugs (32). Inspect the o-ring (33) for wear and replace if damaged.

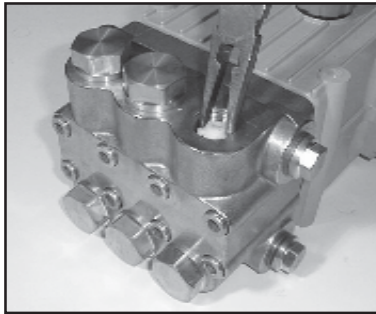

- 2) Using needle nose pliers, remove the inlet and discharge valve assemblies (27-33). Note: It may become necessary to remove the valve seat (27) from the valve casing using a slide hammer.

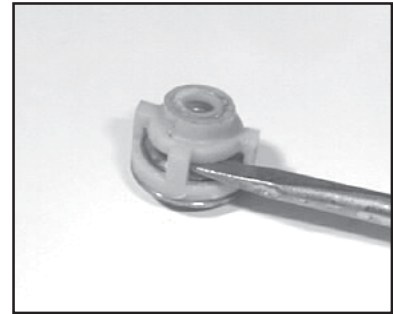

- 3) By inserting a small screw driver between the valve seat (27) and the valve spring retainer (30), the valve assembly can be separated.

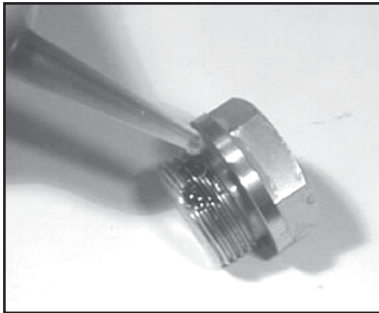

- 4) Remove the o-ring (31). Inspect all parts for wear and replace as necessary. Apply one drop of loctite 243 to the valve plugs (32) and tighten to 125 ft. lbs.

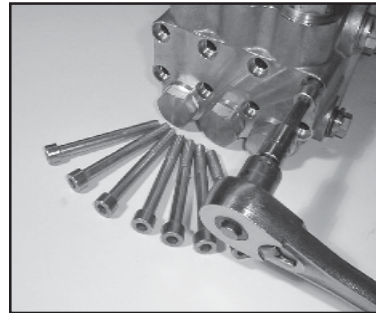

- 5) Use a 8mm allen wrench to remove the 8 socket head cap screws (34). Carefully slide the valve casing (26) out over the plungers.

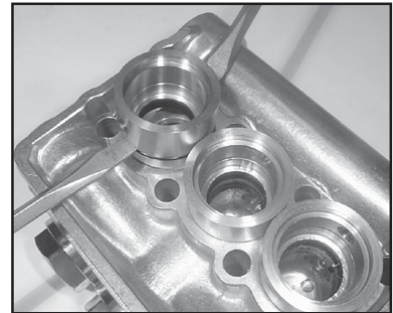

- 6) Remove seal case (20) and weep return rings (25) from the valve casing.

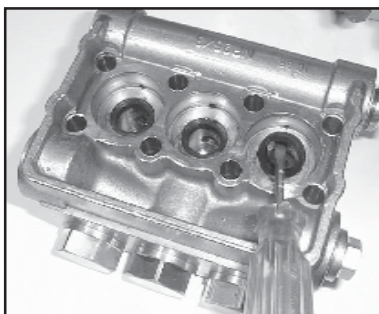

- 7) Remove the pressure rings (24) and grooved seals (23) from the valve casing (26).



- 8) Remove the weep grooved seal (23B) together with pressure ring (24) out of the seal case (20). Check O-rings (21).

IMPORTANT! The grooved seal (23) on the high-pressure side is to be fitted carefully into the valve casing (26) using a screwdriver. Under no circumstances must the seal surface in the valve casing or the seal lip be damaged.

REASSEMBLY INSTRUCTIONS - CP420/CP425 PUMP

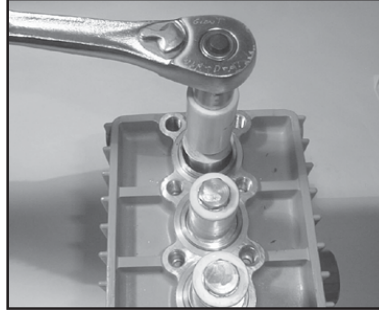
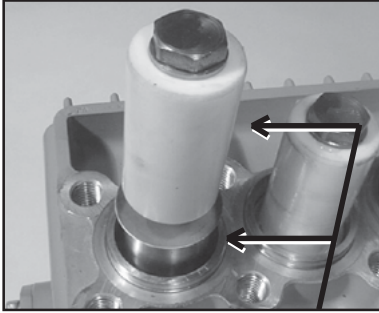

IMPORTANT! Care must be taken that glue does not get between the plunger pipe should not be strained by eccentric tightening of the tension screw or through damage to front surface of plunger, otherwise it is liable to fracture.

- 9) Check surfaces of plunger (16). damaged surfaces cause accelerated seal wear. Deposits of all kinds must be removed from the plungers.

IMPORTANT! plunger surfaces are not to be damaged. If there are lime deposits in the pump, care must be taken that the drip return bore in parts (25) and (26) ensure trouble-free drip-return.

- 10) If the plunger pipe (16B), or oil seal (19) is worn, remove tension screw (16D) and remove along with plunger pipe (16B). Check and clean plunger surface (16A), check oil scraper (16H). Remove the gear seal adapter (20A) and, if necessary, replace oil seals with seal lips facing crankcase (1). If the gear seal adapter is removed, replace the o-ring (22). Cover thread of tension screw (16D) with a thin film of Loctite and tighten carefully to 26 ft.-lbs. (35NM).

- 11) After installation of the high pressure seals (23), place seal case (20) with weep seals & pressure ring installed, weep return ring (25) and high pressure weep return ring (24) over plungers. Slide valve casing over plungers and seat firmly. Replace the 8 socket head cap screws (34) and tighten to 35 ft.-lbs. in a crossing pattern (as shown below).

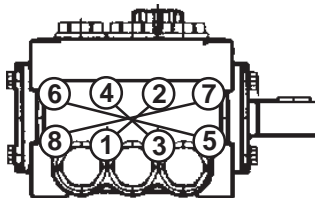

Contact Giant Industries for service school information. Phone: (419) 531-4600

CP420/CP425 PUMP DIMENSIONS - INCHES (mm)

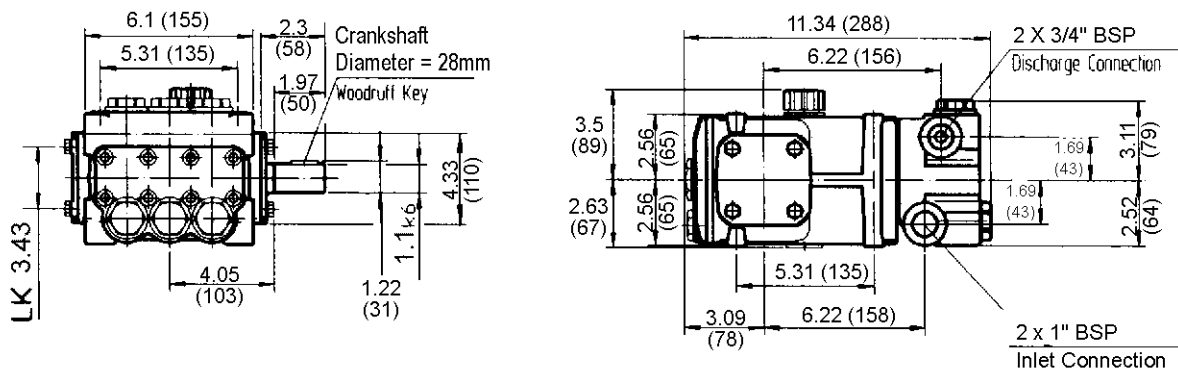

GIANT INDUSTRIES LIMITED WARRANTY

Giant Industries, Inc. pumps and accessories are warranted by the manufacturer to be free from defects in workmanship and material as follows:

1. For portable pressure washers and self-service car wash applications, the discharge manifolds will never fail, period. If they ever fail, we will replace them free of charge. Our other pump parts, used in portable pressure washers and in car wash applications, are warranted for five years from the date of shipment for all pumps used in NON-SALINE, clean water applications.
2. One (1) year from the date of shipment for all other Giant industrial and consumer pumps.
3. Six (6) months from the date of shipment for all rebuilt pumps.
4. Ninety (90) days from the date of shipment for all Giant accessories.

This warranty is limited to repair or replacement of pumps and accessories of which the manufacturer's evaluation shows were defective at the time of shipment by the manufacturer. The following items are NOT covered or will void the warranty:

1. Defects caused by negligence or fault of the buyer or third party.
2. Normal wear and tear to standard wear parts.
3. Use of repair parts other than those manufactured or authorized by Giant.
4. Improper use of the product as a component part.
5. Changes or modifications made by the customer or third party.
6. The operation of pumps and or accessories exceeding the specifications set forth in the Operations Manuals provided by Giant Industries, Inc.

Liability under this warranty is on all non-wear parts and limited to the replacement or repair of those products returned freight prepaid to Giant Industries which are deemed to be defective due to workmanship or failure of material. A Returned Goods Authorization (R.G.A.) number and completed warranty evaluation form is required prior to the return to Giant Industries of all products under warranty consideration. Call (419)-531-4600 or fax (419)-531-6836 to obtain an R.G.A. number.

Repair or replacement of defective products as provided is the sole and exclusive remedy provided hereunder and the MANUFACTURER SHALL NOT BE LIABLE FOR FURTHER LOSS, DAMAGES, OR EXPENSES, INCLUDING INCIDENTAL AND CONSEQUENTIAL DAMAGES DIRECTLY OR INDIRECTLY ARISING FROM THE SALE OR USE OF THIS PRODUCT.

THE LIMITED WARRANTY SET FORTH HEREIN IS IN LIEU OF ALL OTHER WARRANTIES OR REPRESENTATION, EXPRESS OR IMPLIED, INCLUDING WITHOUT LIMITATION ANY WARRANTIES OR MERCHANTABILITY OR FITNESS FOR A PARTICULAR PURPOSE AND ALL SUCH WARRANTIES ARE HEREBY DISCLAIMED AND EXCLUDED BY THE MANUFACTURER.

