

Series CP200

Triplex Ceramic
Plunger Pump
Operating Instructions/
Repair and Service Manual

For Models:

CP218
CP220
CP230

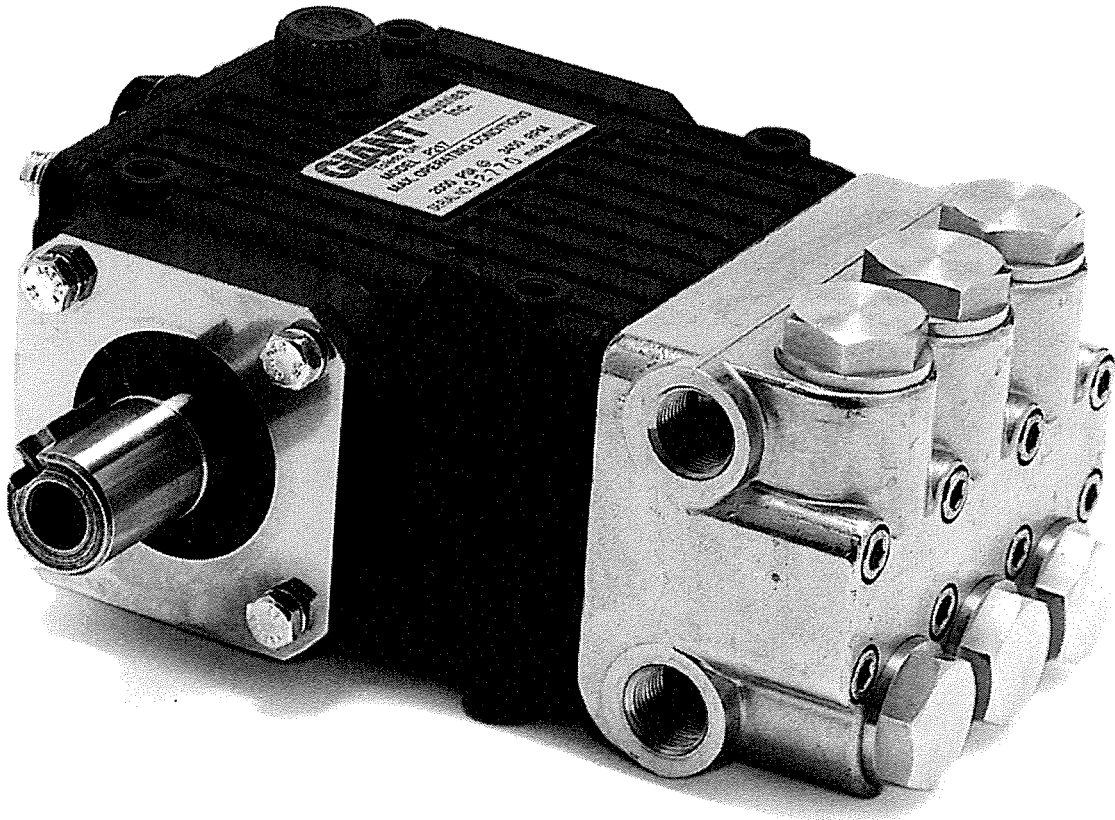

Contents:

Installation Instructions:	page 2
Pump Specifications:	page 3
Exploded View:	page 4
Parts List:	page 4
Repair Kits:	page 5
Torque Specifications:	page 5
Trouble Shooting:	page 5
Repair Instructions:	pages 6-7
Pump Mounting Selection Guide:	page 7
Preventative Maintenance:	page 7
Dimensions:	back page
Warranty Information:	back page

Updated 10/10

INSTALLATION INSTRUCTIONS

Installation of the Giant Industries, Inc., pump is not a complicated procedure, but there are some basic steps common to all pumps. The following information is to be considered as a general outline for installation. If you have unique requirements, please contact Giant Industries, Inc. or your local distributor for assistance.

1. The pump should be installed flat on a base to a maximum of a 15 degree angle of inclination to ensure optimum lubrication.
2. The inlet to the pump should be sized for the flow rate of the pump with no unnecessary restrictions that can cause cavitation. Teflon tape should be used to seal all joints. It is important to insure a positive head to the pump to prevent cavitation.
3. The discharge plumbing from the pump should be properly sized to the flow rate to prevent line pressure loss to the work area. It is essential to provide a safety bypass valve between the pump and the work area to protect the pump from pressure spikes in the event of a blockage or the use of a shut-off gun.

4. **CAUTION** EPDM seals must not come into contact with mineral oil or mineral grease, otherwise they will swell. Use silicon grease only.

5. Crankshaft rotation on Giant Industries, Inc. pumps should be made in the direction designated by the arrows on the pump crankcase. Reverse rotation may be safely achieved by following a few guidelines available upon request from Giant Industries, Inc. Required horsepower for system operation can be obtained from the chart on page 3.

6. Before beginning operation of your pumping system, remember: Check that the crankcase and seal areas have been properly lubricated per recommended schedules. Do not run the pump dry for extended periods of time. Cavitation will result in severe damage. Always remember to check that all plumbing valves are open and that pumped media can flow freely to the inlet of the pump.

Finally, remember that high pressure operation in a pump system has many advantages. But, if it is used carelessly and without regard to its potential hazard, it can cause serious injury.

IMPORTANT OPERATING CONDITIONS

Failure to comply with any of these conditions invalidates the warranty.

1. Prior to initial operation, add oil to the crankcase so that oil level is between the two lines on the oil dipstick. DO NOT OVER-FILL.

Use Synthetic Oil SAE 0W-40

Crankcase oil should be changed after the first 50 hours of operation, then at regular intervals of 500 hours or less depending on operating conditions.

2. Pump operation must not exceed rated pressure, volume, or RPM. A pressure relief device must be installed in the discharge of the system.

3. Acids, alkalines, or abrasive fluids cannot be pumped unless approval in writing is obtained before operation from Giant Industries, Inc.

4. Run the pump dry approximately 10 seconds to drain the water before exposure to freezing temperatures.

CP200 SERIES -- PUMP SPECIFICATIONS

U.S. Measurements

	Max. Flow	Max. Pressure	Max. Speed	Power Req'd.	Max. Temperature	Plunger Diameter	Stroke
Model	GPM	PSI	RPM	HP	F	in	in
CP230	0.5	2030	750	0.7	(-40) to 32	0.71	0.39
CP218	1.4	2030	750	2.0	(-40) to 32	0.71	0.56
CP220	1.9	2030	750	2.7	(-40) to 32	0.71	0.13

Metric Measurements

	Max. Flow	Max. Pressure	Max. Speed	Power Req'd.	Max. Temperature	Plunger Diameter	Stroke
Model	L/min	Bar	RPM	kW	C	mm	mm
CP230	1.8	140	750	0.5	(-40) to 0	18	10.0
CP218	5.3	140	750	1.5	(-40) to 0	18	14.1
CP220	7.3	140	750	2.0	(-40) to 0	18	26.0

Consult the factory for special requirements that must be met if the pump is to operate beyond one or more of the limits specified above.

Horsepower Ratings:

We recommend a 1.15 service factor be specified when selecting an electric motor as the power source.

To compute electric motor horsepower required, use the following formula: $HP = (GPM \times PSI) / 1450$.

The formula to determine the horsepower required for a gas engine is: $HP = (GPM \times PSI) / 1150$.

The formula to determine the horsepower required for a diesel engine is: $HP = (GPM \times PSI) / 1250$.

For the Application of a Hydraulic Motor:

To Determine the Torque of a Hydraulic Motor -- $(GPM \times PSI \times 36.77) / RPM = \text{Torque (in-lbs)}$

Calculating RPM / GPM of Pump:

A pump must be connected to an electric motor or gas or diesel engine with the correct ratio of pulleys and belts to attain the required speed and GPM. The use of a Variable Frequency Drive (VFD) may also be used to control the RPM of a properly sized electric motor when variable flows are required.

$$(\text{Max. Pump RPM} / \text{Rated Pump GPM}) \times \text{Required Pump GPM} = \text{Required Pump RPM}$$

To calculate a pulley diameter one (1) pulley diameter and the required pump RPM must be known:

$$(\text{Pump RPM} \times \text{Pump Pulley Diameter}) / \text{Motor RPM} = \text{Motor Pulley Diameter}$$

$$(\text{Motor RPM} \times \text{Motor Pulley Diameter}) / \text{Pump RPM} = \text{Pump Pulley Diameter}$$

Common Specifications:

Inlet Pressure.....	580 PSI (40 Bar)
Crankshaft Diameter.....	0.94" (24mm)
Crankcase Oil Capacity.....	7.5 fl. oz. (222 ml)
Inlet Ports.....	(2) 3/8" BSP
Discharge Ports.....	(2) 3/8" BSP
Weight.....	11 lbs 11 oz (5.4kg)
Shaft Rotation.....	Top of Pulley Toward Fluid End

Materials Used for CP200 Pumps:

Manifold	Forged Brass
Plungers	Solid Ceramic Oxide
Valves	High Grade Stainless Steel
Seals	Teflon and Nitrile with Fabric Reinforcing
Gear End	Aluminum

Exploded View - CP200 Series

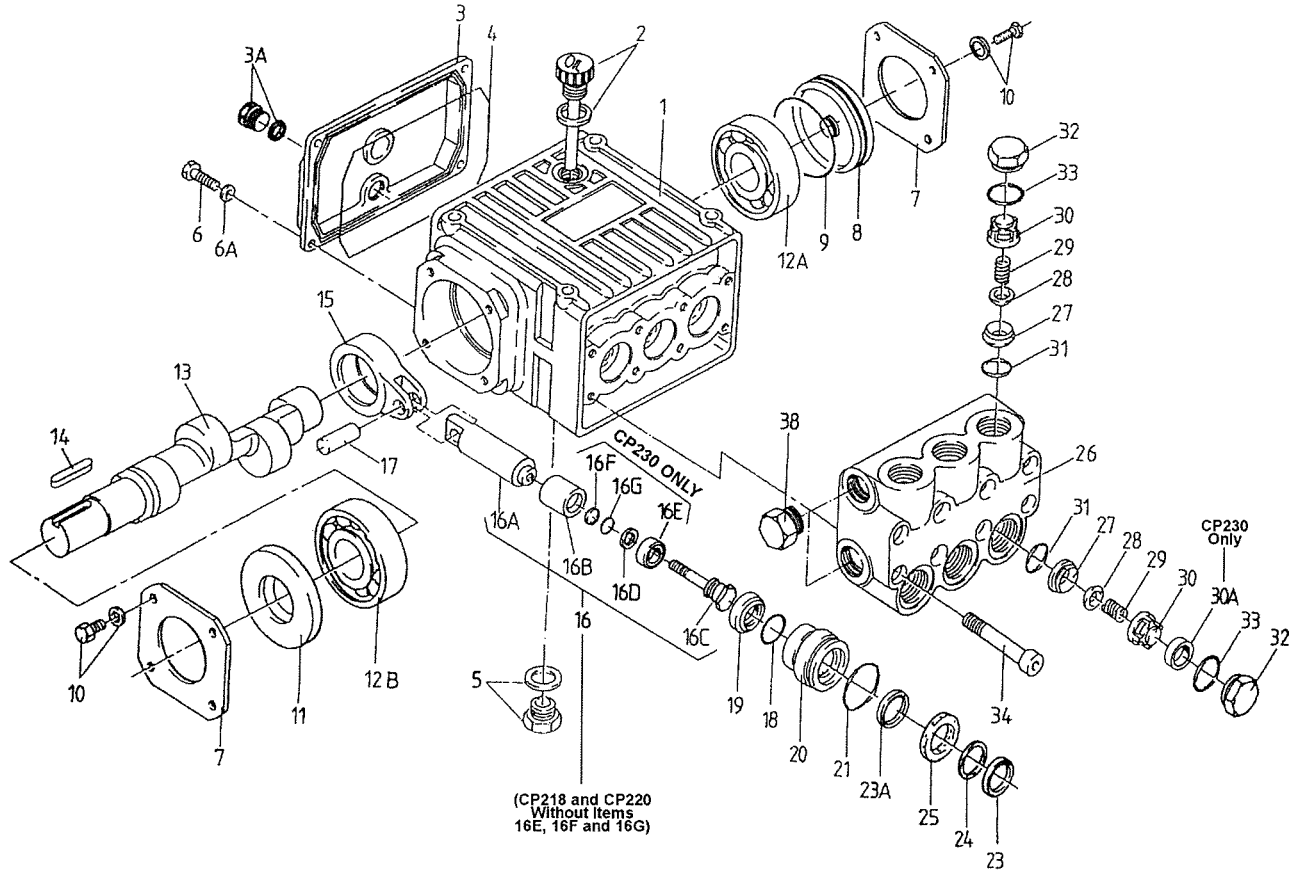

Spare Parts

Item	Part No.	Description	Qty.	Item	Part No.	Description	Qty.
1	05452	Crankcase	1	16D	07676	Copper Gasket (CP218, CP220)	3
2	08301	Oil Dipstick with O-Ring	1	16D	07204-0100	Copper Gasket (CP230 only)	3
3	08302A	Crankcase Cover, Short	1	16E	06823	Plunger Extension (CP230 only)	3
3A	07190	Drain Plug & Gasket	1	16F	07203	Support Ring (CP230 only)	3
4	08005	O-Ring	1	16G	07023	O-Ring (CP230 only)	3
5	06273	Oil Drain Plug	1	17	08442	Wrist Pin	3
5A	08192	Gasket	1	18	07770	O-Ring	3
6	07188	Screw, Crankcase Cover	4	19	08356-0010	Oil Seal	3
6A	07223	Spring Washer	4	20	08444	Seal Case	3
7	08303	Bearing Cover I	2	21	06815	O-Ring	3
8	08490	Oil Sight Glass	1	23	08087	V-Sleeve, Weep	3
9	08492	O-Ring	1	23A	08087-0020	V-Sleeve, Teflon	3
10	07225	Screw with Lock Washer	8	24	07904	Pressure Ring	3
11	01166	Radial Shaft Seal	1	25	08445	Weep Return Ring	3
12A	08020	Ball Bearing	1	26	08446	Valve Casing	1
12B	01020	Ball Bearing	1	27	07849	Valve Seat	6
13	08440	Crankshaft (CP218)	1	28	06809	Valve Plate	6
13	08467	Crankshaft (CP220)	1	29	06816	Valve Spring	6
13	06694	Crankshaft (CP230)	1	30	07907	Valve Spring Retainer	6
14	06207	Woodruff Key	1	30A	06824	Spacer Ring (CP230 only)	3
15	08333	Connecting Rod	3	31	06817	O-Ring	6
16	08469	Plunger, Complete, 18mm (CP218, CP220)	3	32	07928	Valve Plug	6
16A	08468	Plunger Base	3	32X	06825	Valve Assembly	6
16B	08455	Plunger Pipe	3	33	06818	O-Ring	6
16C	08456	Tension Screw	3	34	08316	Hex Head Cap Screw	8
				38	13338	Plug, 3/8" BSP	1

Repair Kits - CP200 Series

Valve Assembly Kit

Part # 09556

Item #	Part #	Description	Qty.
32X	06825	Valve Assembly, Complete	6
33	06818	O-Ring	6

Oil Seal Kit

Part # 09144

Item #	Part #	Description	Qty.
19	08356-0010	Oil Seal	3

Plunger Packing Kit

Part # 09554

Item #	Part #	Description	Qty.
23	08087	V-Sleeve, weep	3
23A	08087-0020	V-Sleeve, brown	3
24	07904	Pressure Ring	3

Pump Torque Specifications

Position	Item#	Description	Torque Amount
16C	08456	Tension Screw, Plunger	220 (in.-lbs.)
32	07928	Valve Plug	59 (ft.-lbs.)
34	08316	Hex Head Cap Screw, Valve Casing	105 (in.-lbs.)

Pump System Malfunction

<u>MALFUNCTION</u>	<u>CAUSE</u>	<u>REMEDY</u>
The Pressure and/ or the Delivery Drops	Worn packing seals Broken valve spring Belt slippage Worn or Damaged nozzle Fouled discharge valve Fouled inlet strainer Worn or Damaged hose Worn or Plugged relief valve on pump Cavitation Unloader	Replace packing seals Replace spring Tighten or Replace belt Replace nozzle Clean valve assembly Clean strainer Repair/Replace hose Clean, Reset, and Replace worn parts Check suction lines on inlet of pump for restrictions Check for proper operation
Water in Crankcase	High humidity Worn seals	Reduce oil change interval Replace seals
Noisy Operation	Worn bearings Cavitation	Replace bearings, Refill crankcase oil with recommended lubricant Check inlet lines for restrictions and/or proper sizing
Rough/Pulsating Operation with Pressure Drop	Worn packing Inlet restriction Accumulator pressure Unloader Cavitation	Replace packing Check system for stoppage, air leaks, correctly sized inlet plumbing to pump Recharge/Replace accumulator Check for proper operation Check inlet lines for restrictions and/or proper size
Pump Pressure as Rated, Pressure Drop at Gun	Restricted discharge plumbing	Re-size discharge plumbing to Flow rate of pump.
Excessive Leakage	Worn plungers Worn packing/seals Excessive vacuum Cracked plungers Inlet pressure too high	Replace plungers Adjust or Replace packing seals Reduce suction vacuum Replace plungers Reduce inlet pressure
High Crankcase Temperature	Wrong Grade of oil Improper amount of oil in crankcase	Giant oil is recommended Adjust oil level to proper amount

REPAIR INSTRUCTION - CP200 PUMPS

CAUTION EPDM seals must not come into contact with mineral oil or mineral grease, otherwise they will swell.

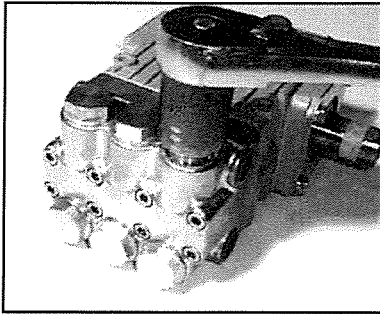

1. With a 22mm socket wrench, remove the (3) discharge valve plugs and (3) inlet valve plugs (32). Inspect the o-ring (33) for wear and replace if damaged.

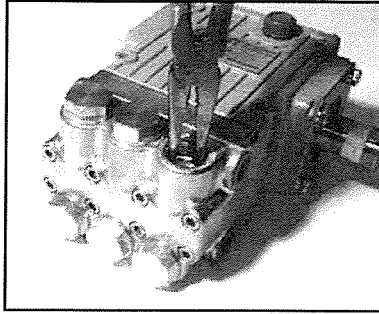

2. Using a needle nose pliers, remove the inlet and discharge valve assemblies (27-30). For P230-3100 only, remove spacer (30A), and o-ring (31). Inspect all parts for wear and replace as necessary.

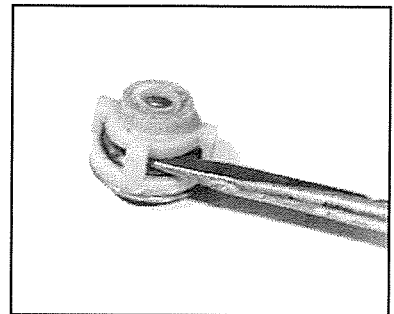

3. By inserting a small screw driver between the valve seat (27) and the valve spring retainer (30), the valve assembly can be separated.

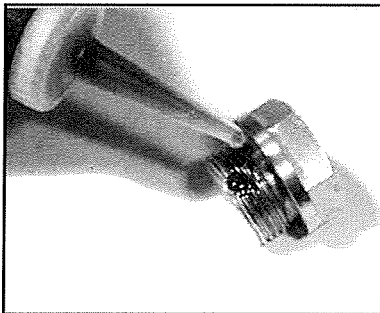

4. Apply one drop of Loctite 243 to the valve plugs (32) and tighten to 33 ft.-lbs.

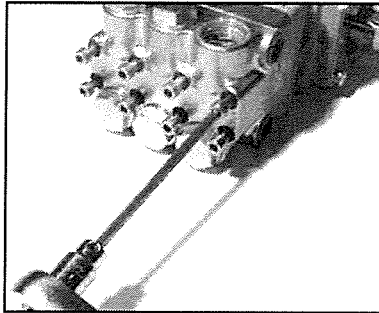

5. Next, use a 5mm allen wrench to remove the 8 socket head cap screws (34).

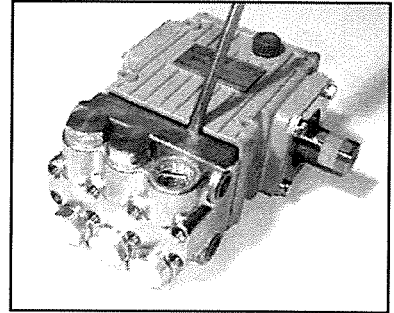

6. Carefully slide the valve casing (26) out over the plungers.

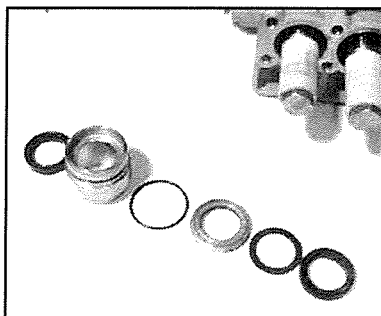

7. Remove the weep return ring (25), pressure ring (24), and v-sleeve (23) from the valve casing (26). Remove the rear v-sleeve (23A) from the seal case (20). Inspect all parts, including o-ring (21) for wear and replace as necessary.

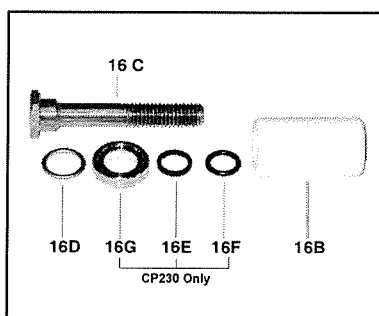

8. Check surfaces of plunger pipe (16B). A damaged surface will cause accelerated wear on the seals. Deposits of any kind must be carefully removed from the plunger surface. A damaged plunger must be replaced!

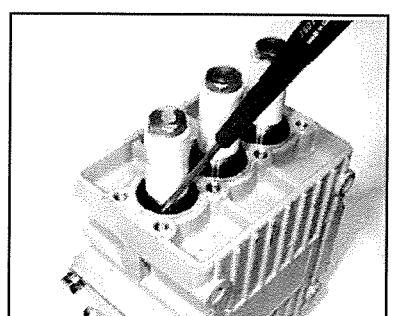

9. If the crankcase oil seals (19) are to be replaced, they can be removed by prying loose with a flat screwdriver. Take care not to make contact with the plunger.

REPAIR INSTRUCTIONS - CP200

Disassembly sequence of the *back* end of the CP200 series pump.

- 1) Before you begin, drain the oil from the crankcase.
- 2) Remove the crankcase cover (3) and o-ring (4) from the crankcase (1). To remove the crankshaft (13), remove the bearing cover (7) and sight glass (8). Using a rubber mallet, remove the crankshaft axially through the connecting rods by tapping on the end of the shaft. Be careful not to bend or damage the connecting rods during crankshaft removal.
- 3) If the bearings (12A and 12B) and radial shaft seal (11) are still in the crankcase, remove them. Inspect both bearings and seal for wear and replace if necessary.
- 4) Remove the connecting rod (15) and plunger assembly (16). Remove the wrist pin (17) if necessary. Check the plunger bore in the crankcase for wear. Inspect parts and replace as necessary.
- 5) Should you find it necessary to service the plunger assembly (16) you can do so by removing the tension screw (16C). Replace crush washer (16D).

NOTE: Carefully flatten crush washer before replacing it. Inspect all parts and replace as necessary.

Reassembly sequence of the CP200 series pump

- 1) Reassemble plunger assembly (16) (apply a drop of Loctite to the tension screw (16C) threads) and the connecting rod (15) with wrist pin (17). Place assemblies in crankcase (1). Install crankshaft through connecting rods again being careful not to bend or otherwise damage the connecting rods.
- 2) Replace left and right side bearings (12A and 12B) if they were removed from the crankshaft. Be certain the bearings are pressed all the way onto the shaft and completely into the crankcase. Replace radial shaft seal (11), bearing cover (7), sight glass (8), and crankcase cover (3) with its o-ring (4).
- 3) If oil seals (19) were removed, replace with seal lip towards crankcase. Lubricate seal before replacing.
- 4) Replace seal case (20) with o-rings (21) over plungers. Generously lubricate o-rings and oil seal before reassembly. Replace drip shield (23B) and v-sleeve (23A) over plungers (16).
- 5) Generously lubricate v-sleeve (23) and assemble into valve casing (26). Assemble weep return ring (25) and pressure ring (24) over plungers (16). Slide valve casing over plungers and seat firmly. Replace the eight socket head cap screws (34) and tighten to 105 inch-pounds in a crossing pattern (see below).
- 6) Re-install the six o-rings (31) and the six valve assemblies (27-30). For CP230, install spacer ring (30A) in front of the inlet valves. Now replace the six valve plugs with o-rings (32 and 33) and tighten securely with a 22mm socket wrench to 33 foot-pounds.
- 7) Fill crankcase with 8.1 ounces of oil.

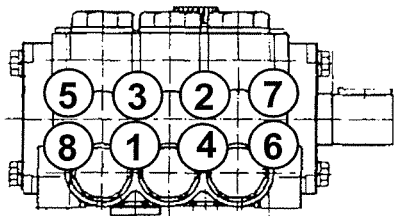

Pump Mounting Selection Guide

Bushings
01074 - 24 mm Tapered H Bushing
Pulley & Sheaves
01061 - 7.75" Cast Iron -1 gr. - AB Section
01062 - 7.75" Cast Iron -2 gr. - AB Section
Rails
01160 - Plated Steel Channel Rails (L=5.75"x W=1.00"x h=2.50")
01161 - Plated Steel Channel Rails (L=5.75"x W=1.00"x H=2.50")

Preventative Maintenance Check List & Recommended Spare Parts List						
Check	Daily	Weekly	50 Hrs.	Every	Every	Every
				500 Hours	1500 Hours	3000 Hours
Oil Level/Quality	X					
Oil Leaks	X					
Water Leaks	X					
Belts, Pulley		X				
Plumbing		X				
Recommended Spare Parts						
Oil Change See page 2			X	X		
Plunger Packing Kit (1 kit/pump) See page 5					X	
Oil Seal Kit (1 kit/pump) See page 5					X	
Valve Repair Kit (1 kit/pump) See page 5						X

CP200 SERIES DIMENSIONS - inches (mm)

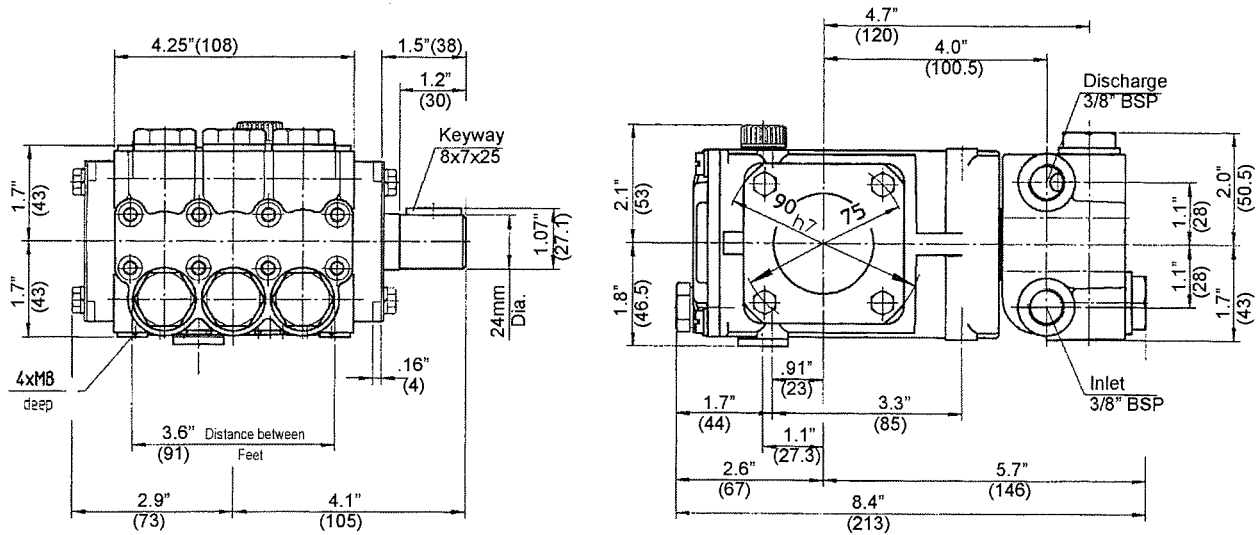

GIANT INDUSTRIES LIMITED WARRANTY

Giant Industries, Inc. pumps and accessories are warranted by the manufacturer to be free from defects in workmanship and material as follows:

1. For portable pressure washers and self-serve car wash applications, the discharge manifolds will never fail, period. If they ever fail, we will replace them free of charge. Our other pump parts, used in portable pressure washers and in car wash applications, are warranted for five years from the date of shipment for all pumps used in NON-SALINE, clean water applications.
2. One (1) year from the date of shipment for all other Giant industrial and consumer pumps.
3. Six (6) months from the date of shipment for all rebuilt pumps.
4. Ninety (90) days from the date of shipment for all Giant accessories.

This warranty is limited to repair or replacement of pumps and accessories of which the manufacturer's evaluation shows were defective at the time of shipment by the manufacturer. The following items are NOT covered or will void the warranty:

1. Defects caused by negligence or fault of the buyer or third party.
2. Normal wear and tear to standard wear parts.
3. Use of repair parts other than those manufactured or authorized by Giant.
4. Improper use of the product as a component part.
5. Changes or modifications made by the customer or third party.
6. The operation of pumps and or accessories exceeding the specifications set forth in the Operations Manuals provided by Giant Industries, Inc.

Liability under this warranty is on all non-wear parts and limited to the replacement or repair of those products returned freight prepaid to Giant Industries which are deemed to be defective due to workmanship or failure of material. A Returned Goods Authorization (R.G.A.) number and completed warranty evaluation form is required prior to the return to Giant Industries of all products under warranty consideration. Call (419)-531-4600 or fax (419)-531-6836 to obtain an R.G.A. number.

Repair or replacement of defective products as provided is the sole and exclusive remedy provided hereunder and the MANUFACTURER SHALL NOT BE LIABLE FOR FURTHER LOSS, DAMAGES, OR EXPENSES, INCLUDING INCIDENTAL AND CONSEQUENTIAL DAMAGES DIRECTLY OR INDIRECTLY ARISING FROM THE SALE OR USE OF THIS PRODUCT.

THE LIMITED WARRANTY SET FORTH HEREIN IS IN LIEU OF ALL OTHER WARRANTIES OR REPRESENTATION, EXPRESS OR IMPLIED, INCLUDING WITHOUT LIMITATION ANY WARRANTIES OR MERCHANTABILITY OR FITNESS FOR A PARTICULAR PURPOSE AND ALL SUCH WARRANTIES ARE HEREBY DISCLAIMED AND EXCLUDED BY THE MANUFACTURER.

NOTE: Contact Giant Industries for Service School Information. Phone: (419)-531-4600



GIANT INDUSTRIES, INC., 900 N. Westwood Ave., P.O. Box 3187, Toledo, Ohio 43607
 PHONE (419) 531-4600, FAX (419) 531-6836, www.giantpumps.com
 © Copyright 2010 Giant Industries, Inc.