



P.O. Box 342, Delavan, WI 53115
 Phone: 1-800-365-6832
 Fax: 1-800-526-3757
 E-Mail: info@flotecwater.com
 Web Site: http://www.flotecwater.com

OWNER'S MANUAL
**Corrosion Resistant Centrifugal
 Lawn Sprinkler Pump**

NOTICE D'UTILISATION
**Pompe centrifuge et inoxydable
 pour l'arrosage du gazon**

MANUAL DEL USUARIO
**Bomba centrifuga resistente
 a la corrosion para rociadores
 de césped**

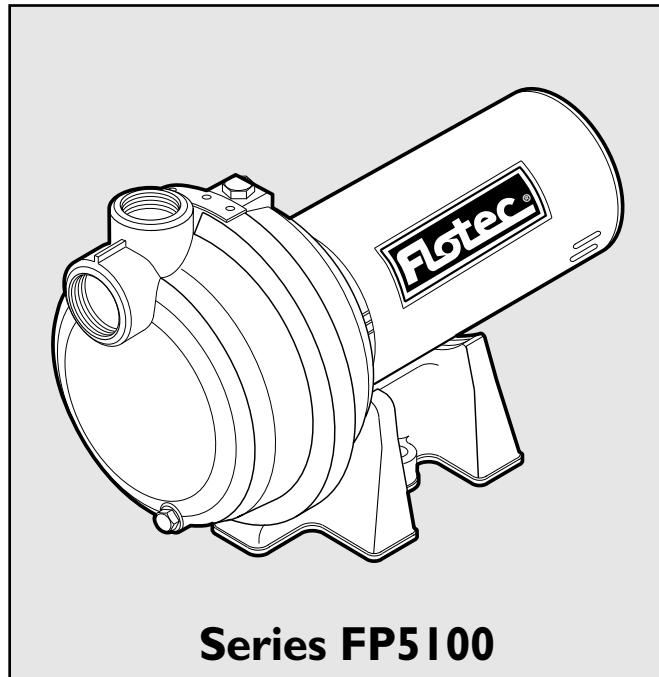

**Water
 is Our
 Business®**

Installation/Operation/Parts

*For further operating, installation,
 or maintenance assistance:*

Call 1-800-365-6832

English Pages 2-10

Installation/Fonctionnement/Pièces

*Pour plus de renseignements
 concernant l'utilisation,
 l'installation ou l'entretien,*

Composer le 1 (800) 365-6832

Français Pages 11-19

Instalación/Operación/Piezas

*Para mayor información sobre el
 funcionamiento, instalación o
 mantenimiento de la bomba:*

Llame al 1-800-365-6832

Español Paginas 20-28

READ AND FOLLOW SAFETY INSTRUCTIONS!

⚠ This is the safety alert symbol. When you see this symbol on your pump or in this manual, look for one of the following signal words and be alert to the potential for personal injury:

⚠ DANGER warns about hazards that **will** cause serious personal injury, death or major property damage if ignored.

⚠ WARNING warns about hazards that **can** cause serious personal injury, death or major property damage if ignored.

⚠ CAUTION warns about hazards that **will** or **can** cause minor personal injury or property damage if ignored.

The label **NOTICE** indicates special instructions which are important but not related to hazards.

Carefully read and follow all safety instructions in this manual and on pump.

Keep safety labels in good condition.

Replace missing or damaged safety labels.

Make workshops childproof; use padlocks and master switches; remove starter keys.

⚠ WARNING



Hazardous voltage. Can shock, burn, or cause death.

Ground pump before connecting to power supply. Disconnect power before working on pump, motor or tank.

⚠ Wire motor for correct voltage. See “Electrical” section of this manual and motor nameplate.

⚠ Ground motor before connecting to power supply.

⚠ Meet National Electrical Code, Canadian Electrical Code, and local codes for all wiring.

⚠ Follow wiring instructions in this manual when connecting motor to power lines.

ELECTRICAL SAFETY

⚠ WARNING Capacitor voltage may be hazardous. To discharge motor capacitor, hold insulated handle screwdriver **BY THE HANDLE** and short capacitor terminals together. Do not touch metal screwdriver blade or capacitor terminals. If in doubt, consult a qualified electrician.

GENERAL SAFETY

⚠ CAUTION Do not touch an operating motor. Modern motors are designed to operate at high temperatures. To avoid burns when servicing pump, allow it to cool for 20 minutes after shut-down before handling.

Pump is designed as a lawn sprinkler only. To avoid heat built-up, over pressure hazard and possible injury, do not use in a domestic water system. Do not use as a booster pump; pressurized suction may cause pump body to explode.

Do not allow pump or any system component to freeze. To do so will void warranty.

Pump water only with this pump.

Periodically inspect pump and system components.

Wear safety glasses at all times when working on pumps.

Keep work area clean, uncluttered and properly lighted; store properly all unused tools and equipment.

Keep visitors at a safe distance from the work areas.

“Dead Heading” a pump means running the pump while little or no water is released from the system.

Never run pump above recommended pressure shown on the performance chart.



⚠ WARNING

Hazardous pressure! Do not run pump against closed discharge.

Release all pressure on system before working on any component.

Thank you for purchasing a top quality, factory tested pump.

	Page
General Safety	2
Warranty	3
Installation	4,5
Electrical	6,7
Operation	8,9
Troubleshooting	9
Repair Parts	10

ATTACH ORIGINAL RECEIPT HERE FOR WARRANTY CONSIDERATION.

Flotec Limited Warranty

FLOTEC warrants to the original consumer purchaser ("Purchaser") of its products that they are free from defects in material or workmanship.

If within twelve (12) months from the date of the original consumer purchase any such product shall prove to be defective, it shall be repaired or replaced at FLOTEC's option, subject to the terms and conditions set forth below. Your original receipt of purchase is required to determine warranty eligibility.

Exceptions to the Twelve (12) Month Warranty

Ninety (90) Day Warranty:

If within ninety (90) days from original consumer purchase any Drill Pump, Pitcher Pump, or In-Line Water Filter Cartridge shall prove to be defective, it shall be replaced, subject to the terms set forth below.

Two (2) Year Warranty:

If within two (2) years from original consumer purchase any 1/3 HP Submersible Sump Pump or Model FP2800DCC shall prove to be defective, it shall be repaired or replaced at FLOTEC's option, subject to the terms and conditions set forth below.

Three (3) Year Warranty:

If within three (3) years from original consumer purchase any 4" Submersible Well Pump, or 1/2 HP Submersible Sump Pump, shall prove to be defective, it shall be repaired or replaced at FLOTEC's option, subject to the terms and conditions set forth below.

Five (5) Year Warranty:

If within five (5) years from original consumer purchase any Pre-Charge water system tank shall prove to be defective, it shall be repaired or replaced at FLOTEC's option, subject to the terms and conditions set forth below.

General Terms and Conditions

Purchaser must pay all labor and shipping charges necessary to replace product covered by this warranty. This warranty shall not apply to acts of God, nor shall it apply to products which, in the sole judgement of FLOTEC, have been subject to negligence, abuse, accident, misapplication, tampering, alteration; nor due to improper installation, operation, maintenance or storage; nor to other than normal application, use or service, including but not limited to, operational failures caused by corrosion, rust or other foreign materials in the system, or operation at pressures in excess of recommended maximums.

Requests for service under this warranty shall be made by returning the defective product to the Retail outlet or to FLOTEC as soon as possible after the discovery of any alleged defect. FLOTEC will subsequently take corrective action as promptly as reasonably possible. No requests for service under this warranty will be accepted if received more than 30 days after the term of the warranty.

This warranty sets forth FLOTEC's sole obligation and purchaser's exclusive remedy for defective products.

FLOTEC SHALL NOT BE LIABLE FOR ANY CONSEQUENTIAL, INCIDENTAL, OR CONTINGENT DAMAGES WHATSOEVER.

THE FOREGOING WARRANTIES ARE EXCLUSIVE AND IN LIEU OF ALL OTHER EXPRESS WARRANTIES. IMPLIED WARRANTIES, INCLUDING BUT NOT LIMITED TO THE IMPLIED WARRANTIES OF MERCHANTABILITY AND FITNESS FOR A PARTICULAR PURPOSE, SHALL NOT EXTEND BEYOND THE DURATION OF THE APPLICABLE EXPRESS WARRANTIES PROVIDED HEREIN.

Some states do not allow the exclusion or limitation of incidental or consequential damages or limitations on how long an implied warranty lasts, so the above limitations or exclusions may not apply to you. This warranty gives you specific legal rights and you may also have other rights which vary from state to state.

FLOTEC • P.O. Box 342 • Delavan, WI U.S.A. 53115

Phone: 1-800-365-6832 • Fax: 1-800-526-3757

E-Mail: info@flotecwater.com • Web Site: http://www.flotecwater.com

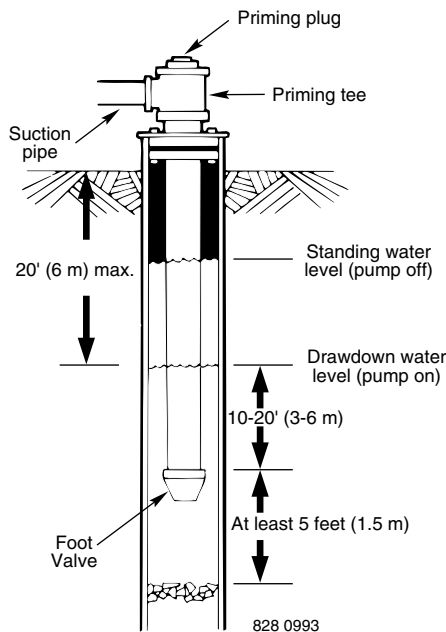

Figure 1: Cased/Dug Well Installation

BEFORE YOU INSTALL YOUR PUMP

NOTICE: Well must not be more than 20' (6.1 m) depth to water.

- Step 1. Long runs and many fittings increase friction and reduce flow. Locate pump as close to well as possible; use as few elbows and fittings as possible. Be sure suction line is straight and angles toward pump.
- Step 2. Be sure well and pipe are clear of sand, dirt and scale. Foreign matter will plug pump and void warranty. Use new pipe for best results.
- Step 3. Protect pump and all piping from freezing. Freezing will split pipe, damage pump and void warranty. Check locally for frost protection requirements (usually pipe must be 12" (30.5cm) below frost line and pump must be insulated).
- Step 4. Be sure all pipes and foot valve are clean and in good shape.
- Step 5. No air pockets in suction pipe.
- Step 6. No leaks in suction pipe. Use Teflon tape or Plasto-Joint Stik to seal pipe joints.
- Step 7. Unions installed near pump and well will aid in servicing. Leave room to use wrenches.

▲ WARNING Pump body may explode if used as booster pump. **DO NOT use in booster application.**

▲ CAUTION Motor normally operates at high temperature and will be too hot to touch. It is protected from heat damage during operation by an automatic internal cutoff switch. Before handling pump or motor, stop motor and allow it to cool for 20 minutes.

WELL PIPE INSTALLATION

NOTICE: Use installation method below which matches your well type.

CASED WELL/DUG WELL INSTALLATION

- Step 1. Inspect foot valve to be sure it works freely. Inspect strainer to be sure it is clean and secure.
- Step 2. Connect foot valve and strainer to first length of suction pipe and lower pipe into well. Add sections of pipe as needed, using Teflon tape on male threads (use 1-1/2" pipe for suction pipe). Be sure all suction pipe is leakproof or pump will lose prime and fail to pump. Install foot valve 10 to 20 ft. (3 to 6 m) below lowest level to which water will drop while pump is operating (pumping water level). Your well driller can furnish this information.
- Step 3. To prevent sand and sediment from entering pumping system, foot valve/strainer should be at least 5 ft. (1.5 m) above bottom of well.
- Step 4. When proper depth is reached, install sanitary well seal over pipe and in well casing. Tighten bolts to seal casing.
- Step 5. When using foot valve, a priming tee and plug are recommended. (Fig. 1).

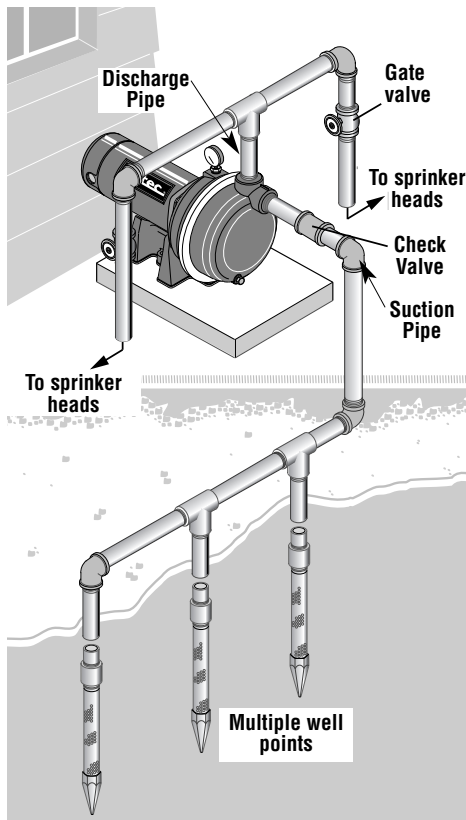

Figure 2: Driven Point Installation, Multiple Well Points

DRIVEN POINT INSTALLATION

- Step 1. Connect suction pipe to drive point (Fig. 2). Keep horizontal pipe run as short as possible. Use Teflon tape on male pipe threads. Multiple well points may be necessary to provide sufficient water to pump.
- Step 2. Install check valve in horizontal pipe. Flow arrow on check valve must point toward pump.

HORIZONTAL PIPING FROM WELL TO PUMP

- Step 1. Pump performance will be decreased if less than 1-1/2" pipe is used as suction pipe.
- Step 2. To aid priming on well point installations, install line check valve. Be sure check valve flow arrow points toward pump.

DISCHARGE PIPE SIZES

Discharge pipe size should be increased to reduce pressure losses caused by friction on long pipe runs.

- Up to 100' (30.5 m) run: Same size as pump discharge port.
- 100' - 300' (30.5 - 91.4 m) run: Increase one pipe size.
- 300' - 600' (91.4 - 182.9 m) run: Increase two pipe sizes.

LAWN SPRINKLING APPLICATION

This pump is designed for lawn sprinkling. Delivers plenty of water at full sprinkler pressure. Pumps from pond, cistern or well points.

Pump discharge can be divided to supply 4 or more sprinkler systems.

Do not use in booster pump applications.

PUMP/PIPING INSTALLATION

If turning pump on and off by pressure, a pressure switch and tank are required. For proper installation and operation instructions call Customer Service.

Use rigid pipe. Do not use hose or plastic tubing. See "Well Pipe Installation" for more information.

NOTICE: Use only Teflon tape or Teflon based joint compounds for making all threaded connections to the pump itself. **Do not use pipe joint compounds on plastic pumps:** they can react with the plastic in pump components. Make sure that all pipe joints in the suction pipe are air tight as well as water tight. *If the suction pipe can suck air, the pump will not be able to pull water from the well.*

- Step 1. Bolt pump to solid, level foundation.
- Step 2. Support all piping connected to pump.
- Step 3. Wrap 1-1/2 to 2 layers of Teflon tape clockwise (as you face end of pipe) on all male threads being attached to pump.
- Step 4. Tighten joints hand tight plus 1-1/2 turns. **Do not overtighten.**
- Step 5. Replace prime plug with pressure gauge. This will aid in sizing zones, troubleshooting, and following pump performance chart.

NOTICE: Install pump as close to well head as possible. Long piping runs and many fittings create friction and reduce flow.

NOTICE: For long horizontal pipe runs, install a priming tee between check valve and well head (Fig. 1). For driven point installations, install check valve. Be sure that check valve flow arrow points **toward** pump.

Connection diagram for dual voltage, single-phase motors. Your dual-voltage motor's terminal board (under the motor end cover) will match one of the diagrams below. Follow that diagram if necessary to convert motor to 115 Volt power.

Connect power supply wires to L1 and L2. For 3-phase motors, or if motor does not match these pictures, follow the connection diagram on the motor nameplate.

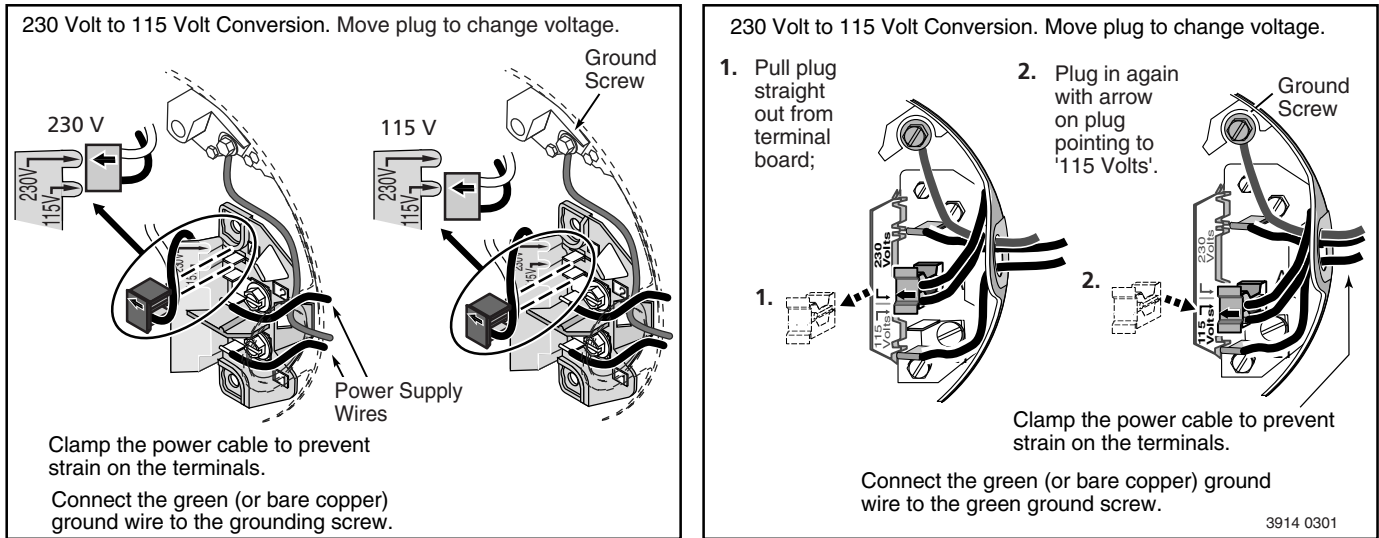

Figure 3 – 115/230V Dual Voltage Single Phase Wiring Diagram

⚠ WARNING

Hazardous voltage. Can shock, burn, or cause death. Disconnect power to motor before working on pump or motor. Ground motor before connecting to power supply.

WIRING

- ⚠ Ground motor before connecting to electrical power supply. Failure to ground motor can cause severe or fatal electrical shock hazard.**
- ⚠ Do not ground to a gas supply line.**
- ⚠ To avoid dangerous or fatal electrical shock, turn OFF power to motor before working on electrical connections.**
- ⚠ Supply voltage must be within $\pm 10\%$ of nameplate voltage. Incorrect voltage can cause fire or damage motor and voids warranty. If in doubt consult a licensed electrician.**
- ⚠ Use wire size specified in Wiring Chart (Page 7). If possible, connect pump to a separate branch circuit with no other appliances on it.**
- ⚠ Wire motor according to diagram on motor nameplate. If nameplate diagram differs from diagrams above, follow nameplate diagram.**

Step 1. Install, ground, wire and maintain this pump in accordance with electrical code requirements. Consult your local building inspector for information about codes.

- Step 2. Provide a correctly fused disconnect switch for protection while working on motor. Consult local or national electrical codes for switch requirements.
- Step 3. Disconnect power before servicing motor or pump. If the disconnect switch is out of sight of pump, lock it open and tag it to prevent unexpected power application.
- Step 4. Ground the pump permanently using a wire of the same size as that specified in wiring chart, below. Make ground connection to green grounding terminal under motor canopy marked GRD. or ⊕.
- Step 5. Connect ground wire to a grounded lead in the service panel or to a metal underground water pipe or well casing at least 10 feet long. Do not connect to plastic pipe or insulated fittings.
- Step 6. Protect current carrying and grounding conductors from cuts, grease, heat, oil, and chemicals.
- Step 7. Connect current carrying conductors to terminals L1 and L2 under motor canopy. When replacing motor, check wiring diagram on motor nameplate against Figure 3. If the motor wiring diagram does not match either diagram in Figure 3, follow the diagram on the motor.

IMPORTANT: 115/230 Volt single phase models are shipped from factory with motor wired for 230 volts. If power supply is 115 volts, remove motor canopy and reconnect motor as shown in Figure 3. Do not try to run motor as received on 115 volt current.

- Step 8. Motor has automatic internal thermal overload protection. If motor has stopped for unknown reasons, thermal overload may restart it unexpectedly, which could cause injury or property damage. Disconnect power before servicing motor.
- Step 9. If this procedure or the wiring diagrams are confusing, consult a licensed electrician.

Wiring Chart – Recommended Wire and Fuse Sizes for 115 and 230 volts

Pump Model	HP	Volts	Max. Load Amp	Branch Fuse Rating* Amp	AWG Min. Wire Size (mm ²)	DISTANCE IN FEET(METERS) FROM MOTOR TO SUPPLY				
						0 - 100 (0 - 30)	101 - 200 (31 - 61)	201 - 300 (62 - 91)	301 - 400 (92 - 122)	401 - 500 (123 - 152)
						AWG WIRE SIZE (mm ²)				
FP5192	3/4	115/230	14.8/7.4	20/15	12/14 (3/2)	12/14 (3/2)	8/14 (8.4/2)	6/14 (14/2)	6/12 (14/3)	4/10 (21/5.5)
FP5162	1	115/230	14.8/7.4	20/15	12/14 (3/2)	12/14 (3/2)	8/14 (8.4/2)	6/14 (14/2)	6/12 (14/3)	4/10 (21/5.5)
FP5172	1-1/2	115/230	19.2/9.6	25/15	10/14 (5.5/2)	10/14 (5.5/2)	8/14 (8.4/2)	6/12 (14/3)	4/10 (21/5.5)	4/10 (21/5.5)
FP5182	2	230	12.0	15	14 (2)	14 (2)	14 (2)	12 (3)	10 (5.5)	10 (5.5)
FP5182C	2	230	12.0	15	14 (2)	14 (2)	14 (2)	12 (3)	10 (5.5)	10 (5.5)

* Duel element or Fusetron time delay fuses recommended for all motor circuits.

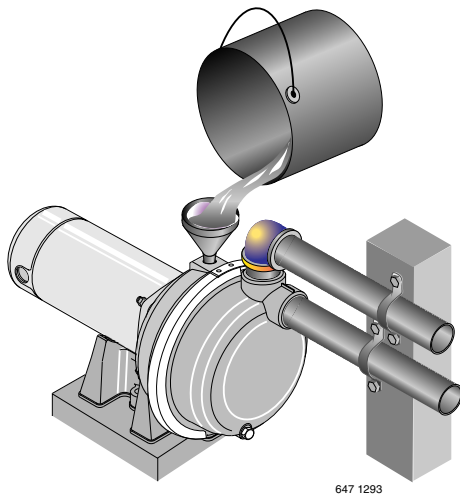

Figure 4: Fill Pump Before Starting

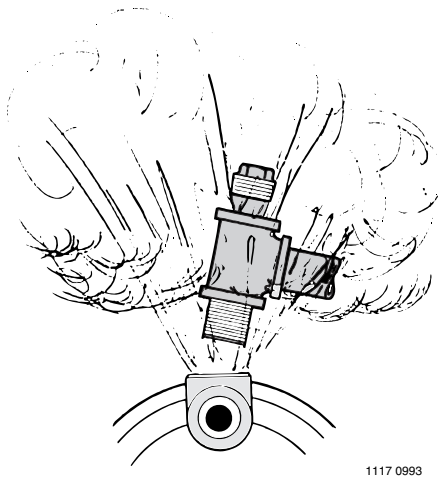

Figure 5: Do Not Run Pump With Outlet Shut Off

PRIMING THE PUMP

NOTICE: 'Priming' refers to pump expelling all air in the system and beginning to move water from its source out into system. It does not refer only to pouring water into pump (although pouring water in is usually the first step).

CAUTION NEVER run pump dry. Running pump without water may cause pump to overheat, damaging seal and possibly causing burns to persons handling pump. Fill pump with water before starting.

- Step 1. Remove priming plug.
- Step 2. Make sure suction and discharge valves and any hoses on discharge side of pump are open.
- Step 3. Fill pump and suction pipe with water (Fig. 4).
- Step 4. Replace priming plug, using Teflon tape on thread; tighten plug.

NOTICE: If priming tee and plug have been provided for long horizontal run, be sure to fill suction pipe through this tee and replace plug. (Use Teflon tape on plug.)

- Step 5. Start pump; water should be produced in 10 minutes or less, time depends on depth to water (not more than 20' (6 m)) and length of horizontal run (10' (3 m) of horizontal suction pipe = 1' (30.5 cm) of vertical lift due to friction losses in pipe). If no water is produced within 10 minutes, stop pump, release all pressure, remove priming plug, refill and try again.

WARNING NEVER run pump against closed discharge. To do so can boil water inside pump, causing hazardous pressure in unit, risk of explosion and possibly scalding persons handling pump (Fig. 5). Replace priming plug with pressure gauge to monitor pressure so that it is not allowed to exceed maximum pumping pressures according to performance chart.

NOTICE: Open water system faucets before priming pump for the first time.

- Remove priming plug.
- Step A. Fully open control valve (turn counterclockwise).
- Step B. Fill pump and suction pipe with water.
- Step C. Replace priming plug, using Teflon tape on plug thread; tighten plug.

To prevent explosion, do the following:

- Step A. Be sure discharge (valve, pistol grip hose nozzle, etc.) is open whenever pump is running.
- Step B. If pump fails to produce water when attempting to prime, release all pressure, drain pump and refill with cold water after every attempt.
- Step C. When priming, monitor pump body and piping temperature. Motor will warm up; this is normal. If pump body or piping begin to feel warm to touch, shut off pump and allow system to cool. Release all pressure in system and refill pump and piping with cold water.

Step D. Make sure discharge pipe and zone size are not too small for this pumps performance.

Performance Chart / GPM(LPM)

Discharge Pressure PSI (kPa)	FP5192 – 3/4 HP				FP5162 – 1 HP				FP5172 – 1-1/2 HP				FP5182, FP5182C – 2 HP			
	Height Of Pump Above Water / Feet (Meter)															
	5'(1.5)	10'(3)	15'(4.6)	20'(6.1)	5'(1.5)	10'(3)	15'(4.6)	20'(6.1)	5'(1.5)	10'(3)	15'(4.6)	20'(6.1)	5'(1.5)	10'(3)	15'(4.6)	20'(6.1)
10 (69)	49(185)	44(166)	43(163)	40(151)	55(208)	49(185)	48(181)	45(170)	67(254)	61(231)	56(212)	46(174)	69(261)	64(242)	65(246)	62(235)
15 (103)	46(174)	41(155)	40(151)	39(147)	51(193)	46(174)	45(170)	44(166)	66(250)	58(220)	55(208)	45(170)	65(246)	62(235)	60(227)	57(215)
20 (138)	40(151)	38(144)	35(132)	33(125)	45(170)	42(159)	39(148)	37(140)	61(231)	56(212)	54(204)	44(166)	59(223)	56(212)	54(204)	52(197)
25 (172)	34(129)	31(117)	29(110)	26(98)	38(144)	35(132)	32(121)	29(110)	55(208)	52(197)	51(193)	43(163)	52(197)	50(189)	48(181)	46(174)
30 (207)	28(106)	25(95)	22(83)	18(68)	31(117)	28(106)	24(90)	20(76)	48(181)	45(170)	44(166)	37(140)	47(178)	45(170)	42(159)	40(151)
35 (241)	21(79)	17(64)	14(53)	10(38)	23(87)	19(72)	16(60)	11(42)	39(147)	37(140)	34(129)	28(106)	42(159)	38(144)	35(132)	32(121)
40 (276)	15(57)	12(45)	7(26)		17(64)	13(49)	8(30)		33(125)	27(102)	20(76)	11(42)	34(129)	30(113)	27(102)	23(87)
45 (310)									18(68)	14(53)	8(30)		25(95)	18(68)	13(49)	10(38)
50 (345)													14(53)	7(26)		

All models except FP5182 have discharge and suction size of 1-1/2" NPT. FP5182 has 2" NPT suction and discharge.

Troubleshooting

⚠ WARNING Capacitor voltage may be hazardous. To discharge capacitor, hold insulated handle screwdriver BY THE HANDLE and short capacitor terminals together. Do not touch metal screwdriver blade or capacitor terminals. If in doubt, consult a qualified electrician.

SYMPTOM	POSSIBLE CAUSE(S)	CORRECTIVE ACTION
Motor will not run	Disconnect switch is off Fuse is blown or circuit breaker tripped Starting switch is defective Wires at motor are loose, disconnected, or wired incorrectly	Be sure switch is on. Replace fuse or reset circuit breaker. DISCONNECT POWER; Replace starting switch. Refer to instructions on wiring (Page 7). DISCONNECT POWER; check and tighten all wiring.
Motor runs hot and overload kicks off or motor does not run and only hums	Motor is wired incorrectly Voltage is too low	Refer to instructions on wiring. Check voltage being supplied to motor. Install heavier wiring if wire size is too small (See Electrical / Wiring Chart).
Motor runs but no water is delivered* * (Note: Stop pump; then check prime before looking for other causes. Unscrew priming plug and see if water is in priming hole).	Pump in new installation did not pick up prime through: 1. Improper priming 2. Air leaks 3. Leaking foot valve or check valve 4. Pipe size too small Pump has lost prime through: 1. Air leaks 2. Water level below suction pipe inlet Impeller is plugged Check valve or foot valve is stuck shut Pipes are frozen Foot valve and/or strainer are buried in sand or mud	In new installation: 1. Re-prime according to instructions. 2. Check all connections on suction line, with soapy water or shaving cream. 3. Replace foot valve or check valve. 4. Re-pipe using size of suction and discharge ports on pump. In installation already in use: 1. Check all connections on suction line and shaft seal with soapy water. 2. Lower suction line into water and re-prime. If receding water level in well exceeds 25' (7.6M), a deep well pump is needed. Clean impeller. Replace check valve or foot valve. Thaw pipes. Bury pipes below frost line. Heat pit or pump house. Raise foot valve and/or strainer above bottom of water source. Clean foot valve and strainer.
*Pump does not deliver water to full capacity	Water level in well is lower than estimated Steel piping (if used) is corroded or limed, causing excess friction Piping is too small in size Pump not being supplied with enough water	A deep well jet will be needed if your well is more than 25' (7.6M) depth to water. Replace with plastic pipe where possible, otherwise with new steel pipe. Re-pipe using size of suction and discharge ports on pump. Add additional well points.
Pump leaks around clamp	Clamp loose	STOP PUMP, tighten clamp nut 1-2 turns. Alternately tighten and tap on clamp with mallet to seat O-Ring. Do not overtighten.

For parts or assistance, call Flotec Customer Service at 1-800-365-6832

Models
 FP5192-08
 FP5162-08
 FP5172-08
 FP5182-08
 FP5182-08C

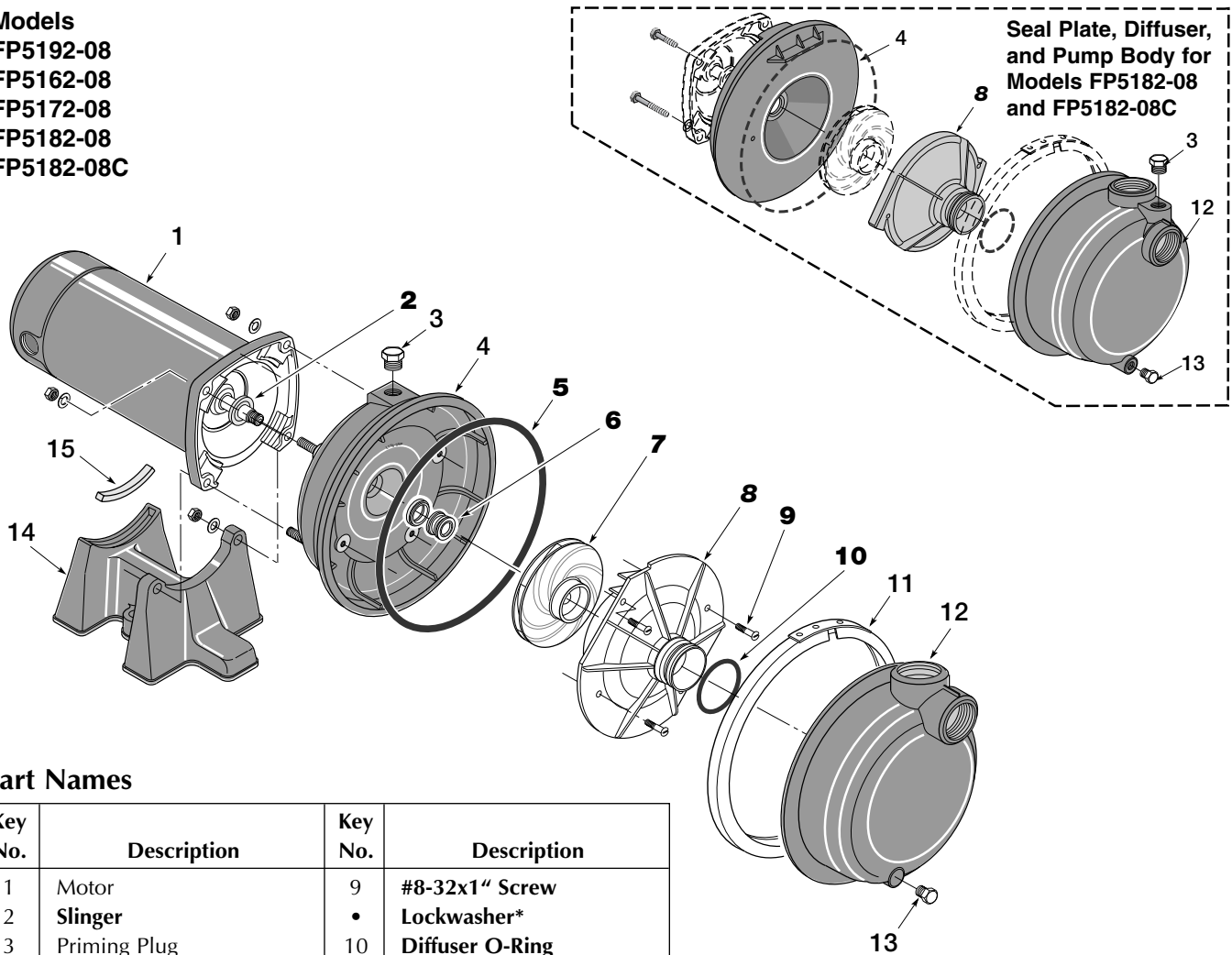

Part Names

Key No.	Description	Key No.	Description
1	Motor	9	#8-32x1" Screw
2	Slinger		• Lockwasher*
3	Priming Plug	10	Diffuser O-Ring
4	Seal Plate	11	Clamp
5	O-Ring	12	Pump Body
6	Shaft Seal	13	Drain Plug
7	Impeller	14	Base
8	Diffuser	15	Motor Pad

*Models FP5182-08 and FP5182-08C only.

Parts in **Bold Face** are included in Seal and Gasket Kit and in Overhaul Kit.

Parts in **Bold Face Italics** are included in Overhaul Kit only.

Key No.	Part Description	FP5192-08 3/4 HP	FP5162-08 1 HP	FP5172-08 FP5172-08C 1-1/2 HP	FP5182-08 FP5182-08C 2 HP
		115V/230V 60 Hz/1 Ph			230V 60 Hz/1 Ph
1	Motor	A100DHL	A100ELL	A100FLL	A100GLL
4	Seal Plate Complete	L176-47P1	L176-47P1	L176-47P1	C103-189P
11	"V" Clamp	C19-54SS	C19-54SS	C19-54SS	C19-37A
12	Pump Body Front Half	C176-53P	C176-53P	C176-53P	C176-62P
14	Base	C4-42P	C4-42P	C4-42P	C4-42P
	• Seal and Gasket Kit	FPP5000	FPP5000	FPP5000	FPP50000
	• Includes Items 2, 5, 6, 9, & 10. See "Part Names," above.				
	• Includes all items in Seal and Gasket Kit plus Item 7, impeller , and 8, diffuser . See "Part Names," above.	FPP5007	FPP5001	FPP5002	FPP5008

For parts or assistance, call Flotec Customer Service at 1-800-365-6832