



P.O. Box 342, Delavan, WI 53115
 Phone: 1-800-365-6832
 Fax: 1-800-526-3757
 E-Mail: info@flotecwater.com
 Web Site: http://www.flotecwater.com

Water
 is Our
Business

OWNER'S MANUAL

**Shallow Well Jet Pumps/
 Tank Systems**

NOTICE D'UTILISATION

**Systems de pompes enfante
 montées sur réservoir pour
 puisage en eau peu profonde**

MANUAL DEL USUARIO

**Sistemas de bombas tip "jet"/
 tanques para pozos poco profundos**

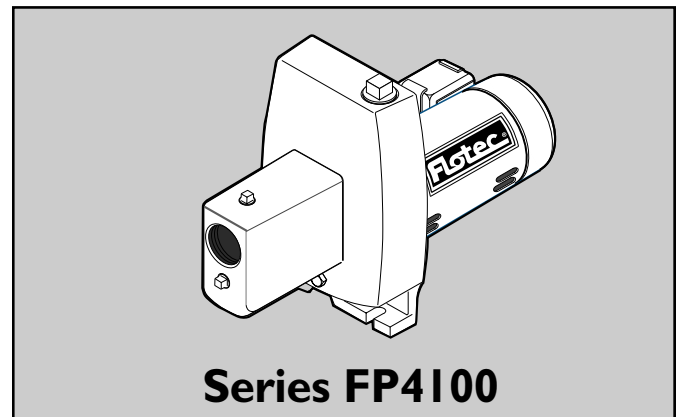
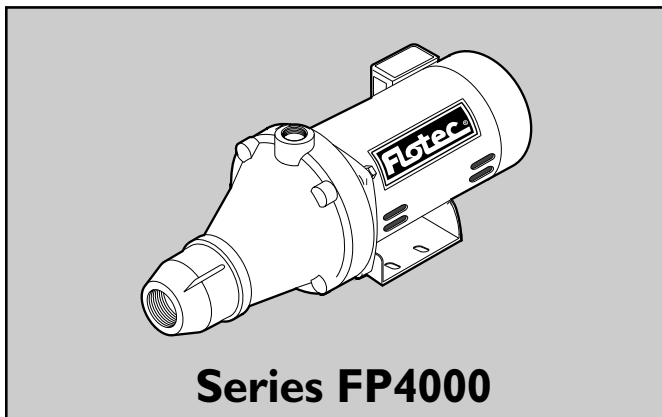
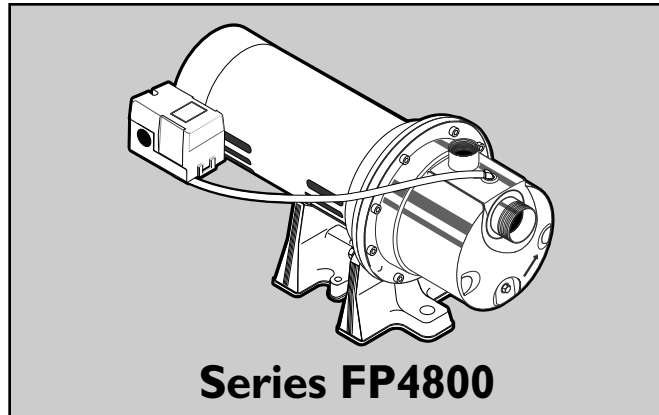

Installation/Operation/Parts

*For further operating, installation,
 or maintenance assistance:*

Call 1-800-365-6832

English Pages 2-13

Installation/Fonctionnement/Pièces

*Pour plus de renseignements
 concernant l'utilisation,
 l'installation ou l'entretien,*

Composer le 1 (800) 365-6832

Français Pages 14-25

Instalación/Operación/Piezas

*Para mayor información sobre el
 funcionamiento, instalación o
 mantenimiento de la bomba:*

Llame al 1-800-365-6832

Español Paginas 26-36

READ AND FOLLOW SAFETY INSTRUCTIONS!

⚠ This is the safety alert symbol. When you see this symbol on your pump or in this manual, look for one of the following signal words and be alert to the potential for personal injury:

⚠ DANGER warns about hazards that **will** cause serious personal injury, death or major property damage if ignored.

⚠ WARNING warns about hazards that **can** cause serious personal injury, death or major property damage if ignored.

⚠ CAUTION warns about hazards that **will** or **can** cause minor personal injury or property damage if ignored.

The label **NOTICE** indicates special instructions which are important but not related to hazards.

Carefully read and follow all safety instructions in this manual and on pump.

Keep safety labels in good condition.
Replace missing or damaged safety labels.

ELECTRICAL SAFETY

⚠ WARNING Capacitor voltage may be hazardous. To discharge motor capacitor, hold insulated handle screwdriver **BY THE HANDLE** and short capacitor terminals together. Do not touch metal screwdriver blade or capacitor terminals. If in doubt, consult a qualified electrician.

GENERAL SAFETY

⚠ CAUTION Do not touch an operating motor. Modern motors are designed to operate at high temperatures. To avoid burns when servicing pump, allow it to cool for 20 minutes after shut-down before handling.

Do not allow pump or any system component to freeze. To do so will void warranty.

Pump water only with this pump.

Periodically inspect pump and system components.

Wear safety glasses at all times when working on pumps.

Keep work area clean, uncluttered and properly lighted; store properly all unused tools and equipment.

Keep visitors at a safe distance from the work areas.

⚠ WARNING Pump body may explode if used as a booster pump unless relief valve capable of passing full pump flow at 75 psi is installed.

<p>⚠ WARNING</p> 
<p>Hazardous voltage. Can shock, burn, or cause death.</p> <p>Ground pump before connecting to power supply. Disconnect power before working on pump, motor or tank.</p>

- ⚠** Wire motor for correct voltage. See “Electrical” section of this manual and motor nameplate.
- ⚠** Ground motor before connecting to power supply.
- ⚠** Meet National Electrical Code, Canadian Electrical Code, and local codes for all wiring.
- ⚠** Follow wiring instructions in this manual when connecting motor to power lines.

	<p>⚠ WARNING</p> <p>Hazardous pressure! Install pressure relief valve in discharge pipe.</p> <p>Release all pressure on system before working on any component.</p>
--	---

Thank you for purchasing a top quality, factory tested pump.

	Page
General Safety	2
Warranty	3
Installation	4,5
Connecting Discharge Piping.....	6
Electrical	7,8
Preparing To Start The Pump.....	9
Repair Parts	10-12
Troubleshooting.....	13

ATTACH ORIGINAL RECEIPT HERE FOR WARRANTY CONSIDERATION.

Flotec Limited Warranty

FLOTEC warrants to the original consumer purchaser ("Purchaser") of its products that they are free from defects in material or workmanship.

If within twelve (12) months from the date of the original consumer purchase any such product shall prove to be defective, it shall be repaired or replaced at FLOTEC's option, subject to the terms and conditions set forth below. Your original receipt of purchase is required to determine warranty eligibility.

Exceptions to the Twelve (12) Month Warranty

Ninety (90) Day Warranty:

If within ninety (90) days from original consumer purchase any Drill Pump, Pitcher Pump, or In-Line Water Filter Cartridge shall prove to be defective, it shall be replaced, subject to the terms set forth below.

Two (2) Year Warranty:

If within two (2) years from original consumer purchase any 1/3 HP Submersible Sump Pump or Model FP2800DCC shall prove to be defective, it shall be repaired or replaced at FLOTEC's option, subject to the terms and conditions set forth below.

Three (3) Year Warranty:

If within three (3) years from original consumer purchase any 4" Submersible Well Pump, or 1/2 HP Submersible Sump Pump, shall prove to be defective, it shall be repaired or replaced at FLOTEC's option, subject to the terms and conditions set forth below.

Five (5) Year Warranty:

If within five (5) years from original consumer purchase any Pre-Charge water system tank shall prove to be defective, it shall be repaired or replaced at FLOTEC's option, subject to the terms and conditions set forth below.

General Terms and Conditions

Purchaser must pay all labor and shipping charges necessary to replace product covered by this warranty. This warranty shall not apply to acts of God, nor shall it apply to products which, in the sole judgement of FLOTEC, have been subject to negligence, abuse, accident, misapplication, tampering, alteration; nor due to improper installation, operation, maintenance or storage; nor to other than normal application, use or service, including but not limited to, operational failures caused by corrosion, rust or other foreign materials in the system, or operation at pressures in excess of recommended maximums.

Requests for service under this warranty shall be made by returning the defective product to the Retail outlet or to FLOTEC as soon as possible after the discovery of any alleged defect. FLOTEC will subsequently take corrective action as promptly as reasonably possible. No requests for service under this warranty will be accepted if received more than 30 days after the term of the warranty.

This warranty sets forth FLOTEC's sole obligation and purchaser's exclusive remedy for defective products.

FLOTEC SHALL NOT BE LIABLE FOR ANY CONSEQUENTIAL, INCIDENTAL, OR CONTINGENT DAMAGES WHATSOEVER.

THE FOREGOING WARRANTIES ARE EXCLUSIVE AND IN LIEU OF ALL OTHER EXPRESS WARRANTIES. IMPLIED WARRANTIES, INCLUDING BUT NOT LIMITED TO THE IMPLIED WARRANTIES OF MERCHANTABILITY AND FITNESS FOR A PARTICULAR PURPOSE, SHALL NOT EXTEND BEYOND THE DURATION OF THE APPLICABLE EXPRESS WARRANTIES PROVIDED HEREIN.

Some states do not allow the exclusion or limitation of incidental or consequential damages or limitations on how long an implied warranty lasts, so the above limitations or exclusions may not apply to you. This warranty gives you specific legal rights and you may also have other rights which vary from state to state.

FLOTEC • P.O. Box 342 • Delavan, WI U.S.A. 53115

Phone: 1-800-365-6832 • Fax: 1-800-526-3757

E-Mail: info@flotecwater.com • Web Site: <http://www.flotecwater.com>

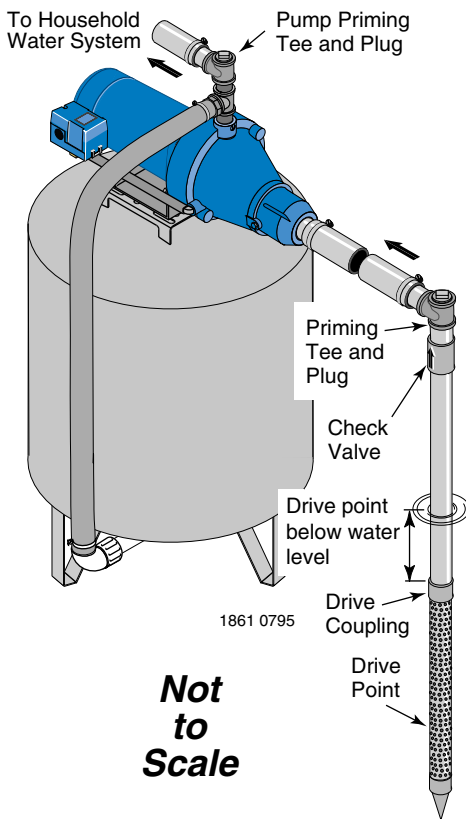

Figure 1: Driven Point Installation

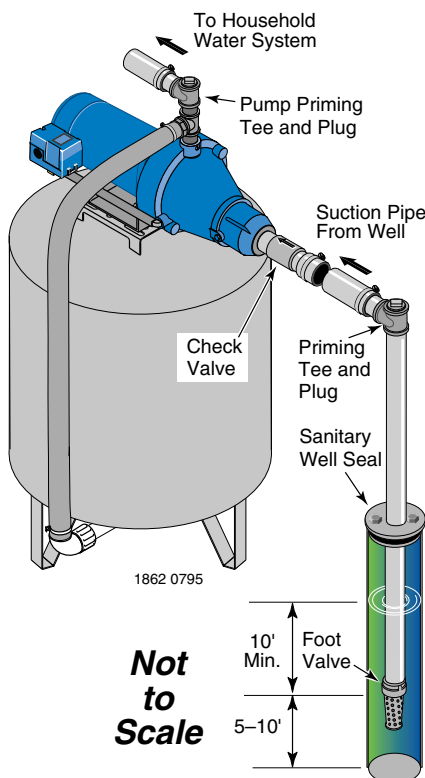

Figure 2: Cased Well Installation

REPLACING AN OLD PUMP

⚠ WARNING Hazardous voltage. Disconnect power to pump before working on pump or motor.

- Step 1. Drain and remove the old pump. Check the old pipe for scale, lime, rust, etc., and replace it if necessary.
- Step 2. Install the pump in the system. Make sure that all pipe joints in the suction pipe are air-tight as well as water tight. *If the suction pipe can suck air, the pump will not be able to pull water from the well.*
- Step 3. Adjust the pump mounting height so that the plumbing connections do not put a strain on the pump body. Support the pipe so that the pump body does not take the weight of piping or fittings.

You have just completed the well plumbing for your new shallow well jet pump. Please go to Page 6 for discharge pipe and tank connections.

WELL POINT (DRIVEN POINT) INSTALLATION (Figure 1)

- Step 1. Drive the well, using “drive couplings” and a “drive cap”. “Drive fittings” are threaded all the way through and allow the pipe ends to butt against each other so that the driving force of the maul is carried by the pipe and *not* by the threads. The ordinary fittings found in hardware stores are not threaded all the way through the fitting and can collapse under impact. “Drive fittings” are also smoother than standard plumbing fittings, making ground penetration easier.
- Step 2. Mount the pump as close to the well as possible

- Step 3. Use the fewest possible fittings (especially elbows) when connecting the pipe from the well point to the pump suction port. The suction pipe should be at least as large as the suction port on the pump (include a check valve if your pump is not equipped with one – see Figure 1). Support the pipe so that there are no dips or sags in the pipe, so it doesn’t strain the pump body, and so that it slopes slightly upward from the well to the pump (high spots can cause air pockets which can air lock the pump). Seal the suction pipe joints with teflon tape or a teflon based pipe joint compound. Joints must be air- and water-tight. *If the suction pipe can suck air, the pump cannot pull water from the well.* If one well point does not supply enough water, consider connecting two or three well points to one suction pipe.

You have just completed the suction piping for your new shallow well jet pump. Please go to Page 6 for discharge pipe and tank connections

CASED WELL INSTALLATION, 2” OR LARGER CASING (Figure 2)

- Step 1. Mount the pump as close to the well as possible.
- Step 2. Assemble the foot valve, strainer, and well pipe (see Figure 2). Make sure that the foot valve works freely.
- Step 3. Lower the pipe into the well until the strainer is five feet above the bottom of the well. It should also be at least 10 feet below the well’s water level *while the pump is running* in order to prevent the pump from sucking air. Install a sanitary well seal.

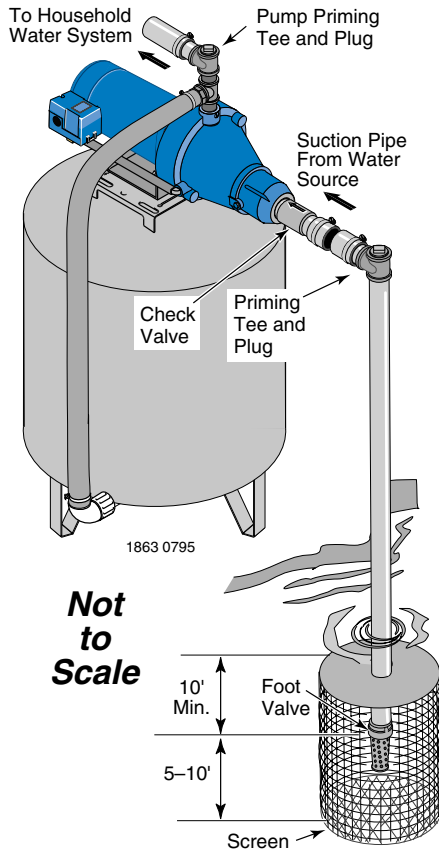

Figure 3: Surface Water Installation

Step 4. Install a priming tee, priming plug, and suction pipe to the pump (see Figure 2). Connect the pipe from the well to the pump suction port, using the fewest possible fittings – especially elbows – as fittings increase friction in the pipe (however, include a foot valve – see Figure 2). The suction pipe should be at least as large as the suction port on the pump. Use teflon tape or a teflon-based pipe joint compound on threaded pipe joints. Support the pipe so that there are no dips or sags in the pipe, so it doesn't strain the pump body, and so that it slopes slightly upward from the well to the pump (high spots can cause air pockets which can air lock the pump). Seal the suction pipe joints with teflon tape or a teflon based pipe joint compound. Joints must be air- and water-tight. *If the suction pipe can suck air, the pump cannot pull water from the well.*

You have just completed the suction piping for your new shallow well jet pump. Please go to Page 6 for discharge pipe and tank connections.

INSTALLATION FOR SURFACE WATER (Figure 3)

- Step 1. The pump should be installed as close to the water as possible, with the fewest possible fittings (especially elbows) in the suction pipe. The suction pipe should be at least as large as the suction port on the pump.
- Step 2. Assemble a foot valve and suction pipe (see Figure 3). Make sure that the foot valve works freely. Use teflon tape or a teflon-based pipe joint compound on threaded pipe joints. Protect the foot valve assembly from fish, trash, etc, by installing a screen around it (see Figure 3).
- Step 3. Lower the pipe into the water until the strainer is five feet above the bottom. It should also be at least 10 feet below the water level in order to prevent the pump from sucking air.
- Step 4. Install a priming tee, priming plug, and suction pipe to the pump (see Figure 3). Support the pipe so that there are no dips or sags in the pipe, so it doesn't strain the pump body, and so that it slopes slightly upward from the well to the pump (high spots can cause air pockets which can air lock the pump). Seal the suction pipe joints with teflon tape or a teflon based pipe joint compound. Joints must be air- and water-tight. *If the suction pipe can suck air, the pump cannot pull water from the well.*

You have just completed the plumbing for your new shallow well jet pump. Please go to Page 6 for discharge pipe and tank connections.

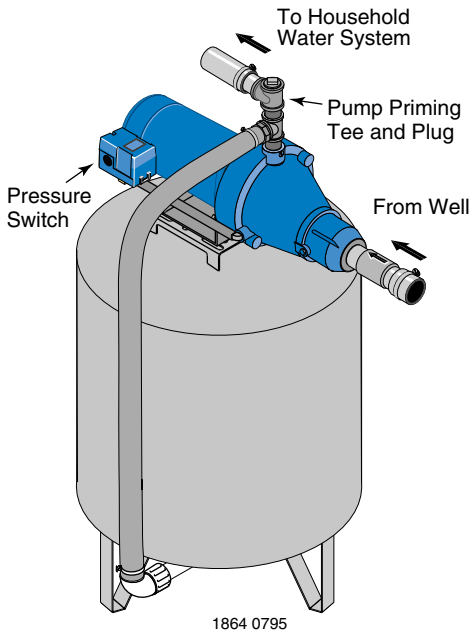

Figure 4: Pre-charged Tank Connections

PRE-CHARGE TANK CONNECTION (Figure 4)

- Step 1. Install two tees in the pump discharge port (see Figure 4). The pipe size must be at least as large as the discharge port.
- Step 2. Run a pipe or reinforced hose from one arm of the first tee to the port on the pre-charged tank.
- Step 3. Connect the other end of the discharge tee to your plumbing system.
- Step 4. Check the pre-charge of air in the tank with an ordinary tire gauge. The pre-charge should be 2 PSI less than the cut-in setting of the pump's pressure switch. The pre-charge is measured *when there is no water pressure in the tank*. Your new pump has a 30/50 PSI switch, so adjust the tank pre-charge pressure to 28 PSI.

Congratulations! You have just completed the tank connection for your jet pump.

Please go to Pages 7 and 8 for electrical hookup.

STANDARD TANK CONNECTION (Figure 5)

- Step 1. Install one tee in the pump discharge port (see Figure 5).
- Step 2. Run a pipe from the pump discharge port to the inlet port of your tank. The pipe size must be at least as large as the discharge port.
- Step 3. Remove the 1/8" NPT pipe plug from the pump Air Volume Control (AVC) port (see Figure 5). Run tubing from the pump's AVC port (see Figure 5) to the port on the AVC mounted on the tank. See instructions provided with tank and AVC for details. AVC port location will vary, depending on your pump model (see exploded views, Page 10).

Congratulations! You have just completed the tank connection for your jet pump.

Please go to Pages 7 and 8 for electrical hookup.

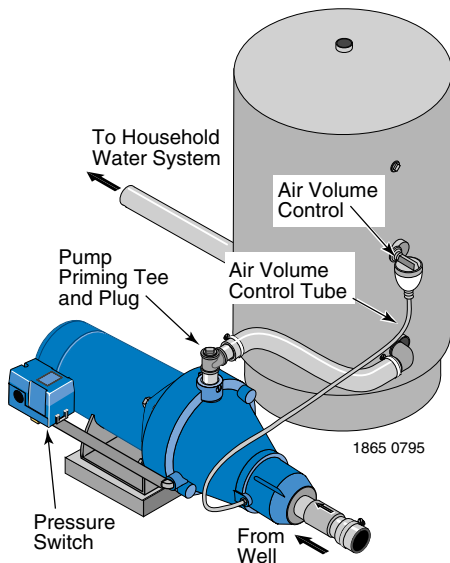

Figure 5: Standard Tank Connections

Sealing Pipe Joints

Use only Teflon tape or Teflon based joint compounds for making all threaded connections to the pump itself. **Do not use pipe joint compounds on plastic pumps:** they can react with the plastic in pump components. Make sure that all pipe joints in the suction pipe are air tight as well as water tight. *If the suction pipe can suck air, the pump will not be able to pull water from the well.*

⚠ Disconnect power before working on pump, motor, pressure switch, or wiring.

MOTOR SWITCH SETTINGS

NOTE: 1/2 HP motors are wired for 115 volts only, and have no motor wiring to change.

3/4 HP or 1 HP motor terminal boards (located under the motor end cover) should look like one of those below.

If the motor can operate at either 115 or 230 volts, it is set at the factory to 230 volts. Do not change motor wiring if line voltage is 230 volts, or if you have a single voltage motor.

⚠ CAUTION Never wire a 115 volt motor to a 230 volt line.

Plug Type Voltage Selector

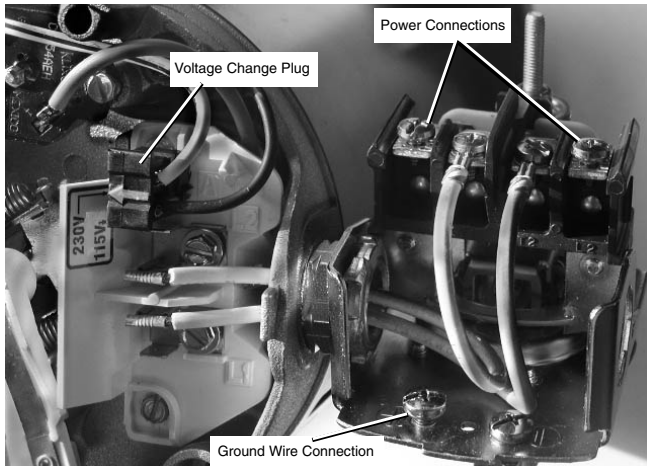

Figure 12: Voltage set to 230 volts, Plug Type

Voltage is factory set to 230 volts. To change to 115 volts:

1. Make sure power is off.
2. Pull the voltage change plug off of the tabs.
3. Move the voltage change plug to the 115 volt position. The plug will now cover 2 metal tabs and the arrow on the plug will line up with the 115V arrow on the label (see Figure 13).



Figure 13: Voltage set to 115 volts, Plug Type

4. Attach the incoming power leads to the two outer screws on the pressure switch as shown in Figure 12.
5. Attach the ground wire to one of the grounding connections, shown in Figure 12.
6. If there are other wires, they should be capped.
7. Reinstall the Motor end cover.

Dial Type Voltage Selector

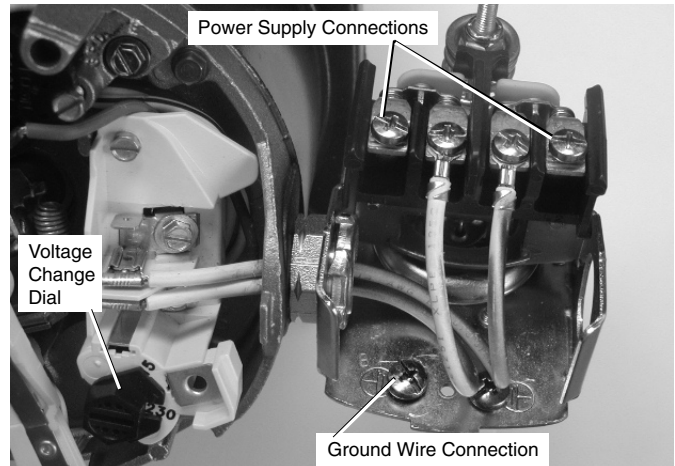

Figure 14: Voltage set to 230 volts, Dial Type

Voltage is factory set to 230 volts. To change to 115 volts:

1. Make sure power is off.
2. Turn the dial counter-clockwise until 115 shows in the dial window as shown in Figure 15.

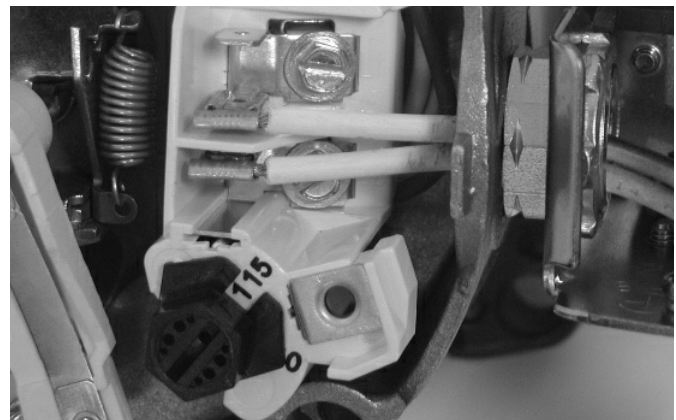

Figure 15: Voltage set to 115 volts, Dial Type

3. Attach the incoming power leads to the two outer screws on the pressure switch as shown in Figure 14.
4. Attach the ground wire to the grounding connections as shown in Figure 14.
5. If there are other wires, they should be capped.
6. Reinstall the Motor end cover.

⚠ WARNING Hazardous voltage. Can shock, burn, or kill. Connect ground wire before connecting power supply wires. Use the wire size (including the ground wire) specified in the wiring chart. If possible, connect the pump to a separate branch circuit with no other appliances on it.

⚠ WARNING Explosion hazard. Do not ground to a gas supply line.

WIRING CONNECTIONS

⚠ WARNING Fire hazard. Incorrect voltage can cause a fire or seriously damage the motor and voids the warranty. The supply voltage must be within ±10% of the motor nameplate voltage.

NOTICE: Dual-voltage motors are factory wired for 230 volts. If necessary, reconnect the motor for 115 volts, as shown. Do not alter the wiring in single voltage motors.

Install, ground, wire, and maintain your pump in compliance with the National Electrical Code (NEC) or the Canadian Electrical Code (CEC), as applicable, and with all local codes and ordinances that apply. Consult your local building inspector for code information.

Connection Procedure:

- Step 1. Connect the ground wire first as shown in Figure 6. The ground wire must be a solid copper wire at least as large as the power supply wires.
- Step 2. There must be a solid metal connection between the pressure switch and the motor for motor grounding protection. If the pressure switch is not connected to the motor, connect the green ground screw in the switch to the green ground screw under the motor end cover. Use a solid copper wire at least as large as the power supply wires.
- Step 3. Connect the ground wire to a grounded lead in a service panel, to a metal underground water pipe, to a metal well casing at least ten feet (3M) long, or to a ground electrode provided by the power company or the hydro authority.
- Step 4. Connect the power supply wires to the pressure switch as shown in Figure 6.

You have just completed the wiring for your pump.

Please go to Page 9 for startup preparations.

Wiring Chart – Recommended Wire and Fuse Sizes

Motor HP	Volts	Max. Load Amp	Branch Fuse Rating Amp	DISTANCE IN FEET(METERS) FROM MOTOR TO SUPPLY				
				0 - 100 (0 - 30)	101 - 200 (31 - 61)	201 - 300 (62 - 91)	301 - 400 (92 - 122)	401 - 500 (123 - 152)
				AWG WIRE SIZE (mm ²)				
1/2	115	9.4	15	14 (2)	10 (5.5)	10 (5.5)	6 (14)	6 (14)
3/4	115/230	12.2/6.1	20/15	12/14 (3/2)	10/14 (5.5/2)	8/14 (8.4/2)	6/12 (14/3)	6/12 (14/3)
3/4 (4822)	115/230	14.8/7.4	20/15	12/14 (3/2)	8/14 (8.4/2)	6/14 (14/2)	6/12 (4/3)	4/10 (21/5.5)
1 (4832)	115/230	19.2/9.6	25/15	10/14 (5.5/2)	8/14 (8.4/2)	6/12 (14/3)	4/10 (21/5.5)	4/10 (21/5.5)

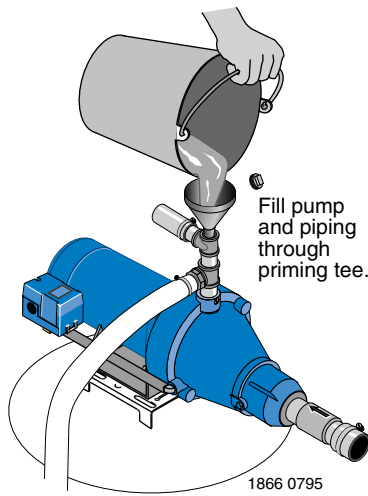

Figure 7: Prime the Pump

PRIMING

▲ WARNING Never run pump against closed discharge. To do so can boil water inside pump, causing hazardous pressure in unit, risk of explosion and possibly scalding persons handling pump.

▲ CAUTION Never run pump dry. Running pump without water may cause pump to overheat, damaging seal and possibly causing burns to persons handling pump. Fill pump with water before starting.

- Step 1. Remove the priming plug from the pump and fill the pump, fill all piping between the pump and the well, and make sure that all piping in the well is full. If you have also installed a priming tee in the suction piping, remove the plug from the tee and fill the suction piping.
- Step 2. Replace all fill plugs.
- Step 3. **Power on!** Start the pump. If you don't have water after 2 or 3 minutes, stop the pump and remove the fill plugs. Refill the pump and piping. You may have to repeat this several times in order to get all the trapped air out of the piping. A pump lifting water 25' may take as long as 15 minutes to prime.
- Step 4. After the pump has built up pressure in the system and shut off, check the pressure switch operation by opening a faucet or two and running enough water out to bleed off pressure until the pump starts. The pump should start when pressure drops to 30 PSI and stop when pressure reaches 50 PSI. Run the pump through one or two complete cycles to verify correct operation. This will also help clean the system of dirt and scale dislodged during installation.

Congratulations on a successful installation.

If you were unsuccessful, please refer to the Troubleshooting section (Page 10) or call our customer service technical staff.

Thank you for purchasing Flotec Products.

FP4012-08, FP4012-08C
FP4022-08, FP4022-08C

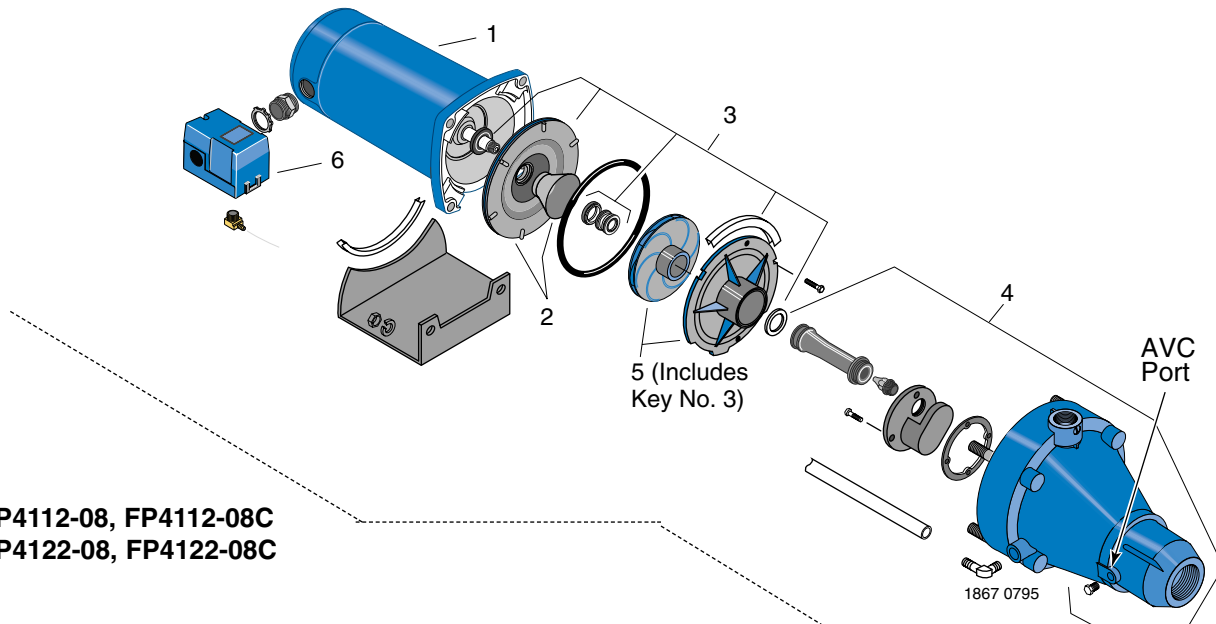

FP4112-08, FP4112-08C
FP4122-08, FP4122-08C

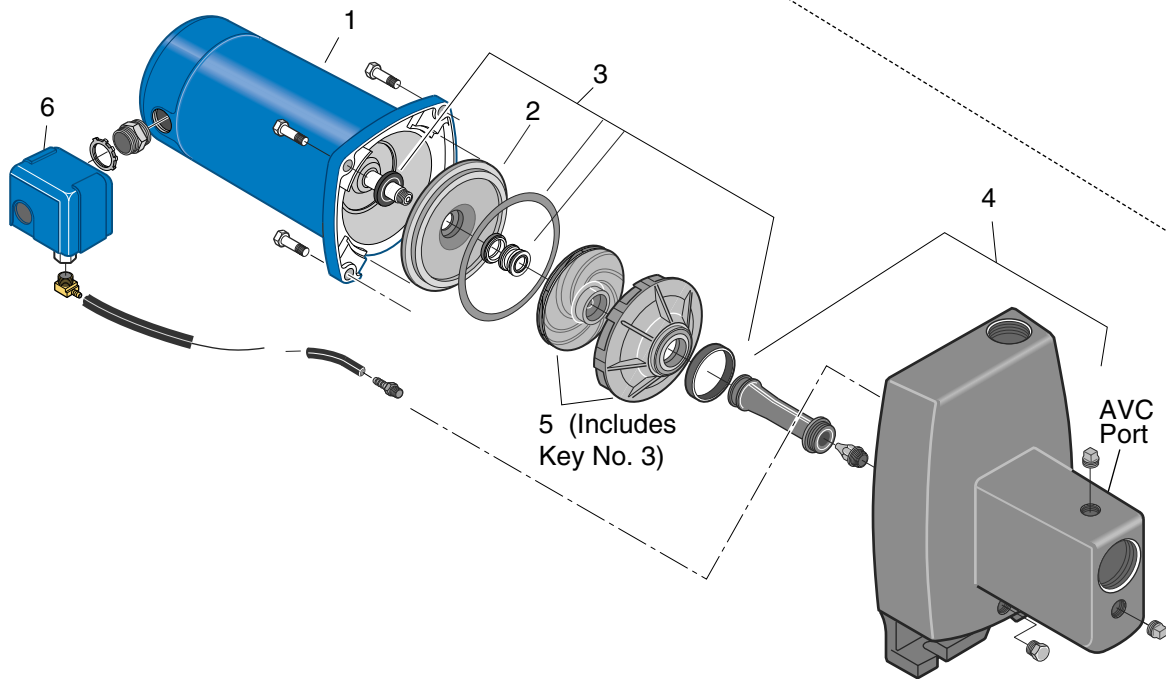

**Models FP4112-08, FP4112-08C, FP4122-08, FP4122-08C,
FP4012-08, FP4012-08C, FP4022-08, and FP4022-08C**

Key No.	Part Description	Cast Iron Model and HP		Corrosion Resistant Model and HP	
		FP4112-08 FP4112-08C 1/2HP	FP4122-08 FP4122-08C 3/4HP	FP4012-08*** FP4012-08C*** 1/2HP	FP4022-08 FP4022-08C 3/4HP
		1	Motor	AS100CL	A100DLL
2	Seal Plate Assembly*	N3-9	N3-9	N203-12P	N203-12P
3	Seal and Gasket Kit**	FPP1550	FPP1550	FPP1530	FPP1530
4	Pump Body Assembly§	N176-38	N176-38F	N176-35P	N176-35PA
5	Overhaul Kit§§	FPP1560	FPP1561	FPP1520	FPP1521
6	Pressure Switch	TC2151	TC2151	TC2151	TC2151

* Series FP4000 includes: Seal plate, O-Ring, and seal plate insert.

** Includes: Water slinger, seal plate O-Ring or gasket, shaft seal, and diffuser O-Ring or gasket. Series FP4000 includes diffuser pad also.

*** Included in model FP401215H-04 or FP401215H-04C (as applicable).

§ Includes: Pump body, nozzle, and venturi. Series FP4000 includes venturi O-Ring; does not include check valve.

§§ Includes: Seal and Gasket Kit (Key No. 3), impeller, and diffuser. Series FP4000 includes seal plate insert also.

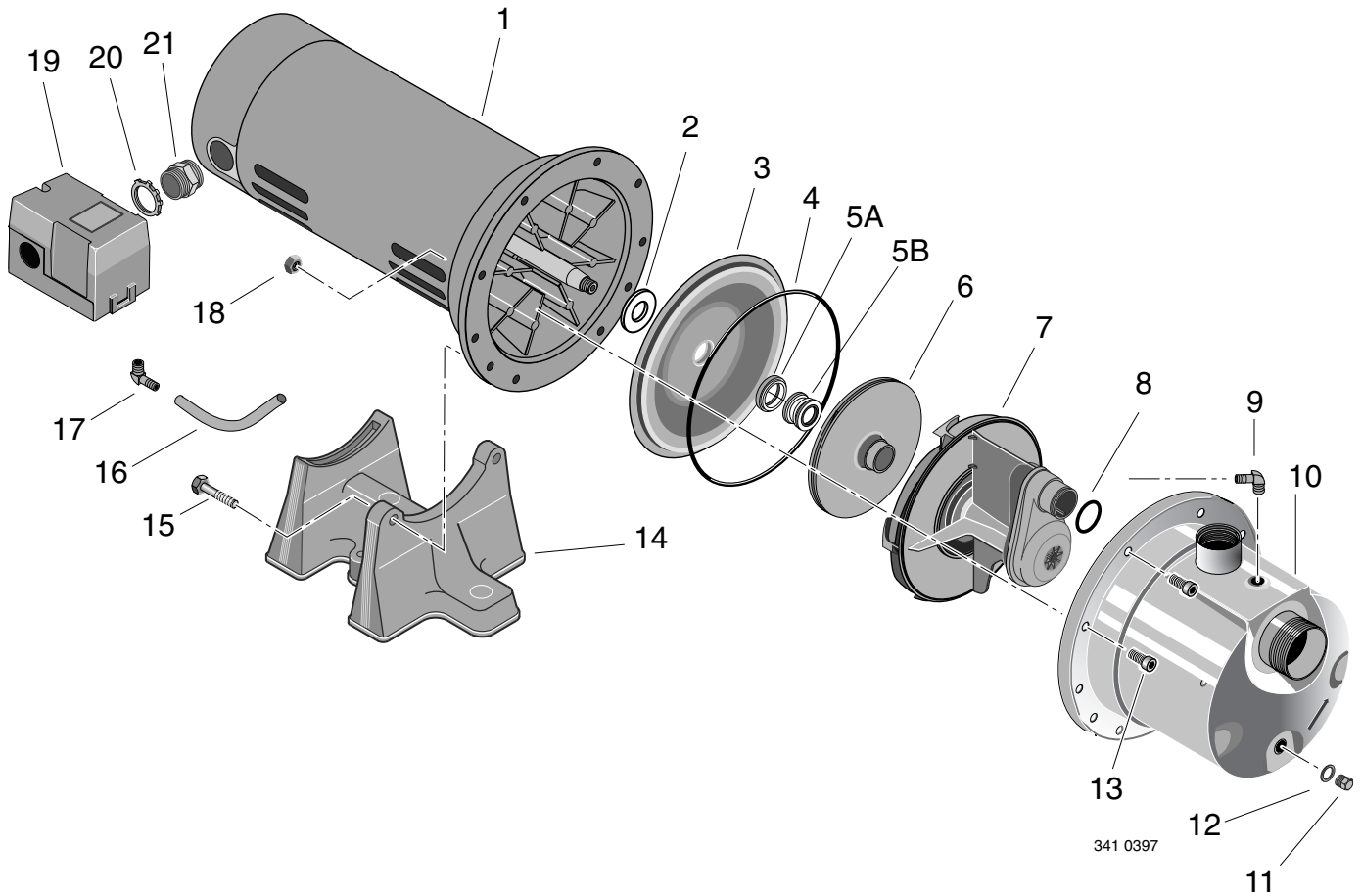

Models FP4822-08 and FP4832-08

Key No.	Part Description	No. Used	Model	
			FP4822-08 3/4 HP	FP4832-08 1 HP
1	Motor	1	J218-1006	J218-1007
2	Slinger	1	C69-7	C69-7
3	Seal Plate	1	784S0070	784S0070
4	O-Ring	1	111P0490	111P0490
5A	Shaft Seal Seat	1	111P0510	111P0510
5B	Shaft Seal Rotating	1	111P0500	111P0500
6	Impeller	1	101P1720	101P1730
7	Venturi	1	101P2900	101P2900
8	O-Ring	1	111P1100	111P1100
9	90° Hose Barb	1	171P4750T	171P4750T
10	Pump Body	1	723S0850	723S0850
11	Plug, Stainless Steel	1	121P2100	121P2100
12	Washer	1	111P0990	111P0990
13	Screw, Socket Head	8	121P0310	121P0310
14	Base	1	C4-42P	C4-42P
15	Bolt	2	U30-73SS	U30-73SS
16	Pressure Switch Tube	1	U37-677P	U37-677P
17	1/4" NPT 90° Hose Barb	1	U111-212T	U111-212T
18	Nut	8	U36-207SS	U36-207SS
19	Pressure Switch	1	U217-1202	U217-1202
20	1/2" Locknut	1	U36-112ZP	U36-112ZP
21	Connector	1	L43-5C	L43-5C

SYMPTOM	POSSIBLE CAUSE(S)	CORRECTIVE ACTION
Motor will not run	<p>Disconnect switch is off Fuse is blown or circuit breaker tripped Starting switch is defective Wires at motor are loose, disconnected, or wired incorrectly</p> <p>Pressure switch contacts are dirty</p>	<p>Be sure switch is on. Replace fuse or reset circuit breaker. DISCONNECT POWER; Replace starting switch. Refer to instructions on wiring (Page 8). DISCONNECT POWER; check and tighten all wiring.</p> <p>⚠️ WARNING Capacitor voltage may be hazardous. To discharge capacitor, hold insulated handle screwdriver BY THE HANDLE and short capacitor terminals together. Do not touch metal screwdriver blade or capacitor terminals. If in doubt, consult a qualified electrician. DISCONNECT POWER and file contacts with emery board or nail file.</p>
Motor runs hot and overload kicks off	<p>Motor is wired incorrectly Voltage is too low</p> <p>Pump cycles too frequently</p>	<p>Refer to instructions on wiring. Check with power company. Install heavier wiring if wire size is too small (See Electrical / Wiring Chart). See section below on too frequent cycling.</p>
<p>Motor runs but no water is delivered*</p> <p>* (Note: <i>Stop pump</i>; then check prime before looking for other causes. Unscrew priming plug and see if water is in priming hole).</p>	<p>Pump in new installation did not pick up prime through: 1. Improper priming 2. Air leaks</p> <p>3. Leaking foot valve or check valve Pump has lost prime through: 1. Air leaks 2. Water level below suction pipe inlet</p> <p>Foot valve or strainer is plugged Ejector or impeller is plugged Check valve or foot valve is stuck shut Pipes are frozen Foot valve and/or strainer are buried in sand or mud Water level is too low for shallow well setup to deliver water</p>	<p>In new installation:</p> <ol style="list-style-type: none"> 1. Re-prime according to instructions. 2. Check all connections on suction line, AVC, and ejector with soapy water or shaving cream. 3. Replace foot valve or check valve. <p>In installation already in use:</p> <ol style="list-style-type: none"> 1. Check all connections on suction line and shaft seal. 2. Lower suction line into water and re-prime. If receding water level in well exceeds 25' (7.6M), a deep well pump is needed. <p>Clean foot valve or strainer. Clean ejector or impeller. Replace check valve or foot valve. Thaw pipes. Bury pipes below frost line. Heat pit or pump house. Raise foot valve and/or strainer above bottom of water source. Clean foot valve and strainer. A deep well jet package may be needed (over 25 ft. to water) to deliver water.</p>
Pump does not deliver water to full capacity	<p>Water level in well is lower than estimated Steel piping (if used) is corroded or limed, causing excess friction Piping is too small in size Packed well point</p>	<p>A deep well jet will be needed if your well is more than 25' (7.6M) depth to water. Replace with plastic pipe where possible, otherwise with new steel pipe.</p> <p>Use larger piping. Backflush well point or sink new point.</p>
Pump delivers water but does not shut off or pump cycles too frequently	<p>Pressure switch is out of adjustment or contacts are welded together Faucets have been left open Venturi, nozzle or impeller is clogged Standard pressure tank is waterlogged and has no air cushion Pipes leak Foot valves leak Air charge too low in pre-charged tank</p>	<p>DISCONNECT POWER; adjust or replace pressure switch.</p> <p>Close faucets. Clean venturi, nozzle or impeller. Drain tank to air volume control port. Check AVC for defects. Check all connections for air leaks. Check connections. Replace foot valve. DISCONNECT POWER and open faucets until all pressure is relieved. Using tire pressure gauge, check air pressure in tank at valve stem located on the tank. If less than pressure switch cut-in setting (30-50 PSI), pump air into tank from outside source until air pressure is 2 PSI less than cut-in setting of switch. Check air valve for leaks (use soapy solution) and replace core if necessary.</p>
Air spurts from faucets	<p>Pump is picking up prime Leak in suction side of pump Well is gaseous Intermittent over-pumping of well. (Water drawn down below foot valve.)</p>	<p>When pump has picked up prime, it should pump solid water with no air. Suction pipe is sucking air. Check joints for leaks with soapy water. Consult factory about installing a sleeve in the well Lower foot valve if possible, otherwise restrict pump discharge</p>