



P.O. Box 342, Delavan, WI 53115  
Phone: 1-800-365-6832  
Fax: 1-800-526-3757  
E-Mail: flotec@flotecpump.com  
Web Site: http://www.flotecwater.com

Water  
is Our  
Business™

OWNER'S MANUAL  
Convertible Deep Well Jet Pumps

NOTICE D'UTILISATION  
Pompe à éjecteur transformables  
pour puits profonds

MANUAL DEL USUARIO  
Bombas Convertibles tipo "Jet"  
para Pozos Profundos

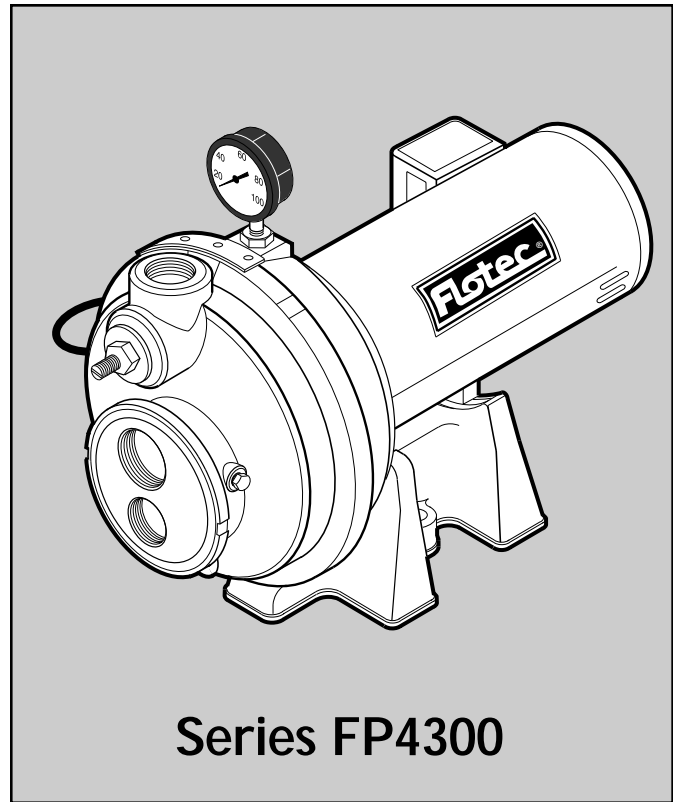
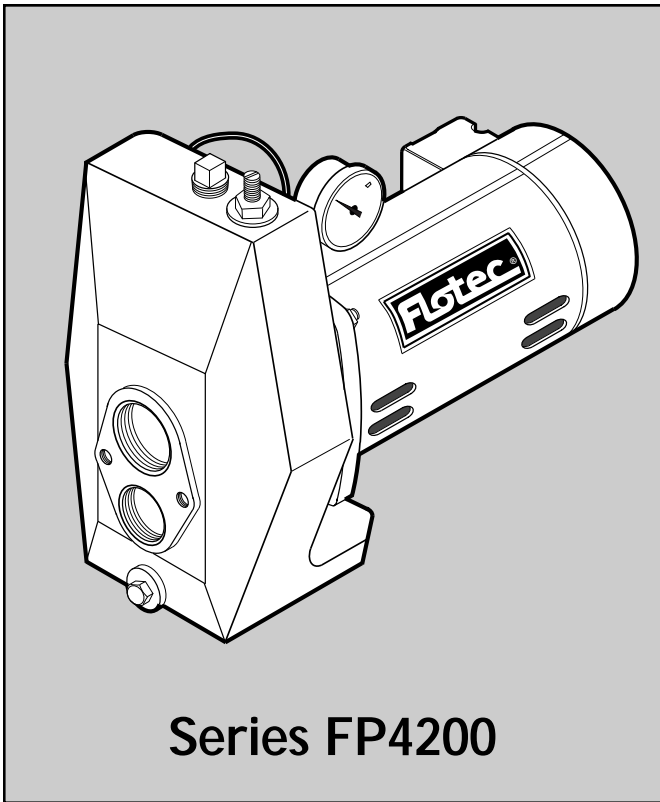

Installation/Operation/Parts

For further operating, installation, or maintenance assistance:

Call 1-800-365-6832

English ..... Pages 2-14

Installation/Fonctionnement/Pièces

Pour plus de renseignements concernant l'utilisation, l'installation ou l'entretien,

Composer le 1 (800) 365-6832

Français ..... Pages 15-27

Instalación/Operación/Piezas

Para mayor información sobre el funcionamiento, instalación o mantenimiento de la bomba:

Llame al 1-800-365-6832

Español ..... Páginas 28-40

## READ AND FOLLOW SAFETY INSTRUCTIONS!

**⚠** This is the safety alert symbol. When you see this symbol on your pump or in this manual, look for one of the following signal words and be alert to the potential for personal injury:

**⚠ DANGER** warns about hazards that **will** cause serious personal injury, death or major property damage if ignored.

**⚠ WARNING** warns about hazards that **can** cause serious personal injury, death or major property damage if ignored.

**⚠ CAUTION** warns about hazards that **will** or **can** cause minor personal injury or property damage if ignored.

The label **NOTICE** indicates special instructions which are important but not related to hazards.

**Carefully read and follow all safety instructions in this manual and on pump.**

Keep safety labels in good condition.  
Replace missing or damaged safety labels.

## ELECTRICAL SAFETY

**⚠ WARNING** Capacitor voltage may be hazardous. To discharge motor capacitor, hold insulated handle screwdriver **BY THE HANDLE** and short capacitor terminals together. Do not touch metal screwdriver blade or capacitor terminals. If in doubt, consult a qualified electrician.

## GENERAL SAFETY

**⚠ CAUTION** Do not touch an operating motor. Modern motors are designed to operate at high temperatures. To avoid burns when servicing pump, allow it to cool for 20 minutes after shut-down before handling.

Do not allow pump or any system component to freeze. To do so will void warranty.

Pump water only with this pump.

Periodically inspect pump and system components.

Wear safety glasses at all times when working on pumps.

Keep work area clean, uncluttered and properly lighted; store properly all unused tools and equipment.

Keep visitors at a safe distance from the work areas.

**⚠ WARNING** Pump body may explode if used as a booster pump unless relief valve capable of passing full pump flow at 75 psi is installed.

**⚠ WARNING**



**Hazardous voltage. Can shock, burn, or cause death.**

Ground pump before connecting to power supply. Disconnect power before working on pump, motor or tank.

- ⚠** Wire motor for correct voltage. See "Electrical" section of this manual and motor nameplate.
- ⚠** Ground motor before connecting to power supply.
- ⚠** Meet National Electrical Code, Canadian Electrical Code, and local codes for all wiring.
- ⚠** Follow wiring instructions in this manual when connecting motor to power lines.

**⚠ WARNING**



**Hazardous pressure! Install pressure relief valve in discharge pipe.**

Release all pressure on system before working on any component.

*Thank you for purchasing a top quality, factory tested pump.*

	Page
General Safety .....	2
Warranty .....	3
Replacing An Existing Pump .....	4
New Shallow Well Installation .....	5,6
• Well Point (Driven Point)	
• Cased Well, 2" or larger casing	
• Installation for Surface Water	
New Deep Well Installation .....	7
• 4-inch or larger well casing (A "Double Pipe" Well)	
• 2-inch well casing (A "Single Pipe" Well)	
Discharge Pipe and Pressure Tank Connections .....	8
Electrical .....	9,10
Preparing To Start The Pump – Deep Well .....	11
Preparing To Start The Pump – Shallow Well .....	12
Troubleshooting .....	13
Repair Parts .....	14

**ATTACH ORIGINAL RECEIPT HERE FOR WARRANTY CONSIDERATION.**

**Flotec Limited Warranty**

FLOTEC warrants to the original consumer purchaser ("Purchaser") of its products that they are free from defects in material or workmanship.

If within twelve (12) months from the date of the original consumer purchase any such product shall prove to be defective, it shall be repaired or replaced at FLOTEC's option, subject to the terms and conditions set forth below. Your dated proof of purchase will be used to determine warranty eligibility.

**Exceptions to the Twelve (12) Month Warranty**

***Ninety (90) Day Warranty:***

If within ninety (90) days from original consumer purchase any Drill Pump or In-Line Water Filter Cartridge shall prove to be defective, it shall be replaced, subject to the terms set forth below.

***Three (3) Year Warranty:***

If within three (3) years from original consumer purchase any 4" Submersible Well Pump shall prove to be defective, it shall be repaired or replaced at FLOTEC's option, subject to the terms set forth below.

***Five (5) Year Warranty:***

If within five (5) years from original consumer purchase any Pre-Charge water system tank shall prove to be defective, it shall be repaired or replaced at FLOTEC's option, subject to the terms and conditions set forth below.

**General Terms and Conditions**

Purchaser must pay all labor and shipping charges necessary to replace product covered by this warranty. This warranty shall not apply to acts of God, nor shall it apply to products which, in the sole

judgement of FLOTEC, have been subject to negligence, abuse, accident, misapplication, tampering, alteration; nor due to improper installation, operation, maintenance or storage; nor to other than normal application, use of service, including but not limited to, operational failures caused by corrosion, rust or other foreign materials in the system, or operation at pressures in excess of recommended maximums.

Requests for service under this warranty shall be made by returning the defective product to the Retail outlet or to FLOTEC as soon as possible after the discovery of any alleged defect. FLOTEC will subsequently take corrective action as promptly as reasonably possible. No requests for service under this warranty will be accepted if received more than 30 days after the term of the warranty.

This warranty sets forth FLOTEC's sole obligation and purchaser's exclusive remedy for defective products.

FLOTEC SHALL NOT BE LIABLE FOR ANY CONSEQUENTIAL, INCIDENTAL, OR CONTINGENT DAMAGES WHATSOEVER.

THE FOREGOING WARRANTIES ARE EXCLUSIVE AND IN LIEU OF ALL OTHER EXPRESS WARRANTIES, IMPLIED WARRANTIES, INCLUDING BUT NOT LIMITED TO THE IMPLIED WARRANTIES OF MERCHANTABILITY AND FITNESS FOR A PARTICULAR PURPOSE, SHALL NOT EXTEND BEYOND THE DURATION OF THE APPLICABLE EXPRESS WARRANTIES PROVIDED HEREIN.

Some states do not allow the exclusion or limitation of incidental or consequential damages or limitations on how long an implied warranty lasts, so the above limitations or exclusions may not apply to you. This warranty gives you specific legal rights and you may also have other rights which vary from state to state.

FLOTEC • P.O. Box 342 • Delavan, WI U.S.A. 53115

Phone: 1-800-365-6832 • Fax: 1-800-526-3757

E-Mail: [flotec@flotecpump.com](mailto:flotec@flotecpump.com) • Web Site: <http://www.flotecwater.com>

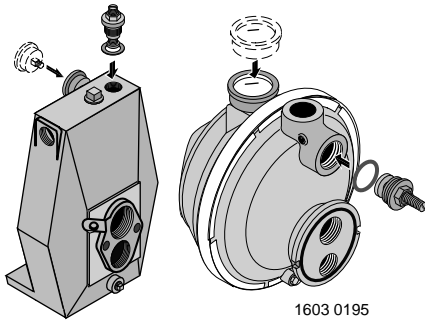

**Figure 1: Install Control Valve and Gauge**

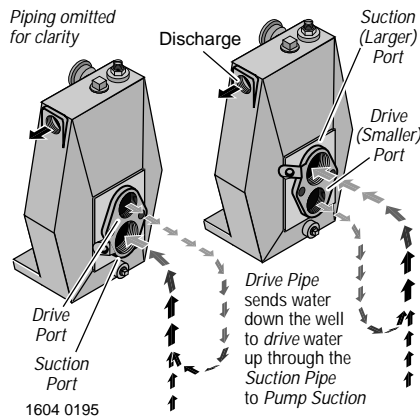

**Figure 2: Drive and Suction Functions**

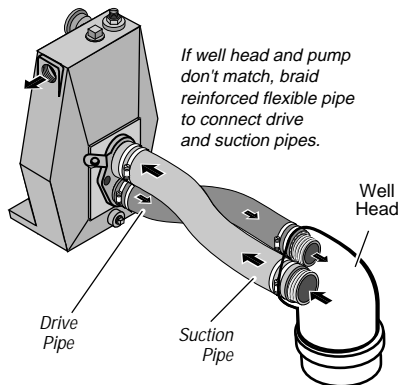

**Figure 3: Reversed Connections to Well**

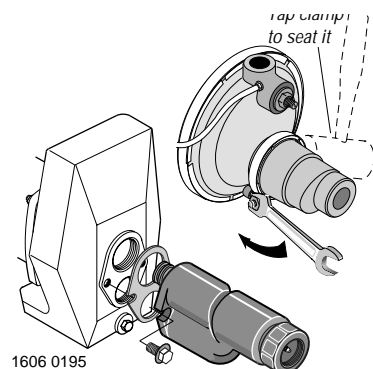

**Figure 4: Mount Ejector – Shallow Well**

## DEEP WELL

**⚠ WARNING** Hazardous voltage. Disconnect power to pump before working on pump or motor.

- Step 1. Drain and remove the old pump. Check pipe for scale, lime, rust, etc., and replace it if necessary.
- Step 2. Install the control valve and pressure gauge in the pump body (see Figure 1).
- Step 3. If your old pump has the suction pipe (the larger port – see Figure 2) below the drive port, you will need to install flexible pipe between the well head and the pump so that the connection will be correct. (See Figure 3).

**NOTICE:** Your old ejector (in the well) may not be properly matched to your new pump. If the pump does not perform properly, we recommend that you install Flotec ejector kit FP4800.

- Step 4. Install the pump in the system. Make sure that all pipe joints in the suction pipe are air-tight as well as water tight. If the suction pipe can suck air, the pump will not be able to pull water from the well.
- Step 5. Adjust the pump mounting height so that the plumbing connections do not put a strain on the pump body. Support the pipe so that the pump body does not take the weight of piping or fittings.

**You have just completed the well plumbing for your new deep well jet pump. Please go to Page 8 for discharge pipe and tank connections.**

## SHALLOW WELL

**⚠ WARNING** Hazardous voltage. Disconnect power to pump before working on pump or motor.

- Step 1. Drain and remove the old pump. Check the old pipe for scale, lime, rust, etc., and replace it if necessary.
- Step 2. Install the control valve and pressure gauge in the pump body (see Figure 1).
- Step 3. Install ejector kit FP4855 with a Series 4200, or kit FP4875 with a Series 4300 pump (kits are sold separately). Follow the instructions provided with the kit. Be sure to align the venturi with the top hole on the front of the pump (see Figure 4).

**NOTICE:** Always replace the ejector when replacing the pump in a shallow well installation.

- Step 4. Install the pump in the system. Make sure that all pipe joints in the suction pipe are air-tight as well as water tight. If the suction pipe can suck air, the pump will not be able to pull water from the well.
- Step 5. Adjust the pump mounting height so that the plumbing connections do not put a strain on the pump body. Support the pipe so that the pump body does not take the weight of piping or fittings.

**You have just completed the well plumbing for your new shallow well jet pump. Please go to Page 8 for discharge pipe and tank connections.**

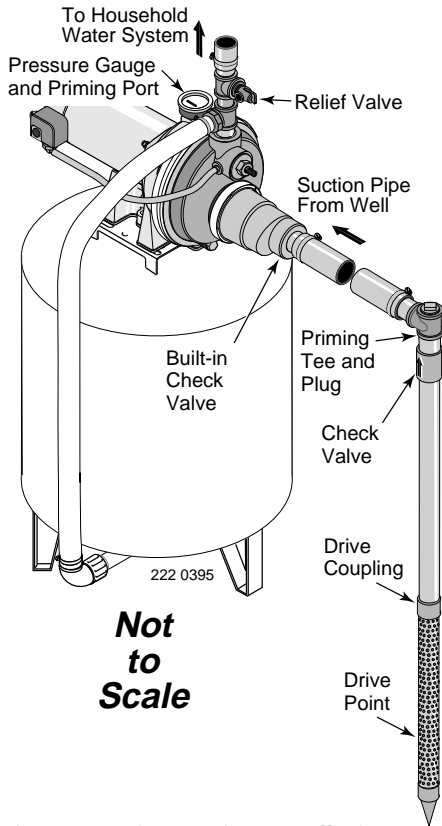

Figure 5: Driven Point Installation

## WELL POINT INSTALLATION (Figure 5)

- Step 1. Install the control valve and pressure gauge in the pump body (see Figure 1).
- Step 2. Install ejector kit FP4855 with a Series 4200 pump, or kit FP4875 with a Series 4300 pump (kits are sold separately). Follow the instructions provided with the kit. Align the venturi with the top hole on the front of the pump (see Figure 4).
- Step 3. Drive the well, using “drive couplings” and a “drive cap”. “Drive fittings” are threaded all the way through and allow the pipe ends to butt against each other so that the driving force of the maul is carried by the pipe and not by the threads. The ordinary fittings found in hardware stores are not threaded all the way through the fitting and can collapse under impact. “Drive fittings” are also smoother than standard plumbing fittings, making ground penetration easier.
- Step 4. Mount the pump as close to the well as possible.
- Step 5. Use the fewest possible fittings (especially elbows) when connecting the pipe from the well point to the pump suction port. The suction pipe should be at least as large as the suction port on the pump (include a check valve – see Figure 5). Support the pipe so that there are no dips or sags in the pipe, so it doesn’t strain the pump body, and so that it slopes slightly upward from the well to the pump (high spots can cause air pockets which can air lock the pump). Seal the suction pipe joints with teflon tape or pipe joint compound approved for use on PVC. Joints must be air- and water-tight. If the suction pipe can suck air, the pump cannot pull water from the well. If one well point does not supply enough water, consider connecting two or three well points to one suction pipe.

**You have just completed the suction piping for your new shallow well jet pump. Please go to Page 8 for discharge pipe and tank connections**

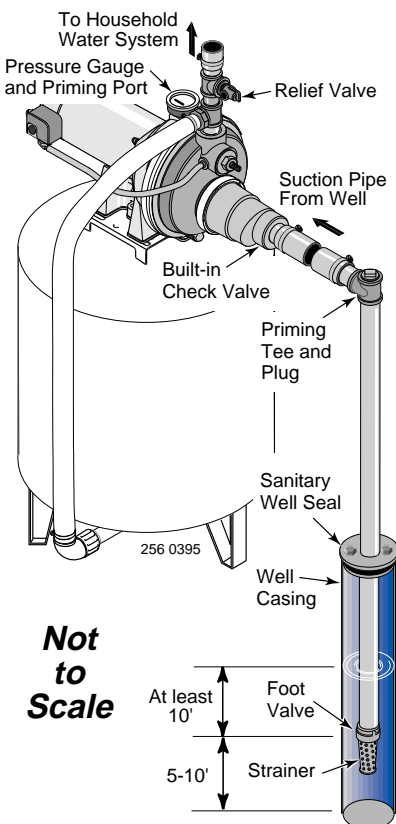
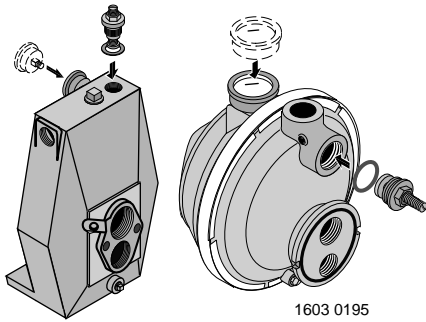

Figure 6: Cased Well Installation

## CASED WELL INSTALLATION, 2" OR LARGER CASING (Figure 6)

- Step 1. Install the control valve and pressure gauge in the pump body (see Figure 1).
- Step 2. Install ejector kit FP4855 with a Series 4200 pump, or kit FP4875 with a Series 4300 pump (kits are sold separately). Follow the instructions provided with the kit. Align the venturi with the top hole on the front of the pump (see Figure 4).
- Step 3. Mount the pump as close to the well as possible.
- Step 4. Assemble the foot valve, strainer, and well pipe (see Figure 6). Make sure that the foot valve works freely.
- Step 5. Lower the pipe into the well until the strainer is five feet above the bottom of the well. It should also be at least 10 feet below the well’s water level while the pump is running in order to prevent the pump from sucking air. Install a sanitary well seal.
- Step 6. Install a priming tee, priming plug, and suction pipe to the pump (see Figure 6). Connect the pipe from the well to the pump suction port, using the fewest possible fittings – especially elbows – as fittings increase friction in the pipe. The suction pipe should be at least as large as the suction port on the pump. Use teflon tape or a



**Figure 7: Install Control Valve and Pressure Gauge**

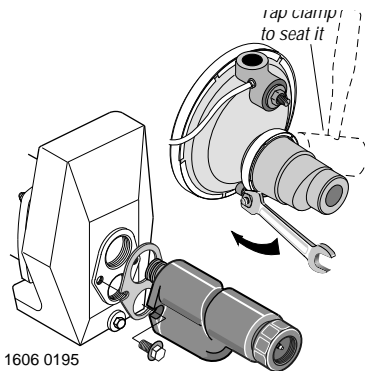

**Figure 8: Install Ejector**

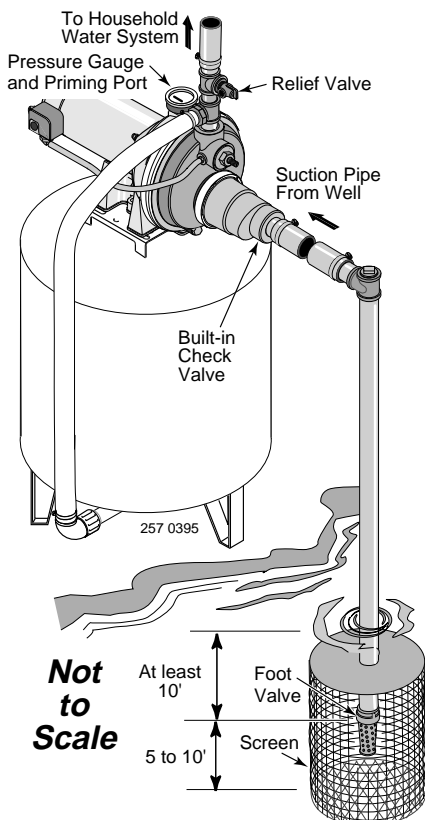

**Figure 9: Surface Water Installation**

teflon-based pipe joint compound on threaded pipe joints. Support the pipe so that there are no dips or sags in the pipe, so it doesn't strain the pump body, and so that it slopes slightly upward from the well to the pump (high spots can cause air pockets which can air lock the pump). Seal the suction pipe joints with teflon tape or a teflon based pipe joint compound. Joints must be air- and water-tight. If the suction pipe can suck air, the pump cannot pull water from the well.

**You have just completed the suction piping for your new shallow well jet pump. Please go to Page 8 for discharge pipe and tank connections.**

## INSTALLATION FOR SURFACE WATER

- Step 1. Install the control valve and pressure gauge in the pump body (see Figure 7).
- Step 2. Install ejector kit FP4855 with a Series 4200 pump, or kit FP4875 with a Series 4300 pump (kits are sold separately). Follow the instructions provided with the kit. Align the venturi with the top hole on the front of the pump (see Figure 8).
- Step 3. The pump should be installed as close to the water as possible, with the fewest possible fittings (especially elbows) in the suction pipe. The suction pipe should be at least as large as the suction port on the pump.
- Step 4. Assemble a foot valve and suction pipe (see Figure 9). Make sure that the foot valve works freely. Use teflon tape or a teflon-based pipe joint compound on threaded pipe joints. Protect the foot valve assembly from fish, trash, etc, by installing a screen around it (see Figure 9).
- Step 5. Lower the pipe into the water until the strainer is five feet above the bottom. It should also be at least 10 feet below the water level in order to prevent the pump from sucking air.
- Step 6. Install a priming tee, priming plug, and suction pipe to the pump (see Figure 9). Support the pipe so that there are no dips or sags in the pipe, so it doesn't strain the pump body, and so that it slopes slightly upward from the well to the pump (high spots can cause air pockets which can air lock the pump). Seal the suction pipe joints with teflon tape or a teflon based pipe joint compound. Joints must be air- and water-tight. If the suction pipe can suck air, the pump cannot pull water from the well.

**You have just completed the plumbing for your new shallow well jet pump. Please go to Page 8 for discharge pipe and tank connections.**

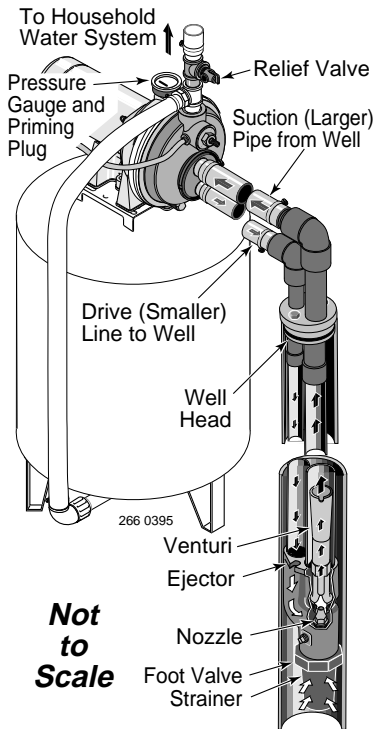

Figure 10: 4" and Larger Deep Well

## 4" OR LARGER WELL (Figure 10)

- Step 1. Install the control valve and pressure gauge in the pump body. See Figure 7.
- Step 2. Assemble ejector kit FP4800 (sold separately). See Figure 10. Follow the instructions included with the kit in order to match the nozzle and venturi to your well conditions.
- Step 3. Mount the pump as close to the well as possible.
- Step 4. Connect two pipes (1" drive, 1-1/4" suction) to the ejector and lower the ejector into the well until it is five feet from the bottom. It should also be at least 10 feet below the well's water level while the pump is running in order to prevent the pump from sucking air.
- Step 5. Install a sanitary well seal and connect the ejector piping to the pump. Use steel nipples through the well seal with flexible poly pipe to avoid crushing the plastic pipe when tightening the seal.
- Step 6. Support the pipe so that there are no dips or sags in the pipe, so it doesn't strain the pump body, and so that it slopes slightly upward from the well to the pump (high spots can cause air pockets which can air lock the pump). Seal the suction pipe joints with teflon tape or a teflon based pipe joint compound. Joints must be air- and water-tight. If the suction pipe can suck air, the pump cannot pull water from the well.

You have just completed the plumbing for your new double pipe deep well jet pump. Please go to Page 8 for discharge pipe and tank connections.

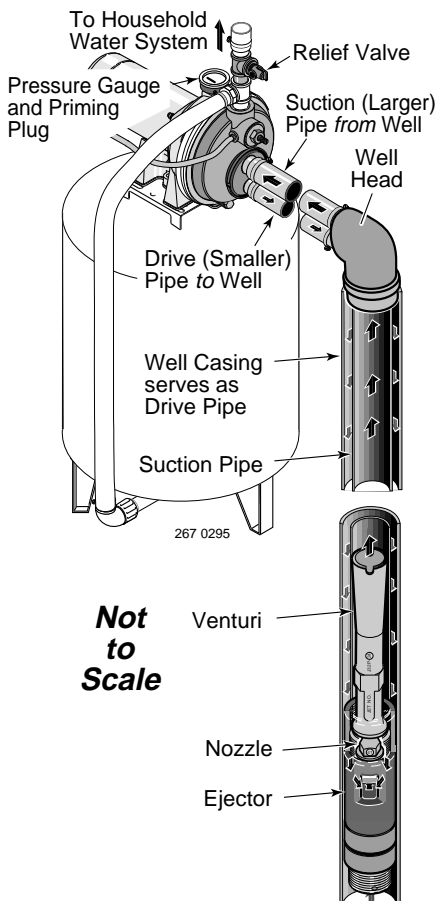
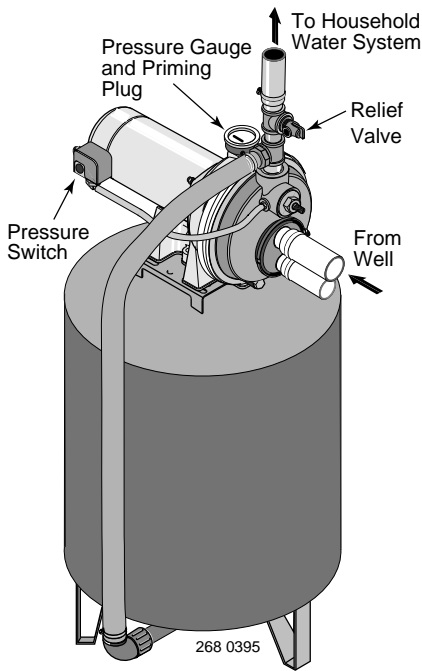

Figure 11: 2" (Single Pipe) Deep Well

## 2" WELL (Figure 11)

- Step 1. Install the control valve and pressure gauge in the pump body. See Figure 7.
- Step 2. Mount the pump as close to the well as possible.
- Step 3. Assemble ejector kit FP4840 (sold separately), well piping, and well head adapter according to the instructions provided with the ejector package. See Figure 11. Use galvanized drop pipe with turned couplings to allow proper flow. Follow the instructions included with the kit in order to match the nozzle and venturi to your well conditions.
- Step 4. Run two pipes (one smaller drive pipe, one larger suction pipe) from the well to the pump. Support the pipe so that there are no dips or sags in the pipe, so it doesn't strain the pump body, and so that it slopes slightly upward from the well to the pump (high spots can cause air pockets which can air lock the pump). Seal the suction pipe joints with teflon tape or a teflon based pipe joint compound. Joints must be air- and water-tight. If the suction pipe can suck air, the pump cannot pull water from the well.

You have just completed the plumbing for your new single pipe deep well jet pump. Please go to Page 8 for discharge pipe and tank connections.



**Figure 12: Pre-charged Tank Connections**

## PRE-CHARGE TANK CONNECTION (Figure 12)

- Step 1. Install a close nipple and a tee in the pump discharge port (see Figure 12). The pipe size must be at least as large as the discharge port. Run a pipe or reinforced hose from one arm of the tee to the port on the pre-charged tank.
- Step 2. Install a second close nipple and tee with a relief valve in the tee.
- Step 3. Connect the other end of the second discharge tee to your plumbing system.
- Step 4. Check the pre-charge of air in the tank with an ordinary tire gauge. The pre-charge should be 2 PSI less than the cut-in setting of the pump's pressure switch. The pre-charge is measured *when there is no water pressure in the tank*. Your new pump has a 30/50 PSI switch, so adjust the tank pre-charge pressure to 28 PSI.

**You have just completed the tank connection for your jet pump. Please go to Pages 9 and 10 for electrical hookup.**

## STANDARD TANK CONNECTION (Figure 13)

- Step 1. Install a close nipple and a tee in the pump discharge port. Mount a relief valve in one arm of the tee.
- Step 2. Install a second close nipple and tee in the open arm of the first tee. Put a priming plug in one arm of the second tee.
- Step 3. Run a pipe from the open arm of the second tee to the inlet port of your tank. The pipe size must be at least as large as the pump discharge port.
- Step 4. Remove the 1/8" NPT pipe plug from the pump Air Volume Control (AVC) port (see Figure 13). Run tubing from the pump's AVC port to the port on the AVC mounted on the tank. See instructions provided with tank and AVC for details.

**You have just completed the tank connection for your jet pump. Please go to Pages 9 and 10 for electrical hookup.**

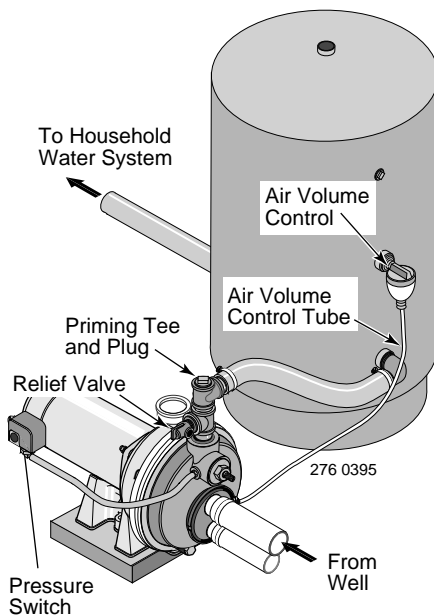

**Figure 13: Standard Tank Connections**

### Sealing Pipe Joints

Use only Teflon tape or Teflon based joint compounds for making all threaded connections to the pump itself. **Do not use pipe joint compounds on plastic pumps:** they can react with the plastic in pump components. Make sure that all pipe joints in the suction pipe are air tight as well as water tight. *If the suction pipe can suck air, the pump will not be able to pull water from the well.*

**⚠ Disconnect power before working on pump, motor, pressure switch, or wiring.**

Your Motor Terminal Board (under the motor end cover) and Pressure Switch look like one of those shown below. Convert to 115 Volts as shown. Do not change motor

wiring if line voltage is 230 Volts or if you have a single voltage motor. Connect power supply as shown for your type of switch and your supply voltage.

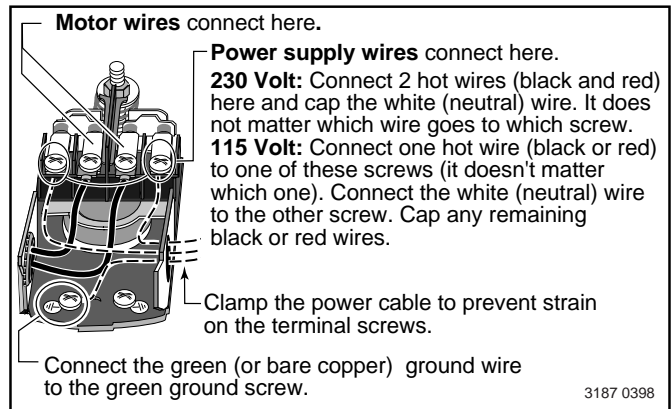
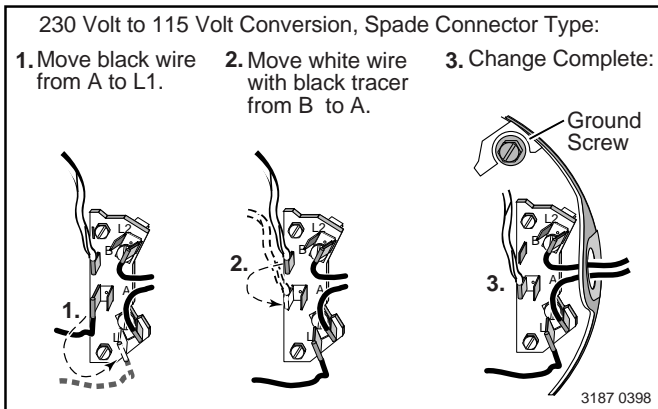
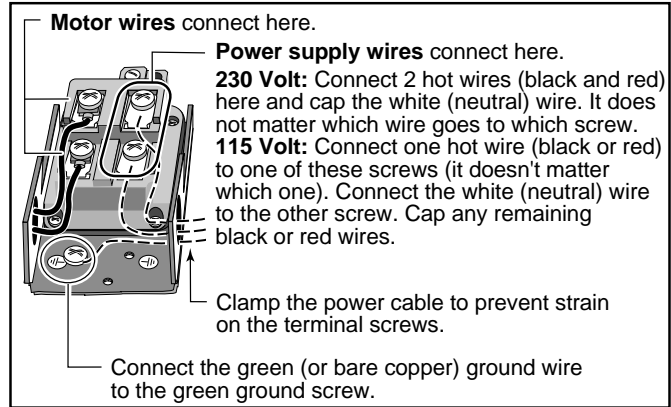
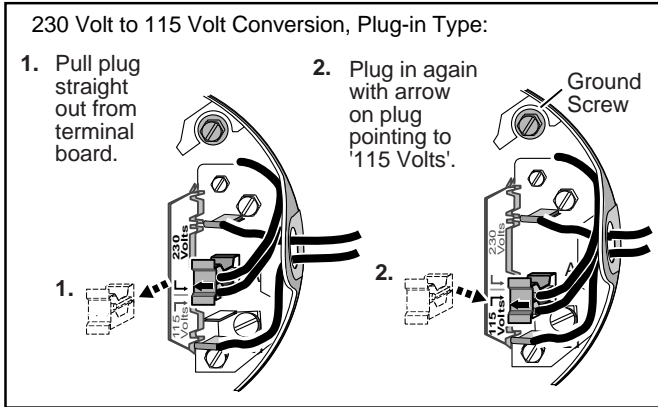

Figure 14: Motor wiring connections through Pressure Switch. Match motor voltage to line voltage.

**⚠ WARNING** Hazardous voltage. Can shock, burn, or kill. Connect ground wire before connecting power supply wires. Use the wire size (including the ground wire) specified in the wiring chart. If possible, connect the pump to a separate branch circuit with no other appliances on it.

**⚠ WARNING** Explosion hazard. Do not ground to a gas supply line.

## WIRING CONNECTIONS

**⚠ WARNING** Fire hazard. Incorrect voltage can cause a fire or seriously damage the motor and voids the warranty. The supply voltage must be within  $\pm 10\%$  of the motor nameplate voltage.

**NOTICE:** Dual-voltage motors are factory wired for 230 volts. If necessary, reconnect the motor for 115 volts, as shown. Do not alter the wiring in single voltage motors.

Install, ground, wire, and maintain your pump in compliance with the National Electrical Code (NEC) or the Canadian Electrical Code (CEC), as applicable, and with all local codes and ordinances that apply. Consult your local building inspector for code information.

**Connection Procedure:**

- Step 1. Connect the ground wire first as shown in Figure 14. The ground wire must be a solid copper wire at least as large as the power supply wires.
- Step 2. There must be a solid metal connection between the pressure switch and the motor for motor grounding protection. If the pressure switch is not connected to the motor, connect the green ground screw in the switch to the green ground screw under the motor end cover. Use a solid copper wire at least as large as the power supply wires.
- Step 3. Connect the ground wire to a grounded lead in a service panel, to a metal underground water pipe, to a metal well casing at least ten feet (3M) long, or to a ground electrode provided by the power company or the hydro authority.
- Step 4. Connect the power supply wires to the pressure switch as shown in Figure 14.

**You have just completed the wiring for your pump.  
Please go to Page 11 or 12 for startup preparations.**

**Wiring Chart – Recommended Wire and Fuse Sizes**

Motor HP	Volts	Max. Load Amp	Branch Fuse Rating Amp	DISTANCE IN FEET FROM MOTOR TO SUPPLY					
				0 - 50	51 - 100	101 - 200	201 - 300	301 - 400	401 - 500
				AWG WIRE SIZE (mm <sup>2</sup> )					
1/3	115/230	9.4/4.7	15/15	14/14 (2/2)	14/14 (2/2)	12/14 (3/2)	10/12 (5/3)	8/12 (7/3)	8/10 (7/5)
1/2	115/230	9.4/4.7	15/15	14/14 (2/2)	14/14 (2/2)	12/14 (3/2)	10/12 (5/3)	8/12 (7/3)	8/10 (7/5)
3/4	115/230	12.2/6.1	20/15	14/14 (2/2)	14/14 (2/2)	10/14 (5/2)	8/14 (7/2)	8/14 (7/2)	6/12 (9/3)
1	115/230	14.8/7.4	20/15	14/14 (2/2)	12/14 (3/2)	10/14(5/2)	8/12 (7/3)	8/12 (7/3)	6/12 (9/3)

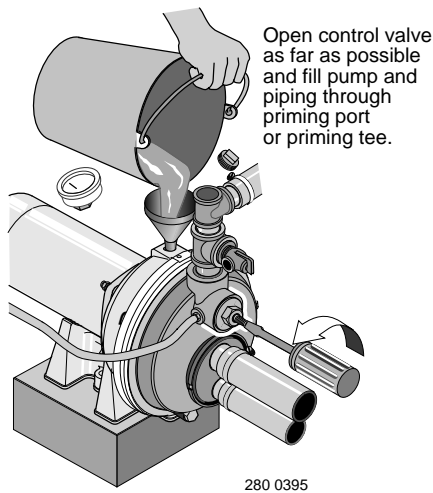

**Figure 15: Fill Pump**

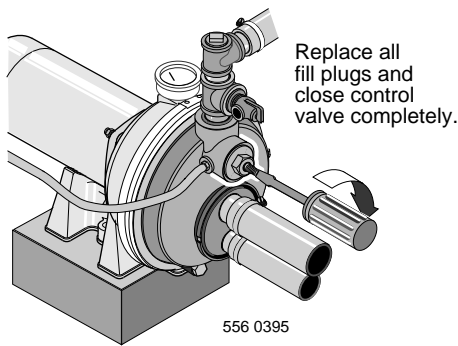

**Figure 16: Prime Pump**

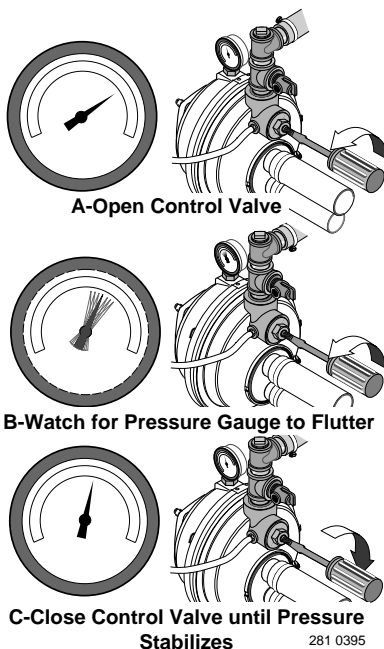

**Figure 17: Set Control Valve**

**CAUTION** Never run pump dry. Running pump without water may cause pump to overheat, damaging seal and possibly causing burns to persons handling pump. Fill pump with water before starting.

**WARNING** Never run pump against closed discharge. To do so can boil water inside pump, causing hazardous pressure in unit, risk of explosion and possibly scalding persons handling pump.

Step 1. Open the control valve as far as possible (see Figure 15). Then remove the priming plug from the pump and fill the pump, fill all piping between the pump and the well, and make sure that all piping in the well is full. If you have also installed a priming tee in the suction piping, remove the plug from the tee and fill the suction piping.

Step 2. Replace all fill plugs and close the control valve completely (Figure 16).

Step 3. Power on! Start the pump and watch the pressure gauge. The pressure should build rapidly to 50 PSI as the pump primes.

Step 4. After 2 or 3 minutes, the gauge should show pressure. If not, stop the pump, remove the fill plugs, reopen the control valve, and refill the pump and piping. You may have to repeat this two or three times in order to get all the trapped air out of the piping. Don't forget to close the control valve each time before you start the pump.

Step 5. When pressure has built up and stabilized at about 50 PSI, slowly open the control valve (see Figure 17) and let the pressure drop until the pressure gauge needle starts to flutter. When the needle flutters, close the valve just enough to stop the flutter (see Figure 17). Your pump is now operating at its most efficient point.

Step 6. After the pump has built up pressure in the system and shut off, check the pressure switch operation by opening a faucet or two and running enough water out to bleed off pressure until the pump starts. The pump should start when pressure drops to 30 PSI and stop when pressure reaches 50 PSI. Run the pump through one or two complete cycles to verify correct operation. This will also help clean the system of dirt and scale dislodged during installation.

**Congratulations on a successful installation.**

If you were unsuccessful, please refer to the Troubleshooting section (Page 13) or call our customer service technical staff.

***Thank you for purchasing Flotec Products.***

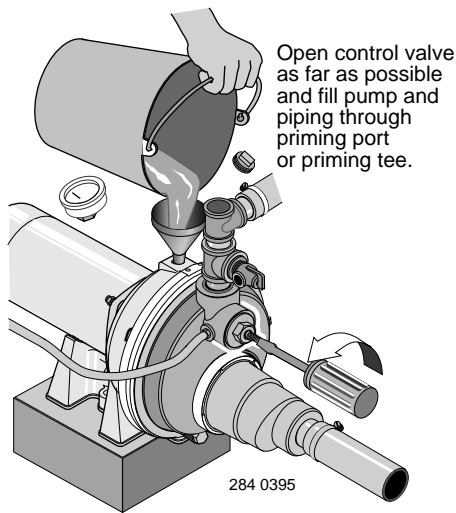

**Figure 18: Open Control Valve**

**⚠ CAUTION** **Never run pump dry.** Running pump without water may cause pump to overheat, damaging seal and possibly causing burns to persons handling pump. Fill pump with water before starting.

**⚠ WARNING** **Never run pump against closed discharge.** To do so can boil water inside pump, causing hazardous pressure in unit, risk of explosion and possibly scalding persons handling pump.

- Step 1. Open the control valve as far as possible (see Figure 18). Then remove the priming plug from the pump and fill the pump, fill all piping between the pump and the well, and make sure that all piping in the well is full. If you have also installed a priming tee in the suction piping, remove the plug from the tee and fill the suction piping.
- Step 2. Replace all fill plugs. Leave the control valve open (in a shallow well installation, the control valve always stays open).
- Step 3. Power on! Start the pump. The pump should pump water in two or three minutes.
- Step 4. If you don't have water after 2 or 3 minutes, stop the pump and remove the fill plugs. Refill the pump and piping. You may have to repeat this two or three times in order to get all the trapped air out of the piping. The control valve remains open throughout this procedure.
- Step 5. After the pump has built up pressure in the system and shut off, check the pressure switch operation by opening a faucet or two and running enough water out to bleed off pressure until the pump starts. The pump should start when pressure drops to 30 PSI and stop when pressure reaches 50 PSI. Run the pump through one or two complete cycles to verify correct operation. This will also help clean the system of dirt and scale dislodged during installation.

**Congratulations on a successful installation.**

If you were unsuccessful, please refer to the Troubleshooting section (Page 13) or call our customer service technical staff.

*Thank you for purchasing Flotec Products.*

SYMPTOM	POSSIBLE CAUSE(S)	CORRECTIVE ACTION
Motor will not run	<p>Disconnect switch is off Fuse is blown or circuit breaker tripped Starting switch is defective Wires at motor are loose, disconnected, or wired incorrectly</p> <p>Pressure switch contacts are dirty</p>	<p>Be sure switch is on Replace fuse or reset circuit breaker DISCONNECT POWER; Replace starting switch Refer to instructions on wiring (Page 9). DISCONNECT POWER; check and tighten all wiring.</p> <p><b>⚠️ WARNING</b> Capacitor voltage may be hazardous. To discharge capacitor, hold insulated handle screwdriver BY THE HANDLE and short capacitor terminals together. Do not touch metal screwdriver blade or capacitor terminals. If in doubt, consult a qualified electrician. DISCONNECT POWER and file contacts with emery board or nail file.</p>
Motor runs hot and overload kicks off	<p>Motor is wired incorrectly Voltage is too low</p> <p>Pump cycles too frequently</p>	<p>Refer to instructions on wiring Check with power company. Install heavier wiring if wire size is too small (See Electrical / Wiring Chart).</p> <p>See section below on too frequent cycling</p>
<p>Motor runs but no water is delivered*</p> <p>* (Note: <i>Stop pump</i>; then check prime before looking for other causes. Unscrew priming plug and see if water is in priming hole).</p>	<p>Pump in new installation did not pick up prime through: 1. Improper priming 2. Air leaks 3. Leaking foot valve or check valve</p> <p>Pump has lost prime through: 1. Air leaks 2. Water level below suction pipe inlet</p> <p>Foot valve or strainer is plugged Ejector or impeller is plugged Check valve or foot valve is stuck shut Pipes are frozen Foot valve and/or strainer are buried in sand or mud Water level is too low for shallow well setup to deliver water</p>	<p>In new installation:</p> <ol style="list-style-type: none"> <li>1. Re-prime according to instructions</li> <li>2. Check all connections on suction line, AVC and ejector</li> <li>3. Replace foot valve or check valve</li> </ol> <p>In installation already in use:</p> <ol style="list-style-type: none"> <li>1. Check all connections on suction line and shaft seal</li> <li>2. Lower suction line into water and re-prime. If receding water level in well exceeds suction lift, a deep well pump is needed.</li> </ol> <p>Clean foot valve or strainer Clean ejector or impeller Replace check valve or foot valve Thaw pipes. Bury pipes below frost line. Heat pit or pump house. Raise foot valve and/or strainer above bottom of water source. Clean foot valve and strainer. A deep well jet package may be needed (over 25 ft. to water) to deliver water to full capacity</p>
Pump does not deliver water to full capacity	<p>Water level in deep well is lower than estimated Steel piping (if used) is corroded or limed, causing excess friction Piping is too small in size</p>	<p>Replace nozzle and venturi with correct combination for the well; lower the ejector to correct level in the well Replace with plastic pipe where possible, otherwise with new steel pipe</p> <p>Use larger piping</p>
Pump delivers water but does not shut off or pump cycles too frequently	<p>Pressure switch is out of adjustment or contacts are welded together Faucets have been left open Venturi, nozzle or impeller is clogged Water level in deep well is lower than estimated Standard pressure tank is waterlogged and has no air cushion Pipes leak Foot valves leak Air charge too low in pre-charged tank</p>	<p>DISCONNECT POWER; adjust or replace pressure switch</p> <p>Close faucets Clean venturi, nozzle or impeller</p> <p>Replace nozzle and venturi with correct combination for the well Drain tank to air volume control port. Check AVC for defects. Check for air leaks at any connection. Check connections Replace foot valve DISCONNECT POWER and open faucets until all pressure is relieved Using tire pressure gauge, check air pressure in tank at valve stem located on the tank. If less than pressure switch cut-in setting (30-50 PSI), pump air into tank from outside source until air pressure is 2 PSI less than cut-in setting of switch. Check air valve for leaks (use soapy solution) and replace core if necessary.</p>
Air spurts from faucets	<p>Pump is picking up prime Leak in suction side of pump Well is gaseous Intermittent over-pumping of well. (Water drawn down below foot valve.)</p>	<p>When pump picks up prime, all air will be ejected Suction pipe is sucking air. Check joints for leaks. Consult factory about installing a sleeve in the well Lower foot valve if possible, otherwise restrict pump discharge</p>

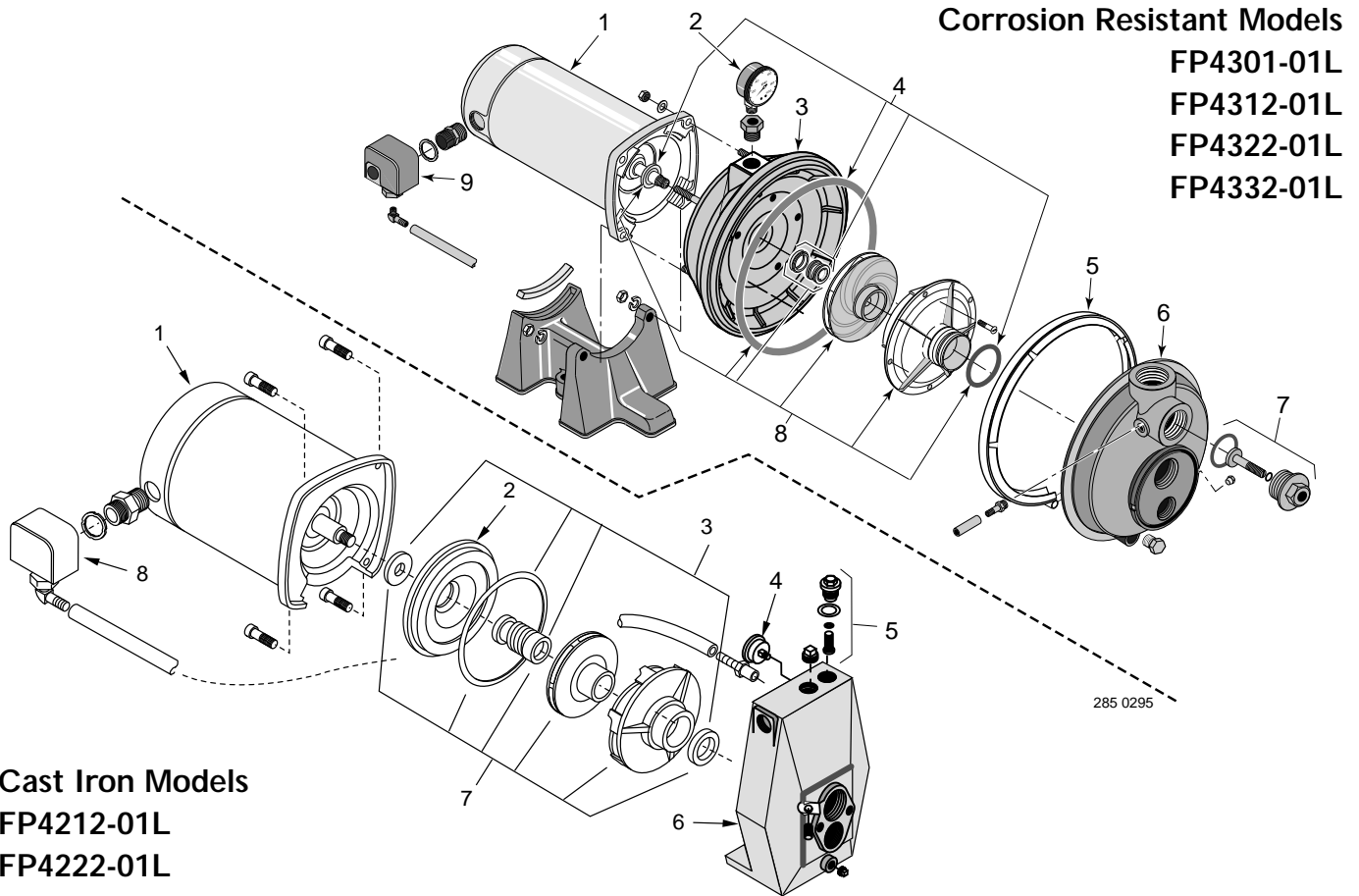

**Corrosion Resistant Models**  
 FP4301-01L  
 FP4312-01L  
 FP4322-01L  
 FP4332-01L

**Cast Iron Models**  
 FP4212-01L  
 FP4222-01L

Key No.	Part Description	Model and HP			
		FP4301-01L 1/3HP	FP4312-01L 1/2HP	FP4322-01L 3/4HP	FP4332-01L 1 HP
1	Motor	AS100BHL	A100CL	A100DL	A100EL
2	Pressure Gauge	TC2104	TC2104	TC2104	TC2104
3	Pump Body (Back Half)	L176-47P	L176-47P	L176-47P	L176-47P
4	Seal & Gasket Kit *	FPP1500	FPP1500	FPP1500	FPP1500
5	Clamp - Pump Body	C19-54SS	C19-54SS	C19-54SS	C19-54SS
6	Pump Body (Front Half)	L76-37P	L76-37P	L76-37P	L76-37P
7	Control Valve	L162-10PS	L162-10PS	L162-10PS	L162-10PS
8	Overhaul Kit **	FPP1511	FPP1511	FPP1512	FPP1513
9	Pressure Switch	TC2151	TC2151	TC2151	TC2151

Key No.	Part Description	Model and HP	
		FP4212-01L 1/2HP	FP4222-01L 3/4HP
1	Motor - 60 Cycle	A100CL	A100DL
2	Seal Plate	N3-9	N3-9
3	Seal & Gasket Kit *	FPP1550	FPP1550
4	Pressure Gauge	TC2104	TC2104
5	Control Valve	L262-4P	L262-4P
6	Pump Body Assembly	L76-44	L76-44
7	Overhaul Kit **	FPP1560	FPP1561
8	Pressure Switch	TC2151	TC2151

\* Includes: water slinger, seal plate O-ring or gasket, shaft seal, diffuser pad, and diffuser O-ring or gasket.  
 \*\* Includes: Seal and Gasket Kit plus seal plate insert, impeller and diffuser.  
 Repair instructions are included with all repair kits.