



P.O. Box 342, Delavan, WI 53115
Phone: 1-800-365-6832
Fax: 1-800-526-3757
E-Mail: flotec@flotecpump.com
Web Site: http://www.flotecwater.com

OWNER'S MANUAL
Self-Priming Centrifugal Pumps

NOTICE D'UTILISATION
Pompes centrifuges a amorçage automatique

MANUAL DEL USUARIO
Self-Priming Centrifugal Pumps

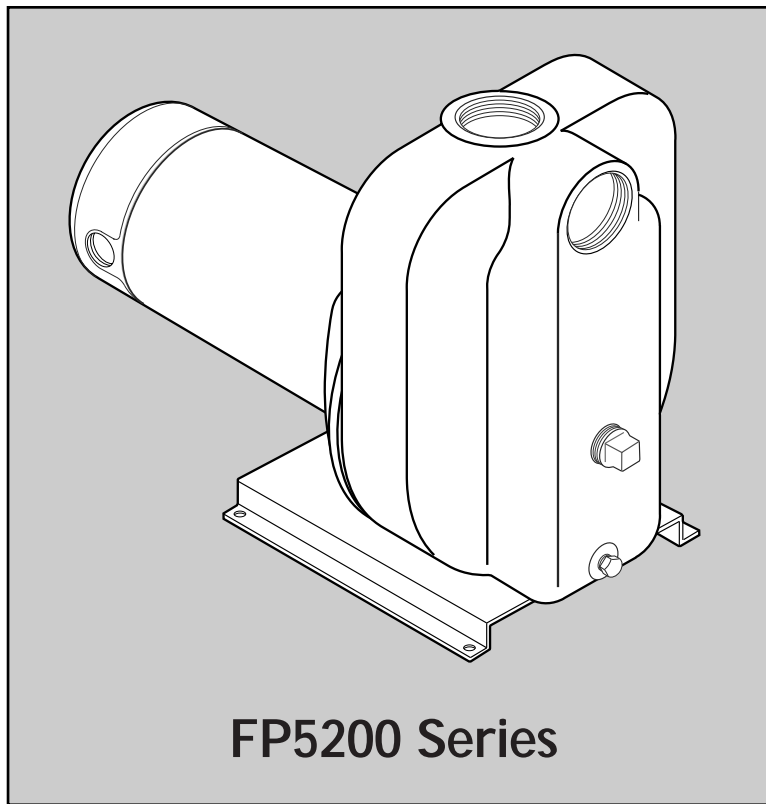

FP5200 Series

**Water
is Our
Business™**

Installation/Operation/Parts

For further operating, installation, or maintenance assistance:

Call 1-800-365-6832

English Pages 2-14

Installation/Fonctionnement/Pièces

Pour plus de renseignements concernant l'utilisation, l'installation ou l'entretien,

Composer le 1 (800) 365-6832

Français Pages 15-27

Instalación/Operación/Piezas

Para mayor información sobre el funcionamiento, instalación o mantenimiento de la bomba:

Llame al 1-800-365-6832

Español Páginas 28-40

READ AND FOLLOW SAFETY INSTRUCTIONS!

⚠ This is the safety alert symbol. When you see this symbol on your pump or in this manual, look for one of the following signal words and be alert to the potential for personal injury:

⚠ DANGER warns about hazards that **will** cause serious personal injury, death or major property damage if ignored.

⚠ WARNING warns about hazards that **can** cause serious personal injury, death or major property damage if ignored.

⚠ CAUTION warns about hazards that **will** or **can** cause minor personal injury or property damage if ignored.

The label **NOTICE** indicates special instructions which are important but not related to hazards.

Carefully read and follow all safety instructions in this manual and on pump.

Keep safety labels in good condition.

Replace missing or damaged safety labels.

Make workshops childproof; use padlocks and master switches, remove starter keys.

ELECTRICAL SAFETY

⚠ WARNING Capacitor voltage may be hazardous. To discharge motor capacitor, hold insulated handle screwdriver **BY THE HANDLE** and short capacitor terminals together. Do not touch metal screwdriver blade or capacitor terminals. If in doubt, consult a qualified electrician.

| |
|---|
|  |
| <p>⚠ WARNING</p> <p>Hazardous voltage. Can shock, burn, or cause death.</p> <p>Ground pump before connecting to power supply. Disconnect power before working on pump, motor.</p> |

⚠ Wire motor for correct voltage. See “Electrical” section of this manual and motor nameplate.

⚠ Ground motor before connecting to power supply.

⚠ Meet National Electrical Code, Canadian Electrical Code, and local codes for all wiring.

⚠ Follow wiring instructions in this manual when connecting motor to power lines.

GENERAL SAFETY

⚠ CAUTION Do not touch an operating motor. Modern motors are designed to operate at high temperatures. To avoid burns when servicing pump, allow it to cool for 20 minutes after shut-down before handling.

Pump is designed as a lawn sprinkler only. To avoid heat build-up, over pressure hazard and possible injury, do not use in a pressure tank (domestic water system). Do not use as a booster pump; pressurized suction may cause pump body to explode.

Do not allow pump or piping system to freeze. Freezing can damage pump and pipe, may lead to injury from equipment failure and will void warranty.

Pump water only with this pump.

Periodically inspect pump and system components.

Wear safety glasses at all times when working on pumps.

Keep work area clean, uncluttered and properly lighted; store properly all unused tools and equipment.

Keep visitors at a safe distance from the work areas.

| | |
|---|---|
|  | <p>⚠ WARNING</p> <p>Hazardous pressure! Install pressure relief valve in discharge pipe.</p> <p>Release all pressure on system before working on any component.</p> |
|---|---|

Thank you for purchasing a top quality, factory tested pump.

| | Page |
|----------------------|-------|
| General Safety | 2 |
| Warranty | 3 |
| Installation | 4-6 |
| Electrical | 7,8 |
| Operation | 9 |
| Maintenance | 10-12 |
| Troubleshooting..... | 13 |
| Repair Parts | 14 |

ATTACH ORIGINAL RECEIPT HERE FOR WARRANTY CONSIDERATION.

Flotec Limited Warranty

FLOTEC warrants to the original consumer purchaser ("Purchaser") of its products that they are free from defects in material or workmanship.

If within twelve (12) months from the date of the original consumer purchase any such product shall prove to be defective, it shall be repaired or replaced at FLOTEC's option, subject to the terms and conditions set forth below. Your dated proof of purchase will be used to determine warranty eligibility.

Exceptions to the Twelve (12) Month Warranty

Ninety (90) Day Warranty:

If within ninety (90) days from original consumer purchase any Drill Pump or In-Line Water Filter Cartridge shall prove to be defective, it shall be replaced, subject to the terms set forth below.

Three (3) Year Warranty:

If within three (3) years from original consumer purchase any 4" Submersible Well Pump shall prove to be defective, it shall be repaired or replaced at FLOTEC's option, subject to the terms set forth below.

Five (5) Year Warranty:

If within five (5) years from original consumer purchase any Pre-Charge water system tank shall prove to be defective, it shall be repaired or replaced at FLOTEC's option, subject to the terms and conditions set forth below.

General Terms and Conditions

Purchaser must pay all labor and shipping charges necessary to replace product covered by this warranty. This warranty shall not apply to acts of God, nor shall it apply to products which, in the sole

judgement of FLOTEC, have been subject to negligence, abuse, accident, misapplication, tampering, alteration; nor due to improper installation, operation, maintenance or storage; nor to other than normal application, use of service, including but not limited to, operational failures caused by corrosion, rust or other foreign materials in the system, or operation at pressures in excess of recommended maximums.

Requests for service under this warranty shall be made by returning the defective product to the Retail outlet or to FLOTEC as soon as possible after the discovery of any alleged defect. FLOTEC will subsequently take corrective action as promptly as reasonably possible. No requests for service under this warranty will be accepted if received more than 30 days after the term of the warranty.

This warranty sets forth FLOTEC's sole obligation and purchaser's exclusive remedy for defective products.

FLOTEC SHALL NOT BE LIABLE FOR ANY CONSEQUENTIAL, INCIDENTAL, OR CONTINGENT DAMAGES WHATSOEVER.

THE FOREGOING WARRANTIES ARE EXCLUSIVE AND IN LIEU OF ALL OTHER EXPRESS WARRANTIES, IMPLIED WARRANTIES, INCLUDING BUT NOT LIMITED TO THE IMPLIED WARRANTIES OF MERCHANTABILITY AND FITNESS FOR A PARTICULAR PURPOSE, SHALL NOT EXTEND BEYOND THE DURATION OF THE APPLICABLE EXPRESS WARRANTIES PROVIDED HEREIN.

Some states do not allow the exclusion or limitation of incidental or consequential damages or limitations on how long an implied warranty lasts, so the above limitations or exclusions may not apply to you. This warranty gives you specific legal rights and you may also have other rights which vary from state to state.

FLOTEC • P.O. Box 342 • Delavan, WI U.S.A. 53115

Phone: 1-800-365-6832 • Fax: 1-800-526-3757

E-Mail: flotec@flotecpump.com • Web Site: <http://www.flotecwater.com>

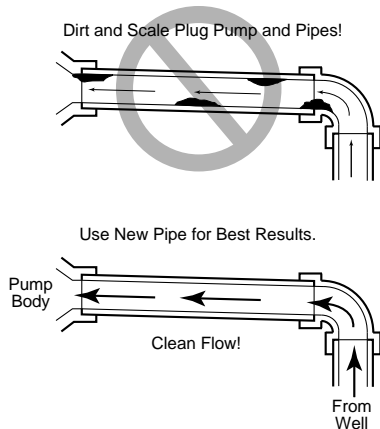

Figure 1 – No Dirt or Scale in Suction Pipe

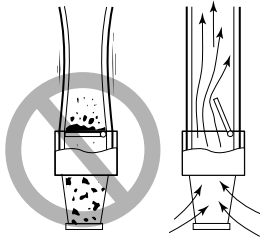

Figure 2 – Foot Valve Must Work Freely

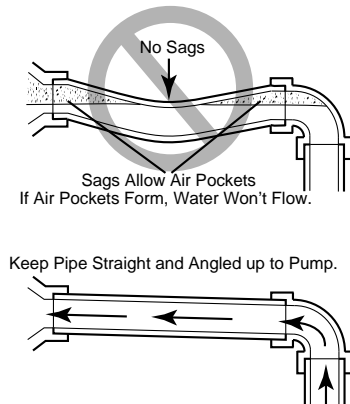

Figure 3 – No Air Pockets in Suction Pipe

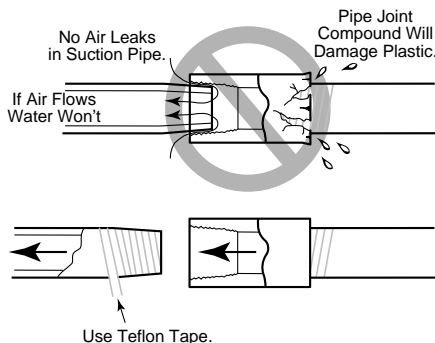

Figure 4 – Suction Pipe Must Not Leak

BEFORE YOU INSTALL YOUR PUMP

NOTICE: Pump must not be more than 20' higher than water source.

- Step 1. Long runs and many fittings increase friction and reduce flow. Locate pump as close to well as possible: use as few elbows and fittings as possible.
- Step 2. Be sure well is clear of sand. Sand will plug the pump and void the warranty.
- Step 3. Protect pump and all piping from freezing. Freezing will split pipe, damage pump and void the warranty. Check locally for frost protection requirements (usually pipe must be 12" below frost line and pump must be insulated).
- Step 4. Be sure all pipes and foot valve are clean and in good shape.
- Step 5. No air pockets in suction pipe.
- Step 6. No leaks in suction pipe. Use Teflon tape or Plasto-Joint Stik to seal pipe joints.
- Step 7. Unions installed near pump and well will aid in servicing. Leave room to use wrenches.
- Step 8. **⚠ WARNING** Pump body may explode if used as a booster pump. **DO NOT** use in a booster application.

NOTICE: Use the installation method which matches your well type.

CASED WELL INSTALLATION

- Step 1. Inspect foot valve to be sure it works freely. Inspect strainer to be sure it is clean.
- Step 2. Connect foot valve and strainer to the first length of suction pipe and lower pipe into well. Add sections of pipe as needed, using Teflon tape on male threads. Be sure that all suction pipe is leakproof or pump will lose prime and fail to pump. Install foot valve 10 to 20 feet below the lowest level to which water will drop while pump is operating (pumping water level). Your well driller can furnish this information.
- Step 3. To prevent sand and sediment from entering the pumping system, the foot valve/strainer should be at least 5 feet above the bottom of the well.
- Step 4. When the proper depth is reached, install a sanitary well seal over the pipe and in the well casing. Tighten the bolts to seal the casing.
- Step 5. When using a foot valve, a priming tee and plug as shown in Figure 5 are recommended.

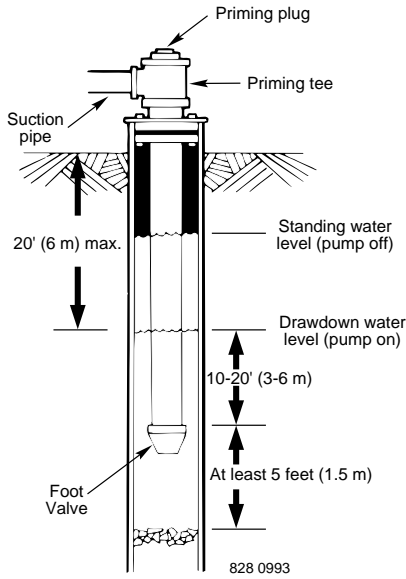

Figure 5 - Cased/Dug Well Installation

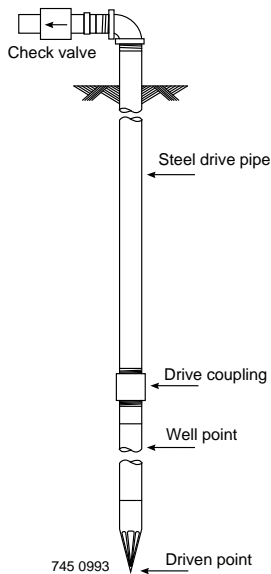

Figure 6 - Driven Point Installation

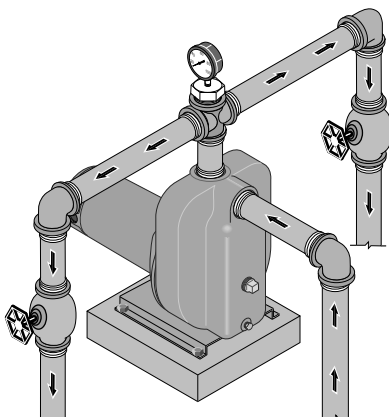

Figure 7 - Multiple Discharge

DUG WELL INSTALLATION

Same as cased well installation.

DRIVEN POINT INSTALLATION

NOTICE: More than one driven point may be needed to give adequate water flow to pump.

Step 1. Connect the suction pipe to the drive point as illustrated in Figure 6. Keep horizontal pipe run as short as possible. Use Teflon tape on male pipe threads. Multiple well points may be necessary to provide sufficient water to pump.

Step 2. Install a check valve in horizontal pipe. Flow arrow on check valve must point toward pump.

HORIZONTAL PIPING FROM WELL TO PUMP

Step 1. Never install a suction pipe that is smaller than the suction port of the pump.

Step 2. To aid priming on well point installations, install a line check valve as shown in Figure 6. Be sure check valve flow arrow points toward pump.

DISCHARGE PIPE SIZES

Step 1. If increasing discharge pipe size, install reducer in pump discharge port. Do not increase pipe size by stages.

Step 2. When the pump is set away from the points of water use, the discharge pipe size should be increased to reduce pressure losses caused by friction.

- Up to 100' run: Same size as pump discharge port.
- 100' to 300' run: Increase one pipe size.
- 300' to 600' run: Increase two pipe sizes.

LAWN SPRINKLING APPLICATION

This pump is designed for lawn sprinkling. It is designed to deliver plenty of water at full sprinkler pressure. It can pump from a pond, cistern or well points.

Pump discharge can be divided to supply two (2) or more sprinkler systems. A suggested multiple discharge to service is shown in Figure 7.

Do not use in a pressure tank or booster pump application.

Maximum running pressure is 40 PSI for model FP5242-00 and 50 PSI for model FP5252-00.

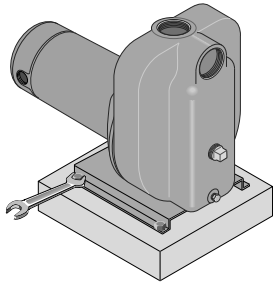

Figure 8 – Bolt Pump Down

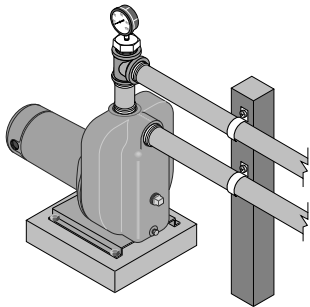

Figure 9 – Independently Support All Piping Attached to Pump

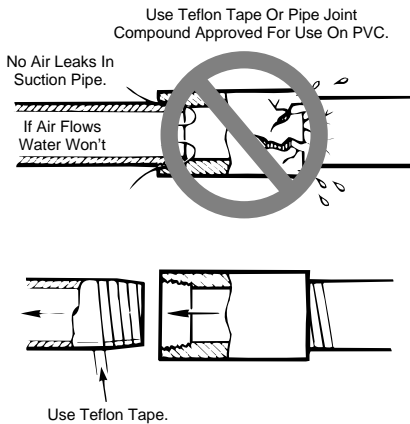

Figure 10 – Use Teflon tape or Plasto-Joint Stik on pipe joints and connections to pump

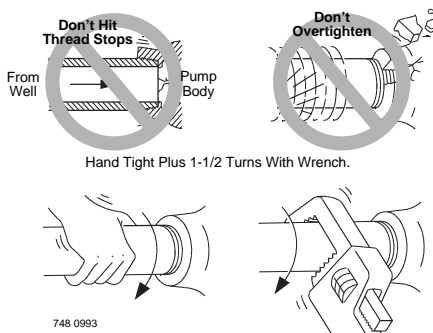

Figure 11 – Don't overtighten

PUMP INSTALLATION

NOTICE: Use only Teflon tape or Teflon based joint compounds for making all threaded connections to the pump itself. **Do not use pipe joint compounds on the pump:** they can react with the plastic in the pump components. Make sure that all pipe joints in the suction pipe are air tight as well as water tight. If the suction pipe can suck air, the pump will not be able to pull water from the well.

Step 1. Bolt pump to solid, level foundation.

Step 2. Support all piping connected to the pump.

Step 3. Wrap 1-1/2 to two layers of Teflon tape clockwise (as you face end of pipe) on all male threads being attached to pump.

Step 4. Tighten joints hand tight plus 1-1/2 turns. Do not overtighten.

NOTICE: Install pump as close to well head as possible. Long piping runs and many fittings create friction and reduce flow.

NOTICE: For long horizontal pipe runs, install a priming tee between check valve and well head as shown in Figure 5. For driven point installations, install a check valve as shown in Figure 6. Be sure check valve flow arrow points **toward** pump.

Use schedule 80 or iron pipe. See "Installation" for more information.

Connection diagram for dual voltage, single-phase motors. Your dual-voltage motor's terminal board (under the motor end cover) will match one of the diagrams below. Follow that diagram if necessary to convert motor to 115 Volt power.

Connect power supply wires to L1 and L2. For 3-phase motors, or if motor does not match these pictures, follow the connection diagram on the motor nameplate.

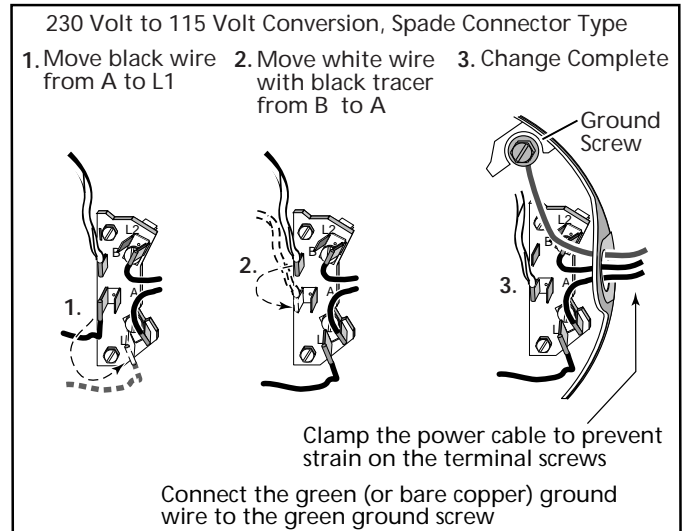
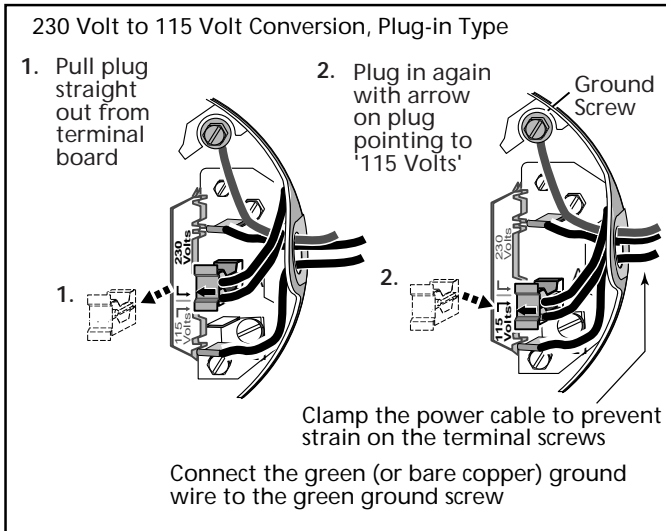

Figure 12 – 115/230V Dual Voltage Single Phase Wiring Diagram

⚠ WARNING

Hazardous voltage. Can shock, burn, or cause death.

Disconnect power to motor before working on pump or motor. Ground motor before connecting to power supply.

WIRING

- ⚠ Ground motor before connecting to electrical power supply. Failure to ground motor can cause severe or fatal electrical shock hazard.
- ⚠ Do not ground to a gas supply line.
- ⚠ To avoid dangerous or fatal electrical shock, turn OFF power to motor before working on electrical connections.
- ⚠ Supply voltage must be within $\pm 10\%$ of nameplate voltage. Incorrect voltage can cause fire or damage motor and voids warranty. If in doubt consult a licensed electrician.
- ⚠ Use wire size specified in Wiring Chart (Page 8). If possible, connect pump to a separate branch circuit with no other appliances on it.
- ⚠ Wire motor according to diagram on motor nameplate. If nameplate diagram differs from diagrams above, follow nameplate diagram.

Step 1. Install, ground, wire and maintain this pump in accordance with electrical code requirements. Consult your local building inspector for information about codes.

- Step 2. Provide a correctly fused disconnect switch for protection while working on motor. Consult local or national electrical codes for switch requirements.
- Step 3. Disconnect power before servicing motor or pump. If the disconnect switch is out of sight of pump, lock it open and tag it to prevent unexpected power application.
- Step 4. Ground the pump permanently using a wire of the same size as that specified in wiring chart, below. Make ground connection to green grounding terminal under motor canopy marked GRD. or ⊕.
- Step 5. Connect ground wire to a grounded lead in the service panel or to a metal underground water pipe or well casing at least 10 feet long. Do not connect to plastic pipe or insulated fittings.
- Step 6. Protect current carrying and grounding conductors from cuts, grease, heat, oil, and chemicals.
- Step 7. Connect current carrying conductors to terminals L1 and L2 under motor canopy. When replacing motor, check wiring diagram on motor nameplate against Figure 12. If the motor wiring diagram does not match either diagram in Figure 12, follow the diagram on the motor.

IMPORTANT: 115/230 Volt single phase models are shipped from factory with motor wired for 230 volts. If power supply is 115 volts, remove motor canopy and reconnect motor as shown in Figure 12. Do not try to run motor as received on 115 volt current.

- Step 8. Motor has automatic internal thermal overload protection. If motor has stopped for unknown reasons, thermal overload may restart it unexpectedly, which could cause injury or property damage. Disconnect power before servicing motor.
- Step 9. If this procedure or the wiring diagrams are confusing, consult a licensed electrician.

You have just completed the wiring for your pump.

Please go to Page 9 for startup preparations.

Wiring Chart – Recommended Wire and Fuse Sizes

| Pump Model | HP | Max. Load Amps (115V/230V) | Volts/ Hertz/Phase | Branch Fuse Rating Amps* (115V/230V) | DISTANCE IN FEET FROM MOTOR TO SUPPLY | | | |
|------------|-------|----------------------------|--------------------|--------------------------------------|--|---------------|--------------|------------|
| | | | | | 0 - 50 | 51 - 100 | 101 - 200 | 201 - 300 |
| | | | | | AWG WIRE SIZE - 115V/230V (mm ²) | | | |
| FP5242-00 | 1-1/2 | 19.2/9.6 | 115/230/60/1 | 25/15 | 10/14 (5.5/2) | 10/14 (5.5/2) | 8/14 (8.4/2) | 6/12 (9/3) |
| FP5252-00 | 2 | 12 | 230/60/1 | 15 | 14 (2) | 14 (2) | 14 (2) | 12 (3) |

*Dual element or Fusetron time delay fuses recommended for all motor circuits.

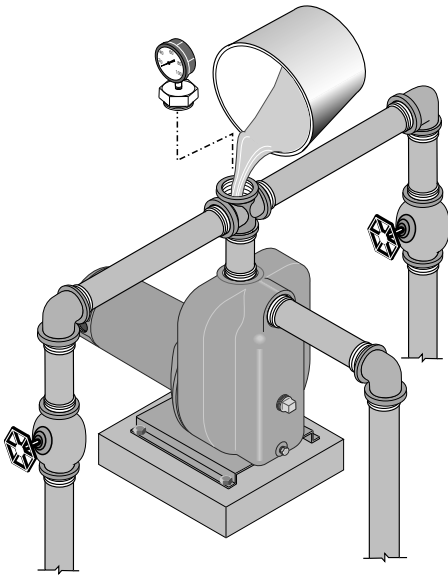

Figure 13 – Remove Priming Plug. Fill Pump Before Starting

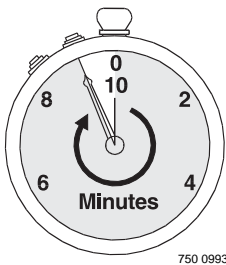

Figure 14 – Run Ten Minutes or Less

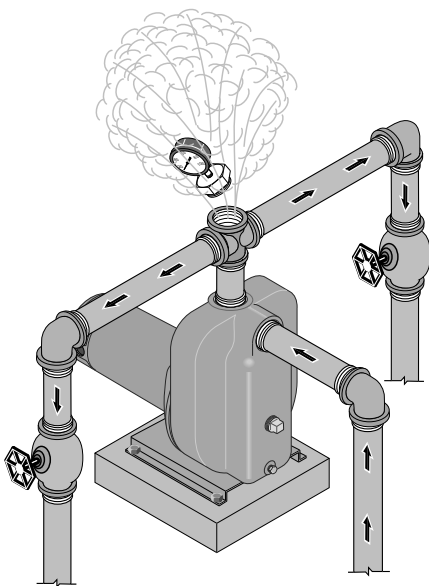

Figure 15 – Do Not Run Pump with Discharge Shut-off

PRIMING THE PUMP

NOTICE: ‘Priming’ refers to the pump expelling all air in the system and beginning to move water from its source out into the system. It does not refer only to pouring water into the pump (although pouring water in is usually the first step).

NOTICE: NEVER run pump dry. Running pump without water in it will damage seals and can melt impeller and diffuser. To prevent damage, **fill pump with water before starting.**

- Step 1. Remove priming plug (Figure 13). Replacing the priming plug with a reducer bushing with a pressure gauge mounted in it will make troubleshooting pump performance easier.
- Step 2. Make sure suction and discharge valves and any hoses on discharge side of pump are open.
- Step 3. Fill pump and suction pipe with water (Figure 13).
- Step 4. Replace priming plug, using Teflon tape on thread; tighten plug.

NOTICE: If a priming tee and plug have been provided for a long horizontal run, be sure to fill suction pipe through this tee and replace plug. (Don’t forget to Teflon tape the plug.)
- Step 5. Start pump: water should be produced in 10 minutes or less, the time depending on depth to water (not more than 20’) and length of horizontal run (10’ of horizontal suction pipe = 1’ of vertical lift due to friction losses in the pipe) (Figure 14).

If no water is produced within 10 minutes, stop pump, release all pressure, remove priming plug, refill and try again.

▲ WARNING Hazardous pressure and risk of explosion and scalding. If pump is run continuously at no flow (that is, with discharge shut off or without priming), water may boil in pump and piping system. Under steam pressure, pipes may rupture, blow off of fittings or blow out of pump ports and scald anyone near.

To prevent explosion, do the following:

- Step A. Be sure discharge (valve, pistol grip hose nozzle, etc.) is open whenever pump is running.
- Step B. If pump fails to produce water when attempting to prime, stop pump, release all pressure, drain pump and refill with cold water after every two attempts.
- Step C. When priming, monitor pump and piping temperature. If pump or piping begin to feel warm to the touch, shut off pump and allow system to cool off. Release all pressure in system and refill pump and piping with cold water.

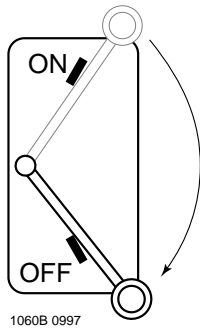

Figure 16 – Disconnect Power

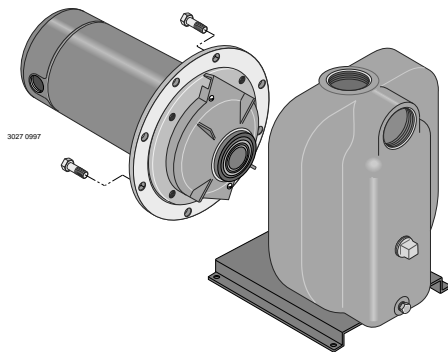

Figure 17 – Slide Motor Back

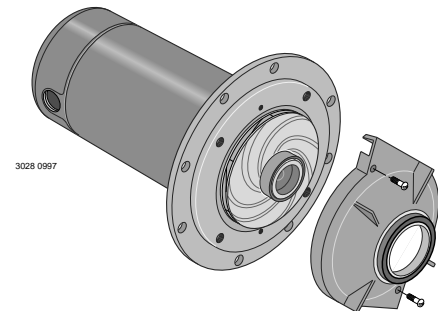

Figure 18 – Remove Diffuser

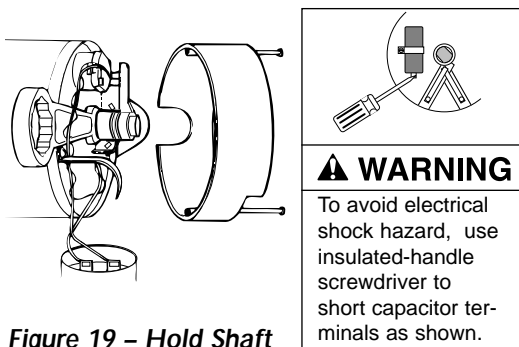

Figure 19 – Hold Shaft

MAINTENANCE

Pump and piping need not be disconnected to repair or replace motor or seal. If motor is replaced, replace the shaft seal (Key No. 7, Page 14). Keep one on hand for future use.

Be sure to prime pump before starting.

NOTICE: Check motor label for lubrication instructions. The mechanical shaft seal in the pump is water lubricated and self-adjusting.

NOTICE: Drain pump when disconnecting from service or when it might freeze.

PUMP DISASSEMBLY

Step 1. Disconnect power to motor (Figure 16).

NOTICE: Mark wires for correct assembly.

Step 2. Release all water pressure from system.

Step 3. Remove drain plug and drain pump.

Step 4. Remove capscrews holding seal plate to pump body. Motor assembly and seal plate can now be pulled away from pump body (Figure 17). CAREFULLY remove gasket.

CLEANING/REPLACING IMPELLER

NOTICE: First, follow instructions under “Pump Disassembly”.

Step 1. Remove screws fastening diffuser to seal plate; remove diffuser (see Figure 18). Exposed impeller can now be cleaned.

Step 2. If impeller must be replaced, loosen two machine screws and remove motor canopy (see Figure 19).

Step 3. **⚠ WARNING** Capacitor voltage may be hazardous. To discharge capacitor, hold insulated handle screwdriver **BY THE HANDLE** and short capacitor terminals together (see Figure 19). Do not touch metal screwdriver blade or capacitor terminals. If in doubt, consult a qualified electrician.

Step 4. Unscrew capacitor clamp and remove capacitor. Do not disconnect capacitor wires to motor.

Step 5. Slide 7/16" open end wrench in behind spring loaded switch on motor end of shaft; hold motor shaft with wrench on shaft flats and unscrew impeller screw (if used) by turning clockwise (**left hand thread**) when looking into eye of impeller.

Step 6. Unscrew impeller while holding shaft by turning **counterclockwise** while looking into eye of impeller.

Step 7. To reinstall, reverse steps 1 through 6.

Step 8. See directions under “Pump Reassembly,” Page 12.

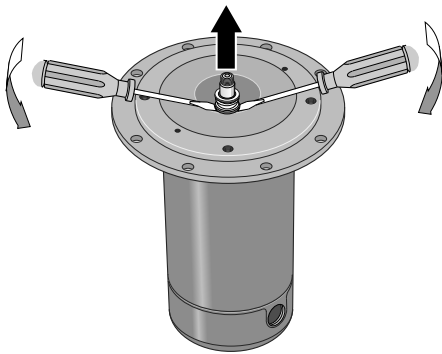

Figure 20 – Remove Seal plate

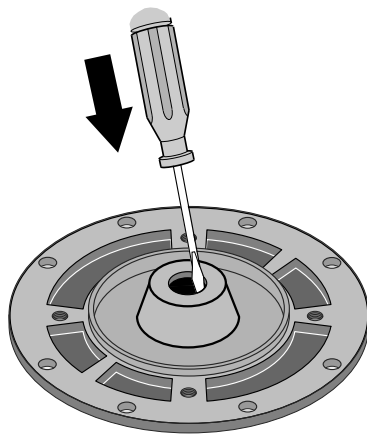

Figure 21 – Tap Out Seal

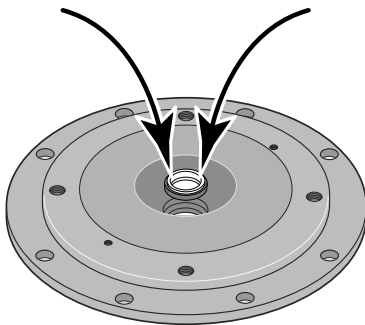

Figure 22 – Press in New Seal

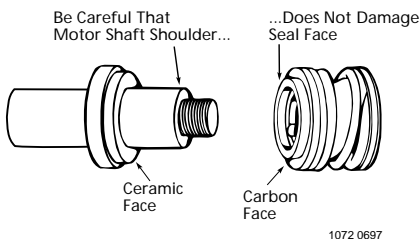

Figure 23 – Protect Seal Faces

REMOVING OLD SEAL

- Step 1. Follow instructions under “Pump Disassembly”.
- Step 2. Follow steps 2 through 5 under “Cleaning/Replacing Impeller”.
- Step 3. Remove rotating half of seal by placing two screwdrivers under seal ring and **carefully** prying up (Figure 20).
- Step 4. Remove nuts from studs holding seal plate to motor. Carefully slide seal plate off of shaft.

NOTICE: Be sure you do not scratch or mar shaft; if shaft is marred, it must be dressed smooth with fine emery or crocus cloth before installing new seal. **DO NOT** reduce shaft diameter!
- Step 5. Place seal plate half face down on flat surface and tap out stationary half of seal (see Figure 21).

INSTALLING NEW SEAL

- Step 1. Clean seal cavity in seal plate.
- Step 2. Wet outer edge of Rubber Cup on ceramic seat with liquid soap. Be sparing!
- Step 3. Put clean cardboard washer on seal face. With thumb pressure, press ceramic seal half firmly and squarely into seal cavity in copper heat sink (See Figure 22). Polished face of ceramic seat is up. If seal will not seat correctly, remove, placing seal **face up** on bench. Reclean cavity. Seal should now seat correctly.
- Step 4. If seal does not seat correctly after recleaning cavity, place a cardboard washer over polished seal face and **carefully** press into place using a piece of standard 3/4" pipe as a press.

NOTICE: Be sure you do not scratch seal face.
- Step 5. Dispose of cardboard washer and recheck seal face to be sure it is free of dirt, foreign particles, scratches and grease.
- Step 6. Inspect shaft to be sure it is free of nicks and scratches.
- Step 7. Reassemble pump body half to motor flange. **BE SURE** it is right side up.
- Step 8. Apply liquid soap sparingly (one drop is sufficient) to inside diameter of rotating seal member.
- Step 9. Slide rotating seal member (carbon face first) onto shaft until rubber drive ring hits shaft shoulder (Figure 23).

NOTICE: Be sure not to nick or scratch carbon face of seal when passing it over threaded shaft end or shaft shoulder. The carbon surface must remain clean or short seal life will result.

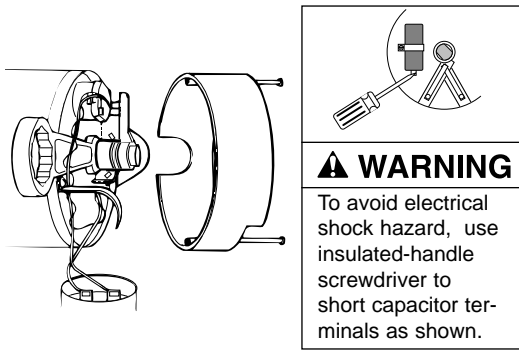

Figure 24 – Hold Shaft

Step 10. Hold motor shaft with 7/16" open end wrench on shaft flats (Figure 24) and screw impeller onto shaft. **Be sure you do not touch capacitor terminals with body or any metal object.** Tightening impeller will automatically locate seal in correct position.

Step 11. Replace impeller screw (if used) by turning counterclockwise (left-hand thread) into end of shaft.

Step 12. Remount diffuser on seal plate with two screws.

Step 13. Follow instructions under "Pump Reassembly".

PUMP REASSEMBLY

Step 1. Clean gasket surfaces on pump body and seal plate; install new gasket.

Step 2. Slide motor/seal plate assembly into pump body. Secure with capscrews (Figure 25).

Step 3. Replace base mounting bolts.

Step 4. Replace motor wiring; replace drain plug.

Step 5. Prime pump according to instructions. See "Operation."

Step 6. Check for leaks.

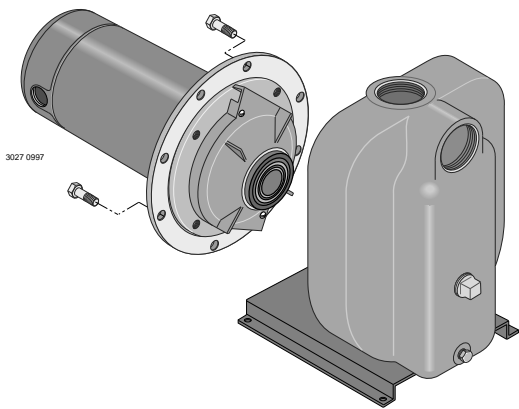
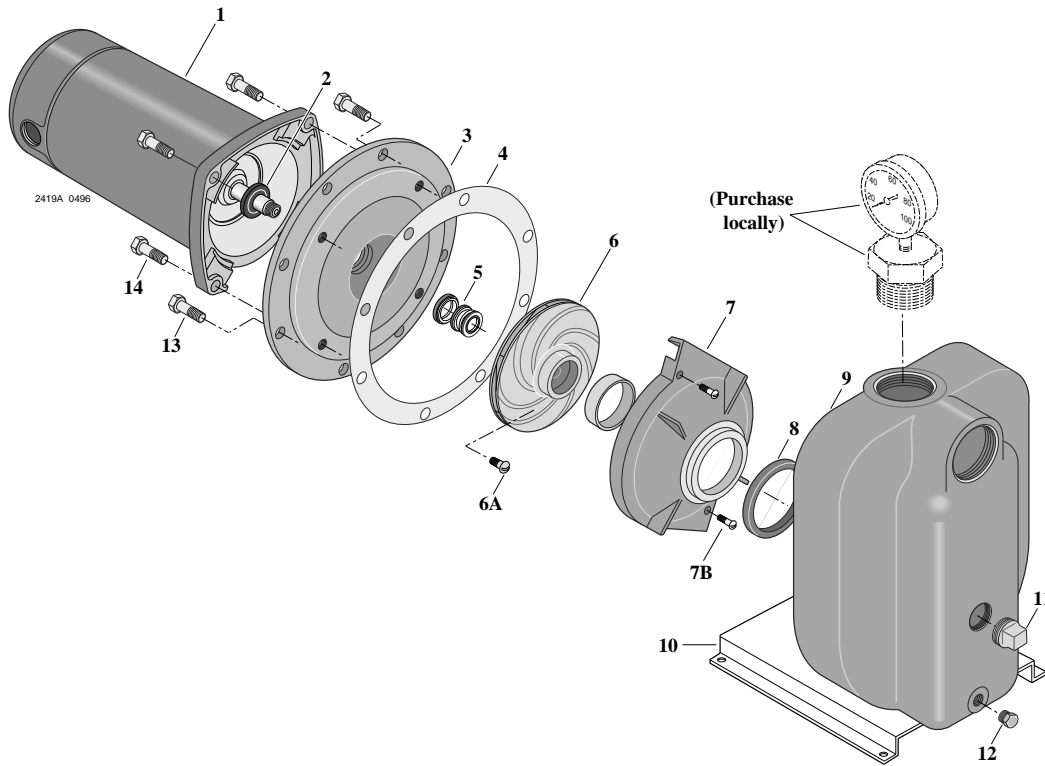

Figure 25 – Assemble Pump

| SYMPTOM | POSSIBLE CAUSE(S) | CORRECTIVE ACTION |
|---|--|---|
| Motor will not run | Disconnect switch is off Fuse is blown or circuit breaker tripped Starting switch is defective Wires at motor are loose, disconnected, or wired incorrectly | Be sure switch is on Replace fuse or reset circuit breaker DISCONNECT POWER; Replace starting switch Refer to instructions on wiring (Pages 7 and 8). DISCONNECT POWER; check and tighten all wiring. ⚠ WARNING Capacitor voltage may be hazardous. To discharge capacitor, hold insulated handle screwdriver BY THE HANDLE and short capacitor terminals together. Do not touch metal screwdriver blade or capacitor terminals. If in doubt, consult a qualified electrician. |
| Motor runs hot and overload kicks off | Motor is wired incorrectly Voltage is too low Pump cycles too frequently | Refer to instructions on wiring Check with power company. Install heavier wiring if wire size is too small (See Electrical / Wiring Chart). See section below on too frequent cycling |
| Motor runs but no water is delivered* * (Note: <i>Stop pump</i> ; then check prime before looking for other causes. Unscrew priming plug and see if water is in priming hole). | Pump in new installation did not pick up prime through: 1. Improper priming 2. Air leaks 3. Leaking foot valve or check valve Pump has lost prime through: 1. Air leaks 2. Water level below suction pipe inlet Foot valve or strainer is plugged Ejector or impeller is plugged Check valve or foot valve is stuck shut Pipes are frozen Foot valve and/or strainer are buried in sand or mud Water level is too low for centrifugal setup to deliver water | In new installation: 1. Re-prime according to instructions 2. Check all connections on suction line 3. Replace foot valve or check valve In installation already in use: 1. Check all connections on suction line and shaft seal 2. Lower suction line into water and re-prime. If water level in well exceeds 20 feet, a deep well pump is needed. Clean foot valve or strainer Clean impeller Replace check valve or foot valve Thaw pipes. Bury pipes below frost line. Heat pit or pump house. Raise foot valve and/or strainer above bottom of water source. Clean foot valve and strainer. A deep well jet pump and package may be needed (over 20 ft. to water) to deliver water to full capacity |
| Pump does not deliver water to full capacity | Water level in deep well is lower than estimated Steel piping (if used) is corroded or limed, causing excess friction Piping is too small in size Air leak in suction line Need more driven points | A deep well jet pump and package may be needed (over 20 ft. to water) to deliver water to full capacity Replace with plastic pipe where possible, otherwise with new steel pipe Use larger piping Check all connections, inspect line for cracks (test with soapy water while pump is running - a leak will pull soap suds into hole) Add driven points to suction line until performance in O.K. |



| Key No. | Part Description | MODEL NUMBER | |
|---------|---------------------------------|-----------------------|-------------------|
| | | FP5242-00 1-1/2 HP | FP5252-00 2 HP |
| 1 | Motor, 115/230V, 1 Phase | A100FLL | — |
| 1 | Motor, 230V, 1 Phase | — | A100GSLL |
| 2 | Water Slinger | C69-2 | C69-2 |
| 3 | Seal Plate | C3-155 | C3-117 |
| 4 | Gasket - Seal Plate | C20-86 | C20-87 |
| 5 | Shaft Seal | U109-6A | U109-6A |
| 6 | Impeller | C105-92PCB | C105-214PDA |
| 6A | Impeller Screw (1 Phase) | — | C30-14SS |
| 7 | Diffuser | C101-276P | C101-182 |
| 7B | Screw 1/4-20 x1" Lg. (2) | U30-696SS | — |
| 7B | Machine screw 8-32x7/8" Lg. (2) | — | U30-53SS |
| 8 | Diffuser Ring | C21-10 | C21-2 |
| 9 | Pump Body Assembly | C176-49B | C76-50 |
| 10 | Base | U4-5 | U4-5 |
| 11 | Pipe Plug 3/4" NPT - Sq. Hd. | U78-60S | U78-60S |
| 12 | Plug 1/4" NPT Hex. Hd. | U78-941ZPV | U78-941ZPV |
| 13 | Capscrew 3/8-16x3/4" Lg. (6) | U30-72ZP | — |
| 13 | Capscrew 5/16-18x3/4" Lg. (8) | — | U30-60ZP |
| 14 | 3/8-16x1" Capscrew (4) | U30-74ZP | U30-74ZP |
| | • Lockwasher 3/8" (4) | — | — |
| | • Lockwasher - 3/8" (2) | U43-12ZP | U43-12ZP |
| | • Capscrew 3/8-16x5/8" Lg. (2) | U30-71ZP | U30-71ZP |

• Not illustrated NOTE: Quantity is one unless otherwise noted ().