

# The G57 Two-Pump and Four-Pump Systems Deliver Flows Up To 20 GPM.

## FLOJET

Flojet's ultra-efficient, "stand-up-to-anything" G57 pump has become an industry leader. And now Flojet has raised the bar on pump performance even higher with the G57 Two-Pump and Four-Pump system. The Two-Pump system delivers flows of up to 10 GPM, while the Four-Pump system delivers a 20 GPM flow.

The G57 Two and Four-Pump systems are ideal for a host of heavy-duty industrial applications. These air-operated pumps are fitted with Santoprene® or Viton® elastomers to handle even the harshest cleaners and solvents. A patented ceramic shuttle valve ensures a lifetime of stall-free operation.

Flojet's commitment to sophisticated engineering and advanced design means you can depend on these pumps to consistently, reliably deliver the highest in performance with minimal servicing, saving you time and money.

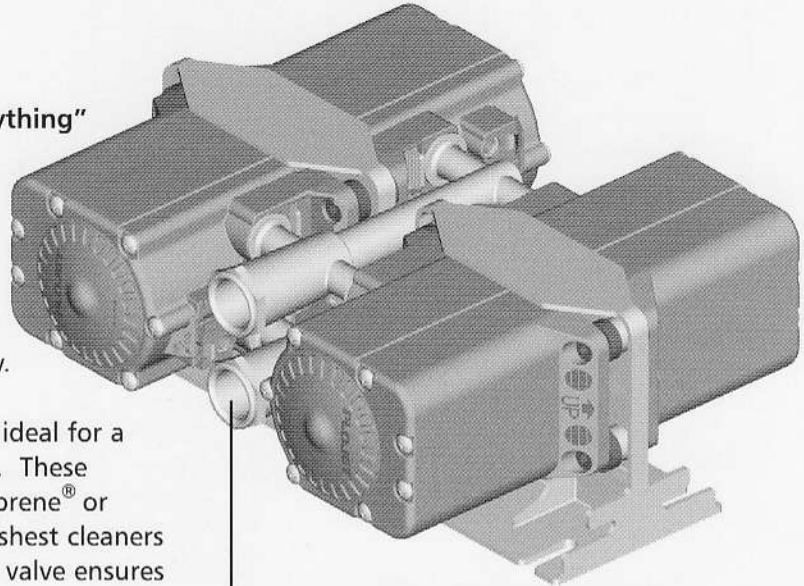

**Four-Pump manifold system** has large 3/4" NPT threaded port connections for increased flow volumes and rates.

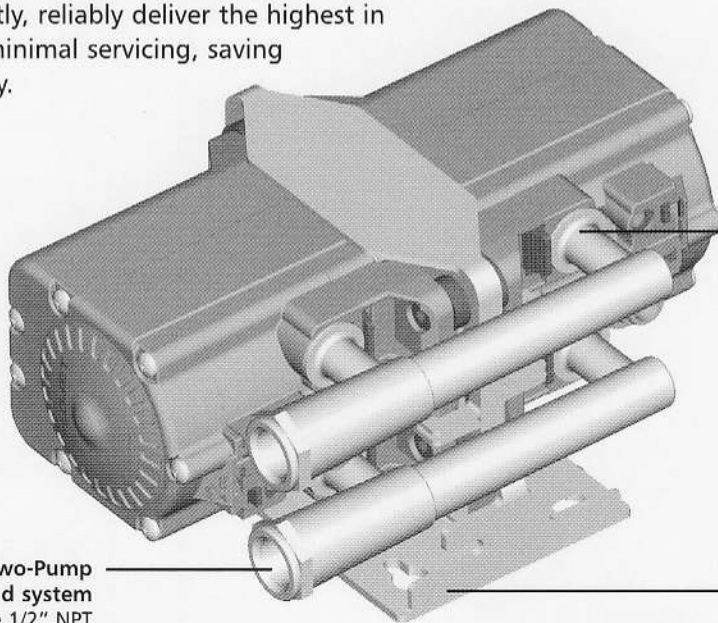

**Two-Pump manifold system** has large 1/2" NPT threaded port connections for increased flow volumes and rates.

**Snap in, snap out:** Quick release manifold fittings make change out simple, quick, and easy to perform.

**Performance wherever you need it:** Innovative mounting hardware means pumps can be fitted almost anywhere. Mounted vertically or horizontally, the system is nearly effortless to install.

**FOR MORE INFORMATION  
CONTACT THE FLOJET  
INDUSTRIAL DIVISION:  
CALL 1 800 235 6538.**

Flojet



ITT Industries