

INSTALLATION & SERVICE INFORMATION

DESCRIPTION

FLOJET Industrial Triplex Low Pressure Series pumps are designed for a wide range of applications and are constructed from a selection of materials suitable for handling a broad range of chemicals. The Triplex Low Pressure diaphragm pumps are self-priming and can run dry without harm. They are intended for intermittent duty cycles but can be run continuously for short periods of time. The higher the duty cycle, the shorter the expected life of the pump.

Typical pump uses are liquid transfer, spraying, cooling, circulation, filtration and dispensing.

CAUTION (115 Volt AC) UL recognition is based on tests with water OPERATION

To start and prime the pump, the discharge line must be opened to allow trapped air to escape, thus avoiding the potential of airlock. The pressure switch will shut off the pump automatically when the discharge valve is closed and the pressure has risen to the switch OFF set point. The pressure switch will restart the pump when a valve is opened and the discharge line pressure drops to the ON set point of the pressure switch.

DEMAND OPERATION (intermittent duty)

Demand Operation is considered an "intermittent duty" application. The maximum intermittent duty cycle is that which will cause the motor to reach its maximum thermal limits. Once the maximum thermal limit is reached, the motor must be allowed to settle to a lower (ideally ambient) temperature, before resuming operation. Running the pump at or near the maximum thermal limit for an extended period of time will shorten the life of the pump and may result in immediate pump failure.

BYPASS OPERATION (if equipped)

Models equipped with an external bypass system are designed to pump at high pressures while at low or high flow rates. Models equipped with a bypass will continue to run until the power is manually turned off.

The Triplex Low Pressure pumps are not recommended for continuous duty service due to limited motor brush life. Operation at lower pressures and temperatures, however, will extend overall pump service life.

MOUNTING

The FLOJET Triplex Low Pressure Series pumps are self-priming. Vertical prime may vary depending on the fluid viscosity, suction tube size, foot valve and pump configuration. The pump should be mounted in a dry and adequately ventilated area. If mounted within an enclosure, provisions to cool the motor may be necessary.

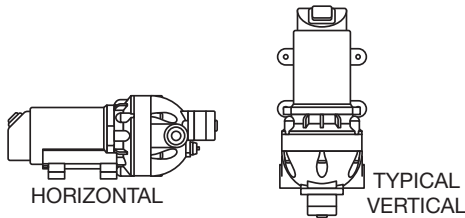

PREVENTATIVE MAINTENANCE TIPS

If pumping a liquid other than water, the pump should be flushed with water (if applicable) after each use.

Sealers and Teflon tape acting as a lubricant can cause cracked housings or stripped threads due to over tightening. Care should be used when applying sealers; the tape may enter the pump, thus inhibiting valve action, causing no prime or no shut-off conditions. Failures due to foreign debris are not covered under warranty.

Before freezing conditions occur, the pump must be liquid free or winterized with proper anti-freezing chemicals.

DIMENSIONAL DRAWING

Inches (Millimeters)
Dimensional tolerances
± 0.06 inches
Consult factory if precise
details are required.

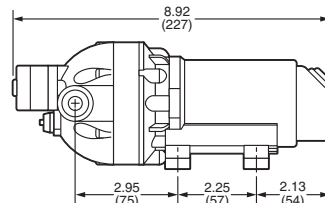
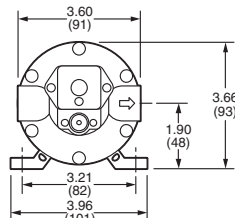

If mounting the pump in an outdoor environment, the pump should be shielded from water, dust, sunlight and washdown spray.

Do not assume chemical compatibility. If the fluid is improperly matched to the pump's elastomers, the pump may fail to prime, have low pressures, or the pressure switch may not shut off.

PLUMBING

Use flexible hose with the correct pressure rating that is compatible with the fluid to be pumped. Tubing should be a minimum of 3/8" (9.5 mm) ID and at least 20 inches (508 mm) in length to avoid excess stress on the pump ports. Do not crimp or kink the tubing. The pump head may be rotated in 120° increments. Or reverse the flow (180°) by using other optional lower housing to simplify plumbing.

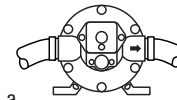

FLEXIBLE HOSE

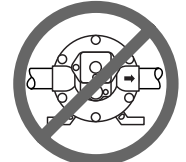

RIGID PIPE

FLOJET does not recommend the use of metal fittings; standard plastic male and female threaded fittings can be acquired at commercial plumbing supply stores. FLOJET also distributes plastic barb fittings through our distributors (form no. F100-001). The use of check valves in the plumbing system could interfere with the priming ability of the pump. If a check valve is installed in the plumbing, it must have a cracking pressure of no more than 2 PSI (.14 bar).

Use of a minimum 40-mesh strainer or filter in the pump inlet line will prevent foreign debris from entering the system. Failures due to foreign debris entering the pump will not be covered under the limited warranty.

Note: Inlet pressure must not exceed 30-PSI (2.1 bar) maximum.



WARNING



Risk of an electrical shock!

When wiring electrically driven pumps, follow all electrical and safety codes, as well as the most recent National Electrical Code (NEC) and Occupational Safety and Health Act (OSHA).

Make certain the power source conforms to the pump voltage. Be sure all power is disconnected before installation.

The pump should be wired into an individual (dedicated) circuit, controlled with an UL/C-UL certified double pole switch rated at or above the fuse ampere indicated on the pump motor label.

On 115-volt AC pumps, the black wire lead is live or common, the white lead wire is neutral and the green/yellow is ground. On 230-volt AC pumps the brown wire lead is live or common, the blue wire is neutral and the green/yellow is ground.

On 12 and 24 volt pumps the red lead is positive and should be connected to the battery plus (+) terminal. The black lead is ground and should be connected to the battery minus (-) terminal. Use T6 AWG wire minimum. Use a fuse to protect the system wiring and components.

Improper duty cycle and/or rapid start/stop conditions caused by undersized spray nozzles will cause the internal thermal breaker (if equipped) to trip, or can cause premature motor failure due to excessive heat.



WARNING



DO NOT USE TO PUMP FLAMMABLE FLUIDS, GASOLINE, KEROSENE FUEL OIL, ETC. DO NOT USE PUMP IN A EXPLOSIVE ENVIRONMENT.

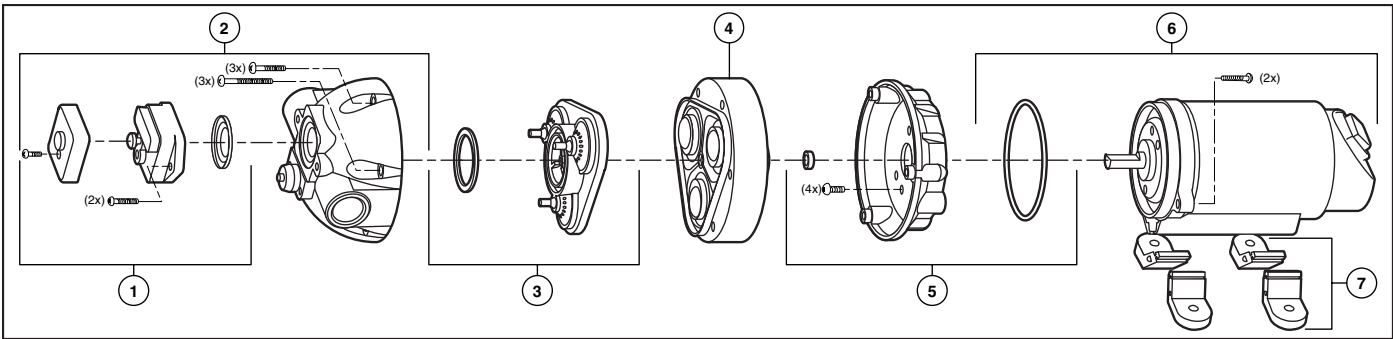

KEY	DESCRIPTION	KEY	DESCRIPTION
1	Pressure Switch Assembly	5	Front End Bell Assembly
2	Upper Housing with Switch	6	Motor Assembly
3	Check Valve Assembly with O-Ring	7	Mounting Feet
4	Diaphragm/Lower Housing Assembly		

DISASSEMBLE

Pump Housing (2)

1. Disconnect power to the pump motor.
2. Remove the pressure switch cover (1) and remove the two wire leads from the switch spade connectors.
3. Remove the six screws from the upper housing (2).
4. Remove the upper housing from the check valve and diaphragm/lower housing assemblies (3 & 4).

Check Valve Assembly (3) (To replace check valve only follow steps 1 through 6)

5. The check valve housing and O-ring (3) are located on the diaphragm/lower housing assembly (4).
6. Remove the check valve (3) from the diaphragm/lower housing assembly (4) (pull valve body from the diaphragm).

Diaphragm/Cam/Lower Housing Assembly (4).

7. Remove the diaphragm/lower housing assembly (4) from the motor front end bell adapter (5).

Motor Replacement (6)

8. To replace the motor only, follow steps 1 through 7.
9. Remove the front end bell assembly (5) from the old motor (you will require a 3mm Allen wrench).
10. Remove the four Allen head screws from the motor adapter and remove the adapter and O-ring.

TROUBLESHOOTING

Failure to prime - motor operates, but no pump discharge

- Restricted intake or discharge line. Open all line valves, check for "jammed" check valves, and clean clogged lines.
- Air leak in intake line.
- Punctured pump diaphragm.
- Defective pump check valve.
- Crack in pump housing.
- Debris in check valves.

Motor fails to turn on

- Pump or equipment not plugged in electrically.
- Loose wiring connection.
- Pressure switch failure.
- Defective motor or rectifier.
- Frozen cam/bearing.

Pump fails to turn off after discharge valves are closed

- Depletion of available liquid supply.
- Punctured pump diaphragm.
- Discharge line leak.
- Defective pressure switch.
- Insufficient voltage to pump.
- Debris in check valves.

Low flow and pressure

- Air leak at pump intake.
- Accumulation of debris inside pump and plumbing.
- Worn pump bearing (excessive noise).
- Punctured pump diaphragm.
- Defective rectifier or motor.
- Insufficient voltage to pump.

Pulsating flow - pump cycling on and off

- Restricted pump delivery. Check discharge lines, fittings, valves and spray nozzles for clogging or undersizing.

REASSEMBLY

Pressure Switch Assembly (1)

1. Install the switch diaphragm into upper housing. Note: Check the old diaphragm for the material mark located in the center of the new diaphragms. V is for VITON, B is for BUNA, and E is for EPDM. Select the correct material for the installation.
2. Install the switch body over the diaphragm, align the screw holes and install the two mounting screws.
3. Reinstall the two wires onto the spade connectors, then install the switch cover and screw.

Check Valve Assembly (3)

4. Install the O-ring into the O-ring groove located on the discharge side of the check valve assembly (3).
5. Install the check valve assembly into the diaphragm (4) aligning the check valve body with the diaphragm seal walls (push in to secure to the diaphragm).

Upper Housing Assembly (2)

6. With the check valve assembly installed on the diaphragm, place the upper housing assembly onto the pre-assembled lower housing diaphragm/cam assembly (4).
7. Align the cam with the motor "D" shaft and slide the cam and pump head assembly onto the motor shaft (6) (lube the motor shaft with a small amount of light grease).
8. Check the discharge location (see arrow on front of port) for correct port orientation (discharge right is the standard position).
9. Install the six pump head screws through the upper housing and through the lower housing into the front end bell assembly (2, 4, & 5) aligning the three pins on the motor adapter with the upper housing and tighten securely (torque to 25 inch-pounds).

Motor Assembly (6)

10. Install the O-ring into the front end bell assembly (5).
11. Install the front end bell assembly onto the new motor by aligning the adapter with the motor housing and screw bosses (6).
12. Install the four (3mm) Allen screws through the adapter and into the motor and secure (5 & 6). (Apply a thin layer of screw Loctite 271 to secure these screws.)
13. Install the pump head by following steps 6 through 9.

PRODUCT WARRANTY

Flojet warrants this product to be free of defects in material and/or workmanship for a period of one year after purchase by the customer from Flojet. During this one year warranty period, Flojet will, at its option and at no charge to the customer, repair or replace this product if found defective. No product will be accepted for return without a return material authorization number. All return goods must be shipped with transportation charges prepaid. This is only a summary of our Limited Warranty. For a copy of our complete warranty, please request Form No. 100-101.

RETURN PROCEDURE

Prior to returning any product to Flojet, call customer service for an authorization number. This number must be written on the outside of the shipping package. Place a note inside the package with an explanation for return as well as the authorization number. Include your name, address and phone number.

SERVICE KITS

Kits are readily available to repair standard Triplex Low Pressure Series pumps. To insure that the correct kits are received, the model number and all name plate data must be included with the order. Contact a FLOJET distributor to order the necessary repair kits.

Flojet



U.S.A.
Flojet
20 Icon
Foothill Ranch, CA 92610-3000
Tel: (949) 859-4945
Fax: (949) 859-1153

UNITED KINGDOM
Jabsco/Flojet
Bingley Road, Hoddesdon
Hertfordshire EN11 0BU
Tel: +44 (0) 1992 450145
Fax: +44 (0) 1992 467132

CANADA
Fluid Products Canada
55 Royal Road
Guelph, Ontario N1H 1T1
Tel: (519) 821-1900
Fax: (519) 821-2569

JAPAN
NHK Jabsco Company Ltd.
3-21-10, Shin-Yokohama
Kohoku-Ku, Yokohama, 222
Tel: 045-475-8906
Fax: 045-475-8908

GERMANY
Jabsco GmbH
Oststrasse 28
22844 Norderstedt
Tel: +49-40-53 53 73-0
Fax: +49-40-53 53 73-11