

SENSOR VSD™ WATER SYSTEM

FEATURES

- Variable Speed Control
- Solid State Pressure Sensor
- Nearly Silent Operation / No Cycling
- Operates on 12Vdc or 24Vdc
- Controls Pressure by Changing Motor Speed
- Speeds Up As Demand Increases
- Self-priming / Runs Dry
- No Accumulator Tank Needed
- CSA Listed / EN ISO 8846 Marine / C.E. Certified
- Protected under U.S. Patent #6,607,360
- Includes Inlet Strainer

SPECIFICATIONS

Motor: Permanent magnet, double ball bearing armature. Electronic speed control built into rear endbell.

Pump: Four chamber positive displacement diaphragm design. Self-priming up to 10 feet suction lift. Pump able to run dry without damage. Removable port adapters.



Models R4515-743 & R4525-743

AUTOMATIC VARIABLE SPEED MOTOR DRIVEN

Pump Series	Dimensions - Inches (mm)			Weight lb. (kg)
	Height	Width	Length	
R4515-743	3.75 (95)	6.3 (160)	9.0 (221)	4.3 (2)
R4525-743	3.75 (95)	6.3 (160)	10.3 (252)	6.3 (3)

Model	Volts	Amp Draw (24V)	Max Fuse	Flow GPM (LPM)	Sensor Pressure	Cut-out Pressure	Inlet Strainer
R4515-743	12-24Vdc	8.0 (4.0)	15A	3.7 (13.5)	25 (1.7 bar)	35 psi (2.4 bar)	Yes
R4525-743	12-24Vdc	12.0 (6.0)	15A	4.5 (16.3)	30 (2.1 bar)	40 psi (2.8 bar)	Yes

OPERATION

Mount the pump in a dry, ventilated location. The inlet strainer must be installed between the fresh water supply and the pump inlet port. The supply tank should be at least half full prior to initial operation.

NOTE: The VSD electronics require a battery installed in the DC power supply when using an AC to DC converter or battery charging system.

IMPORTANT: Polarity of electrical connections is very important. Insure that the RED (+) motor lead is

connected to a fused positive d.c. circuit. The BLACK (-) motor lead must be connected to the negative DC circuit. In the event that polarity is reversed, the in-line fuse must be replaced.

To prime the plumbing system, open all the faucets and turn on the power to the pump. Shut off each faucet as it begins to run free of air. As the last faucet is closed the pump will slow down and shut off.

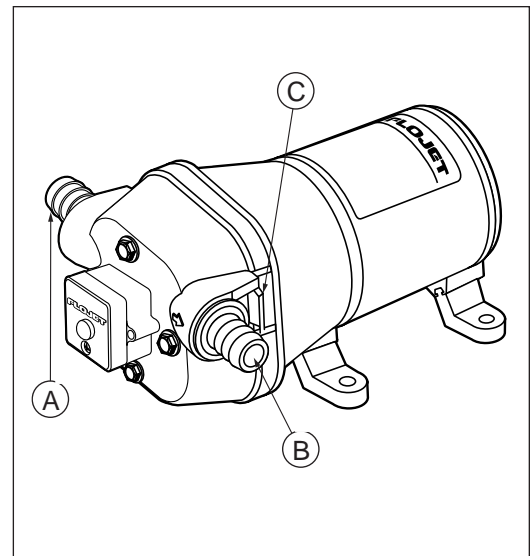
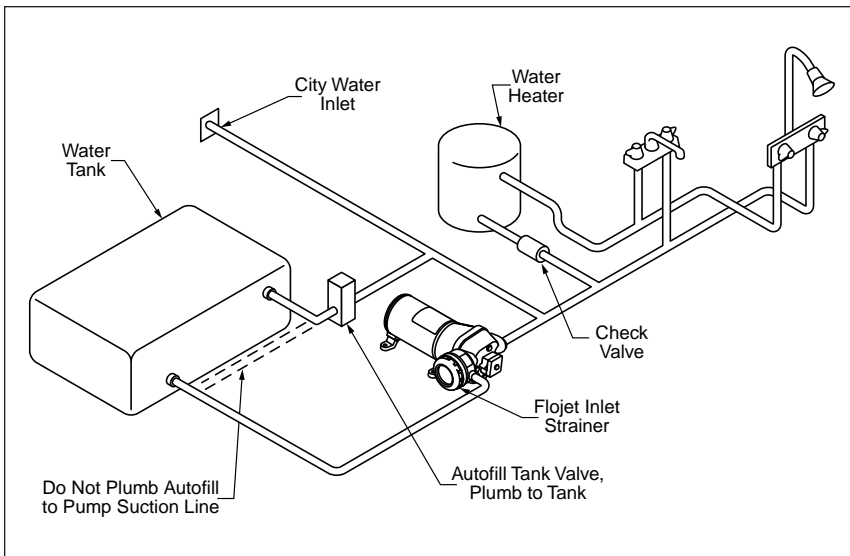

INSTALLATION

STEP 1

Remove the shipping plugs from the Quad pump ports. Some water from factory testing may spill out.

STEP 2

Install strainer on inlet A and port adapter on outlet B. Firmly push slide clips C forward to lock strainer and port adapter in place. Install port adapter to strainer inlet (not shown) and firmly push slide clip forward to lock port adapter.

STEP 3

Mount pump horizontally, or vertically with the pump-

head lower than the motor. Any plumbing leak should not drip on the motor.

STEP 4

3/4" I.D. hose may be used (preferably braided or reinforced) to isolate pump from plumbing system. 1/2" I.D. hose may be used on 3.7 GPM model. Use hose clamps on hose barb connectors.

STEP 5

Install a 40 mesh in-line strainer in an accessible location between the supply and the pump inlet A.

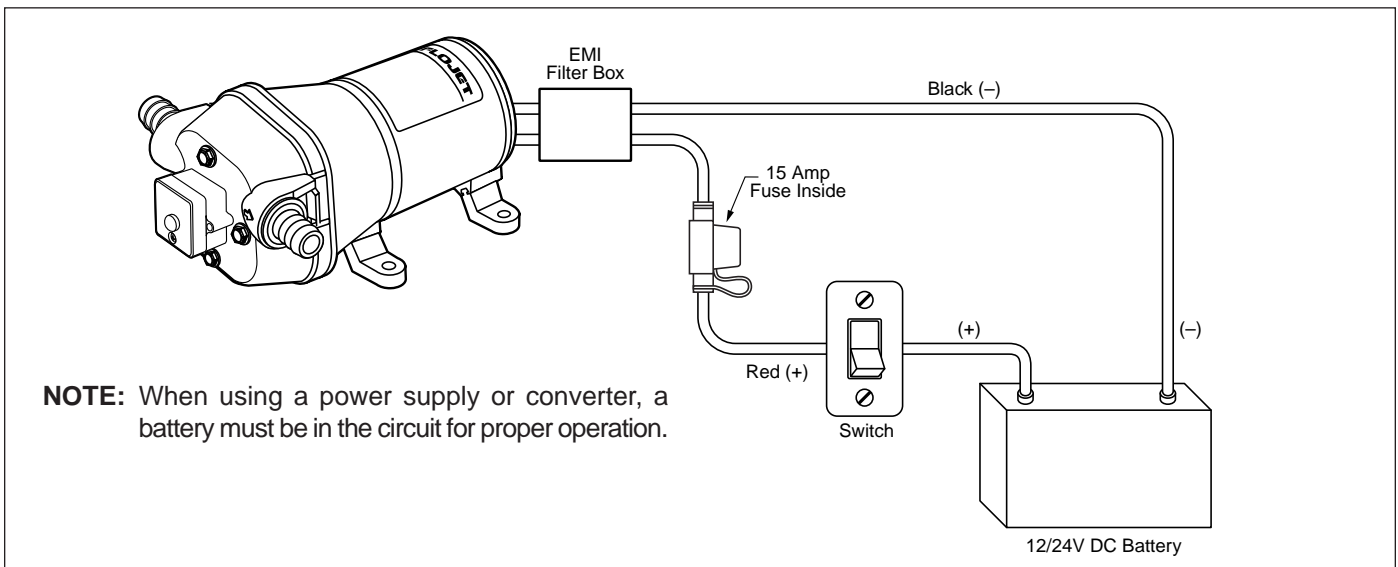

WIRING

The Automatic Variable Speed Motor Driven Pumps will operate in either a 12 or 24 volt DC battery system. The unique electronics adjust the voltage and current to the motor as needed.

STEP 1

Use 14 AWG stranded wire to 15 feet, 12 AWG to 30 feet and 10 AWG to 50 feet from distribution panel or power source.

STEP 2

Install a 15 amp rated on-off switch on the positive (+) lead from the power source.

STEP 3

Use a 15A fuse/breaker in the circuit at the distribution panel.

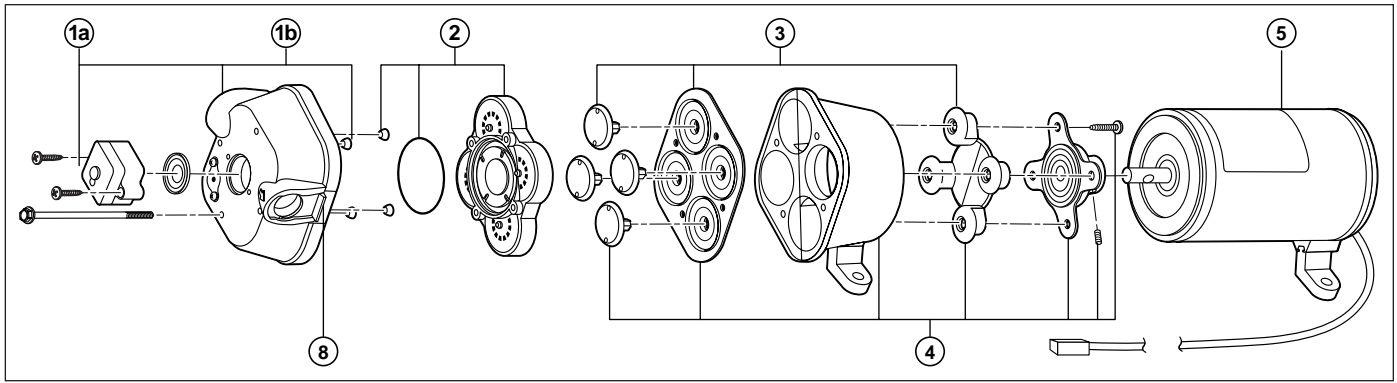

VARIABLE SPEED WATER PUMP SERVICE PARTS

Key	Description	Model #4515-743	Model #4525-743
0	Service Kit*	20409-043	20409-043
1	Upper Housing with Sensor Housing	20404-027	20404-028
2	Check Valve Assembly	20407-030	20407-030
3	Diaphragm Assembly (includes screws)	20403-040	20403-040
4	Lower Housing Assembly	20419-002	20419-002
5	Motors with Sensor	R2009-128A	R2009-127A
7	Pump Head Assembly	20406-037A	20406-038A
8	Side Clips (pair)	20408-000	20408-000

*Service Kit includes #2, #3, #8 and drive cam assembly.

DISASSEMBLE

Pressure Sensor

1. Remove cover (1a) and lift up clip to unplug the sensor (not shown). Remove sensor housing.

Upper Housing

2. Loosen but do not remove the four pump head screws and carefully remove the upper housing assembly (1b).
3. Inspect the B/F valve in center behind sensor for debris.
4. Change the four ferrules sealing the screws.

Check Valve Assembly

5. Inspect the valve flappers for debris and resilience.
6. Replace if necessary.

Lower Housing, Diaphragm, Motor

7. Remove mounting feet to expose notches. Rotate the lower housing (4) so notch opening exposes set screw that holds bearing housing to motor shaft.
8. Loosen the set screw with an 1/8" Allen wrench inserted through the notch opening. Finally, slide lower housing (4) off motor shaft.

Diaphragm Cont'd

9. Remove four piston screws from cam bearing assembly using a Phillips screw driver and pull apart cam bearing assembly from inner pistons.

Motor Cont'd

10. Test motor by very carefully connecting red wire to positive (+) and black wire to negative ground (-) of a 12 or 24Vdc battery. Motor will run full speed and slow as sensor is brought closer to a magnet's south pole. Replace if necessary.

REASSEMBLE

Motor

1. Assemble lower housing assembly (4) to motor. (Follow steps 4 to 10.)

Diaphragm

2. Diaphragm (3) and lower housing (4) are assembled in this way:
 - Four black inner piston facing stem up on a flat surface, diaphragm flat side up with piston stems through diaphragm.
 - White outer piston must be folded to insert into lower housing, flat side up.
 - Hex stem of inner pistons must align with hex holes in outer pistons.
 - Outer pistons must be aligned with alignment slots on the cam bearing assembly.
 - Drive each Phillips head screw partially tight, carefully center each piston in its quadrant, and then tighten the screws securely (18 in. lbs. torque).

Lower Housing

3. Attach lower housing to motor shaft by aligning indentation in shaft with set screw. Set screw must align with the shaft indentation or major damage, poor performance or high amp draw may result.

Upper Housing, Check Valves

4. View the inside of the upper housing (1) and seat the four ferrules in the pump head screw recesses.
5. Carefully seat the O-ring in the check valve assembly (O-ring must not slip out of the check valve recess.)
6. Install check valve assembly into upper housing, pressing firmly. Start the four pump head screws, turning by hand through the ferrule seals, then push through about 1 1/2 ".
7. Assembly on to lower housing (4), align four screws to motor by rotating lower housing if necessary to align feet.
8. Tighten pump head screws evenly to a watertight 30 in. lbs. torque.

Pressure Sensor

9. Place sensor housing (1a) and sealing disk against upper housing (1b), insert screws and take care not to cross thread or strip out threads in upper housing.
10. Slide the sensor under the clip on the sensor housing, and install the cover.

TROUBLESHOOTING



WARNING: BEFORE SERVICING PUMP, TURN OFF POWER TO PUMP AND DRAIN SYSTEM!!

Failure to Prime - Motor operates, but no water flows

- | | |
|--|--|
| <ul style="list-style-type: none"> • Debris in pump: • Defective check valve assembly: • Air leak in intake line: • Restricted intake or discharge line: • Punctured diaphragm (pump leaks): • Crack in pump housing (pump leaks): • Empty water supply tank: | <ul style="list-style-type: none"> Remove upper-housing and clean Replace check valve assembly Tighten all clamps, inspect plumbing Remove lines and inspect Replace lower housing assembly Replace housing or pump head Refill or turn power off to pump |
|--|--|

Motor fails to run

- | | |
|--|---|
| <ul style="list-style-type: none"> • Pump circuit has no power: • Loose or corroded wiring connection: • Blown fuse or open breaker: • Open thermal protector (motor shell hot): • Defective motor, drive control or pressure sensor: | <ul style="list-style-type: none"> Check wiring, fuse or breaker Inspect wire connections Replace or reset Wait 20 to 30 minutes for auto reset Contact factory, 1-800-2FLOJET |
|--|---|

Pump fails to turn off after all fixtures are closed

- | | |
|--|--|
| <ul style="list-style-type: none"> • Empty water supply tank: • Air trapped in pump: • Debris in pump: • Defective check valve assembly: • No battery in Circuit • Punctured diaphragm (pump leaks): • Discharge line leak: | <ul style="list-style-type: none"> Refill Open faucet closest to pump Remove upper-housing and inspect Replace check valve assembly Install battery Replace lower housing assembly Inspect plumbing for leaks |
|--|--|

Low flow or pressure

- | | |
|--|---|
| <ul style="list-style-type: none"> • Debris in inlet strainer: • Water filter needs changing: • Under size plumbing or long runs: • Defective motor, drive control or pressure sensor: | <ul style="list-style-type: none"> Remove cover and clean screen Replace filter cartridge Increase plumbing I.D. Contact factory, 1-800-2FLOJET |
|--|---|

ACCESSORIES

Quick Connect Port System

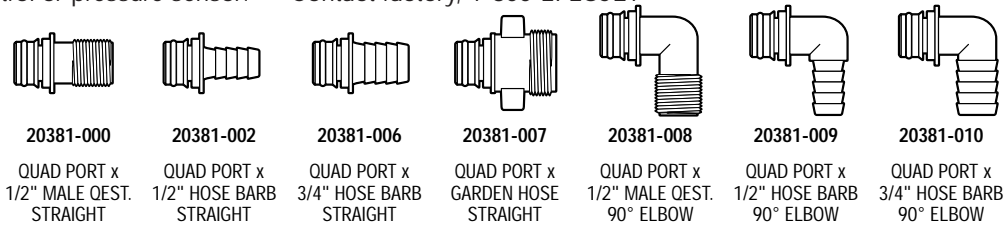

STRAINERS

Pump Series	Strainer Number	Inlet	Outlet	Screen
R4515-743	1740-012	1/2 Barb	Quad Port	40 Mesh
	1740-002	1/2 Barb	1/2 Barb	40 Mesh
	1740-004	1/2 M Qest	1/2 M Qest	40 Mesh
	1740-014	1/2 M Qest	Quad Port	40 Mesh
	1740-900*	Female Quad Port	Quad Port	40 Mesh
R4525-743	1740-000	3/4 Barb	3/4 Barb	40 Mesh
	1740-004	1/2 M Qest	1/2 M Qest	40 Mesh
	1740-014	1/2 M Qest	Quad Port	40 Mesh
	1740-900*	Female Quad Port	Quad Port	40 Mesh

* Included with pump

WARRANTY

FLOJET warrants this product to be free of defects in material and/or workmanship for a period of two years after purchase by the customer from FLOJET. During this two year warranty period, FLOJET will at its option, at no charge to the customer, repair or replace this product if found defective in material or workmanship, with a new or reconditioned product, but not to include costs of removal or installation.

This is only an overview of our limited warranty. If you would like a copy of our warranty, please call or write FLOJET.

RETURN PROCEDURE

Prior to returning any product to FLOJET, call customer service for an authorization number. This number must be written on the outside of the shipping package. Place a note inside the package with an explanation regarding the reason for return as well as the authorization number. Include your name, address and phone number.

Flojet



ITT Industries
Engineered for life

U.S.A.
Flojet
20 Icon
Foothill Ranch, CA 92610-3000
Tel: (949) 859-4945
Fax: (949) 859-1153

UNITED KINGDOM
Jabsco/Flojet
Bingley Road, Hoddesdon
Hertfordshire EN11 0BU
Tel: +44 (0) 1992 450145
Fax: +44 (0) 1992 467132

CANADA
Fluid Products Canada
55 Royal Road
Guelph, Ontario N1H 1T1
Tel: (519) 821-1900
Fax: (519) 821-2569

JAPAN
NHK Jabsco Company Ltd.
3-21-10, Shin-Yokohama
Kohoku-Ku, Yokohama, 222
Tel: 045-475-8906
Fax: 045-475-8908

GERMANY
Jabsco GmbH
Oststrasse 28
22844 Norderstedt
Tel: +49-40-53 53 73-0
Fax: +49-40-53 53 73-11