

INSTALLATION & OPERATION INFORMATION FOR MODELS G70C XXX

PRODUCT DATA

Pump Design Double Diaphragm

Wetted Parts

Body and Check Valves Polypropylene
Diaphragm Kalrez® 6190
Check Valve Seals Viton® Extreme™
Springs Hastelloy®

Ports Air Inlet 1/4" (6.3 mm)

Liquid Inlet 3/8" (9.5 mm) - 1/2" (12.7 mm) - 3/4" (19.1 mm)

Liquid Outlet 3/8" (9.5 mm) - 1/2" (12.7 mm) - 3/4" (19.1 mm)

Net Weight 1.2 lbs. (0.54kg)

DESCRIPTION

FLOJET Industrial G70C Pumps are designed for general commercial and industrial applications. These pumps are constructed from a selection of materials for handling a broad range of chemicals.

Allowed fluids for Kalrez® parts

Lubricating Oils,
Hydraulic Oils,
Vegetable Oils,
Alcohols, Keytones,
Aromatic Hydrocarbons,
Aliphatic Hydrocarbons,
Diluted Acids, Alkalis,
Soaps with solvents,
Automotive brake fluid,
Acetones, Ethanol, inks.

Not Allowed fluids for Kalrez® parts

Halogenated Solvents

Note: Refer to page 4 for
General Safety Information.

MARKS AND GENERAL INFORMATION

In compliance with the 94/9/CEE standards, the pumps carry the following identification marks:



II 2G c IIB TX



: safety symbol to Din 40012

II 2G: surface equipment for use in areas with the presence of gases, vapors or mists in addition to clouds of combustible dust in the air that occur occasionally during normal operation (EN 1127-1 par. 6.3), both in external and internal areas (ZONE 1).

c: protection by constructional safety (EN 13463-5)

IIB: Excluding the following products hydrogen, acetylene, carbon disulphide.

TX: Class of admitted temperatures. The processed fluid temperature value must fall within such class range and the user must comply with the instructions contained in the manual and with the current laws. Furthermore, the user must take into account the ignition point of the gases, vapors and mists in addition to clouds of combustible powder in the air existing in the area of use.

PERFORMANCE SPECIFICATIONS

Liquid Temperature Range: 40 - 120°F (4.4 - 48.9°C)
Air Inlet Pressure: 20 - 100 PSI (1.4 - 6.9 Bar)
Inlet Temperature: 40 - 130°F (4.4 - 54.4°C)
Relative Humidity: 0 - 1%

Environment Temperature: 40 - 130°F (4.4 - 54.4°C)

Priming Dry: 15 ft. (4.5 m)

Wet: 20 ft. (6.1 m)

Flow Rate Up to 5.0 GPM (18.9 LPM)

Noise Level Max 87dB

NOTE: Pump Operation must remain within tolerances specified above

Kalrez® and Viton® Extreme™ are trademarks or registered trademarks of DuPont Performance Elastomers. DuPont is a registered trademark of DuPont and its affiliates. Hastelloy® A registered trademark of Haynes International, Inc. John Guest® A registered trademark of John Guest International, Limited.

PERFORMANCE: KALREZ® WITH 1/2" PORTS

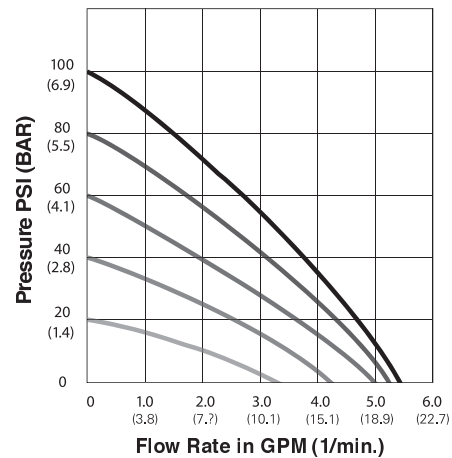

Air In (PSI)	Air Flow Rate (SCFM)
40	1.0
60	1.3
80	1.7
100	2.2

DIMENSIONAL DRAWING

Inches (millimeters)

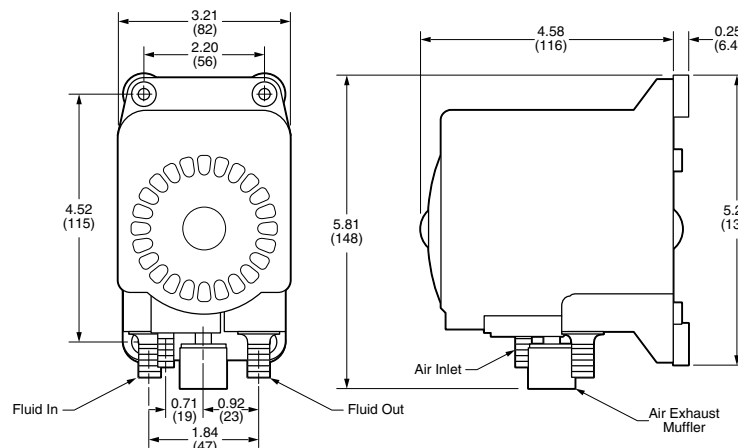

MOUNTING

The FLOJET G70C self-priming pump should be mounted in a dry and adequately ventilated area. This pump can be mounted several feet from the tank, above or below the fluid level. For most applications, no more than 4 feet above the fluid level is recommended. Note: **This is not a submersible pump.**

Secure Pump to desired fixture by inserting screws through the rubber grommets in the baseplate of the pump. **Ports must be facing down.** The pump must be protected by a housing able to withstand the impact of a steel half ball of 25mm with a mass of 1Kg and an energy of 7J. Refer to EN 13463-1 Par 13 for further details.

HOSE CONNECTIONS

Liquid In - Use 3/8", 1/2", or 3/4" I.D. reinforced hose or equivalent. Avoid sharp bends that could restrict flow or cause hose to collapse under vacuum.

Liquid Out - Use 3/8", 1/2", or 3/4" I.D. reinforced hose for discharge tube. 3/4" I.D. hose must use 90° elbows when using large muffler.

Air In - Make sure air regulator is set at zero. Use reinforced 1/4" I.D. hose. Connect "Air In" to air supply fitting on regulator. If pumps are installed in an enclosed area, it is recommended to connect a hose to the air discharge port (exhaust) and vent air to atmosphere (Requires small exhaust port PN# 20756103B not included).

PLUMBING

Use a flexible hose to avoid excess stress on pump ports. **DO NOT** crimp or kink hose. All hose should be the same size as the pump port fittings. All fittings and hose must be compatible with fluid being pumped. It is recommended to use plastic fittings only.

The use of check valves in the plumbing system could interfere with the priming ability of the pump. If unavoidable, check valves in the pumping system must have a cracking pressure of 2 PSI or less.

Use a minimum 40 mesh strainer or filter in the tank or pump inlet line to keep large foreign particles out of the system. Liquid inlet port must be equal to or larger than the liquid outlet port.

OPERATION

At start-up, regulate air pressure to desired setting. For most installations 20 PSI (1.4 bar) inlet will be adequate, although **DO NOT** go below 20 PSI. Pump will operate according to air supply. Flow and pressure can be adjusted by increasing or decreasing air pressure to accommodate varying product viscosities, length of lines or other installation conditions. Review flow curves located on page 1 for further assistance. High viscosity fluids and hose length will limit priming distance.

Compressors must have dryers and/or a water separator in the air distribution system. Pumps that fail due to water in the air chamber will not be covered under the limited warranty.

Plastic air inlet ports do not have a check valve. Prior to cleaning or servicing, purge the pump by carefully tilting the pump so ports are facing up and remove suction line from

source. Turn air off and disconnect air inlet line. (Standard brass air inlet ports have a check valve).

DISASSEMBLY PROCEDURE

First, remove inlet air line, muffler and suction/discharge line from the pump. This is accomplished by using a flat-bladed screwdriver to slide the retaining clips away from the air inlet, muffler and suction/discharge fittings and pulling the fittings away from the pump body. Now remove the muffler by sliding the retaining clip away from the muffler base and pulling the muffler out of the pump body.

Using a Phillips screw driver remove the seven (7) screws from the front end cap followed by the (7) screws from the rear end cap. With the front end cap facing up and the rear end cap facing down on the workbench, position a flat bladed screw driver into the slot located above the muffler port and just below the pad marked Air/CO₂ and lift off the front end cap. The rear end cap can be removed by placing the flat bladed screwdriver under the fully opened port retaining clip and lifting off.

Note the position of the suction and discharge valves before removing them from the pump body. The first diaphragm is removed from the pump shaft by unscrewing in a counter clockwise direction. The second diaphragm is removed by placing the flat tip of a screwdriver into the exposed slot at the end of the pump shaft and unscrewing the diaphragm from the shaft. To remove the flange housing, place the tip of the flat bladed screw driver into the air bleed hole on the lower side of the flange housing and lift up the lower end separating the flange housing from the pump body.

The slide valve assembly and pump shaft can be removed by simply pulling them from the pump body. The pump shaft then can be removed from the slide valve yoke assembly.

REASSEMBLE PROCEDURE

Assemble the slide valve and pump shaft with the yoke placed between the (2) bumpers on the pump shaft. Install the slide valve/pump shaft assembly into the pump body making sure the O-rings in the slide valve are in place. To install the flange housing, prelube the o-ring with Parker Super "O" Lube and install on flange housing and place housing over the pump body aligning the flange housing with the pump body ribs pressing it into place.

Install the first diaphragm and O-ring on to the pump shaft by threading on to shaft using a flat blade screwdriver to hold the pump shaft until the diaphragm is tight. Install the second diaphragm and O-ring on to the pump shaft turning clockwise until tight.

Install the suction valves with springs facing into the pump body and the discharge valves with the springs facing out. See arrows on pump rear end cap below suction and discharge ports.

Install the port retainer clips (large) into the pump end cap (mounting base) and install the seven (7) Phillips screws into pump body and cross tighten until snug and then cross torque to 22-24 inch pounds. Install port retaining clips (small) into the pump body with tabs facing out. Position the front end cap and install the seven (7) Phillips screws into pump body and cross tighten until snug and then cross torque to 22-24 inch pounds.

Install the muffler in the center port by pushing it in and sliding the retainer clip into place. Install the suction and discharge ports and the air inlet port fitting and slide the retainer clips in place. Check for leaks.

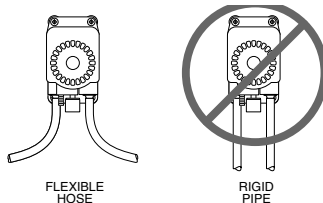

MODEL G70C SERIES EXPLODED VIEW

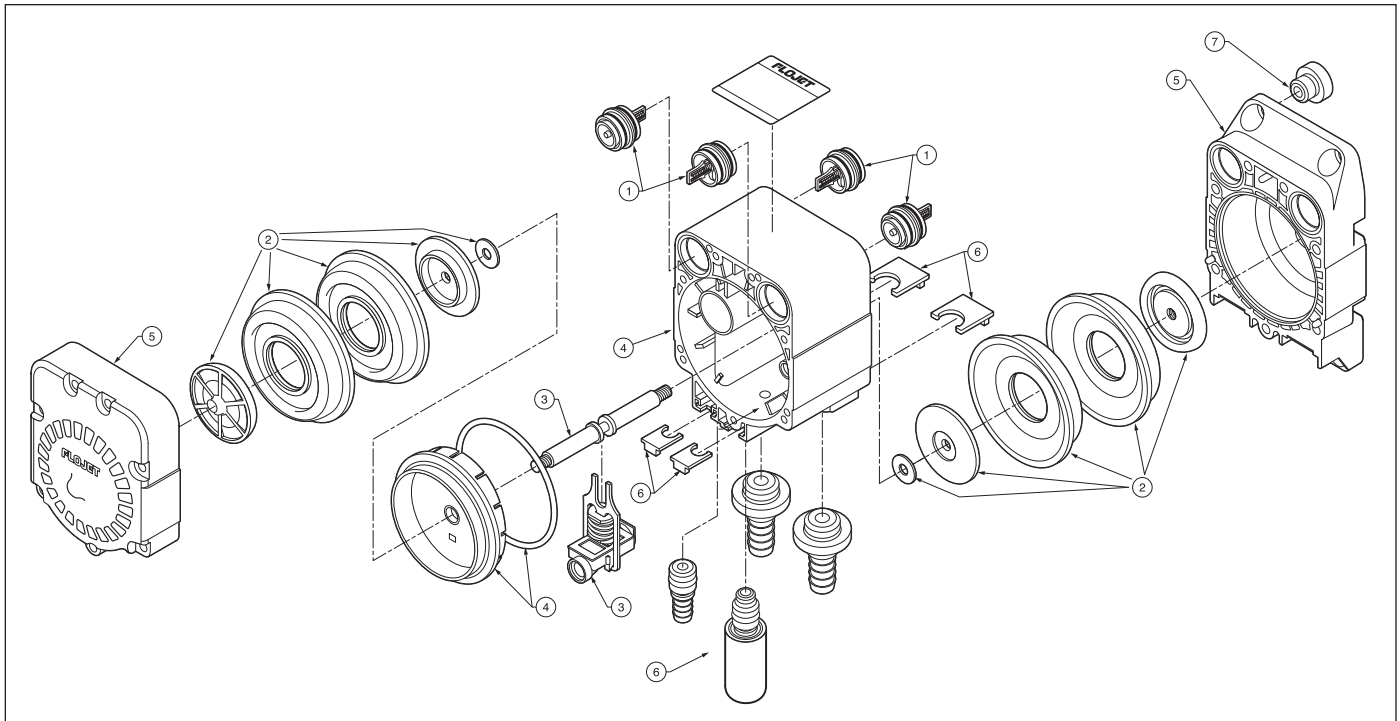

Key	Part No.	Description	Qty
1	20740122A	Kit, Check Valve, Assy., Polypropylene Viton® Extreme™, Hastelloy®	4
2	21000661A	Kit, Diaphragm, Kalrez®	2
3	20751002A	Kit, Shaft & Slide Valve Assy.	2
4	xxxxxxxxxA	Kit, Flange & Housing Assy. w/"O" Ring	2
5	xxxxxxxxxA	Kit End Caps	2

Key	Part No.	Description	Qty
6	20758200A	Kit Hardware - Includes	
		Screws #10 x 1.5" Hi Low	14
		Retainer Clip Small	2
		Retainer Clip Large	2
		Exhaust Port (Port x 1/4" HB)	1
		Exhaust Muffler	1
7	20132000	Kit, Grommets	4

G70C PORT FITTINGS (All liquid fittings include Viton® Extreme™ for O-ring.)

Part No.	Description	Qty
20381093	10/13mm HB, 90° Elbow	2
20381094	1/2" NPT, Male, Straight	2
20381095	3/8" NPT, Male, Straight	2
20381096	10/13mm HB, Straight	2
20381097	3/4" HB, Straight	2
20381099	1/2" HB, Straight	2

Part No.	Description	Qty
20381100	1/2" HB, 90° Elbow	2
20381101	3/4" HB, 90° Elbow	2
21000663	1/2" OD John Guest®	2
21000664	3/8" OD John Guest®	2
01510000	1/4" HB, Straight Brass (Air In) Buna O-Ring	2
20325033	1/4" HB, Straight Plastic (Air In) Buna O-Ring	2
20756103B	Air Exhaust Port x 1/4" HB, O-ring Polypropylene Viton®	12

MODEL NUMBERING MATRIX

G57C XX X X

PORTS (Liquid Inlet / Outlet)

00 - NO PORT
 14 - 1/2 OD JOHN GUEST™ PLASTIC
 17 - 1/2 NPT, MALE, STRAIGHT
 18 - 3/8 NPT, MALE, STRAIGHT
 20 - 3/8 STRAIGHT HOSE BARB
 21 - 1/2 STRAIGHT HOSE BARB
 22 - 3/4 STRAIGHT HOSE BARB
 23 - 3/8 ELBOW HOSE BARB
 41 - 3/8 OD JOHN GUEST™ PLASTIC

ELEMENT (Air Inlet / Outlet)

2 - 1/4 STRAIGHT HOSE BARB BRASS, SMALL MUFFLER
 3 - 1/4 ELBOW HOSE BARB BRASS, SMALL MUFFLER

PACKAGING

A - SINGLE PACK
 D - BULK PACK (72)

GENERAL SAFETY INFORMATION

Follow all safety codes and the Occupational Safety and Health Act (OSHA).

 These User Instructions contain specific safety markings where non-observance of an instruction would cause hazards. The specific safety markings are:

 This symbol indicates safety instructions where non-compliance would affect personal safety and could result in serious injury.

 **CAUTION** This symbol indicates safety instructions where non-compliance will involve some risk to safe operation and personal safety and would damage the equipment and or property.

 **Do NOT pump** Gasoline or flammable fluids with flash point below 98°F (37°C) Explosion or serious injury may occur.

 Incompatible fluids may cause premature failure of the pump. It is the customer's responsibility to ensure that fluids are compatible with pump materials.

 If used with **CO₂ or N₂** be sure the area is well ventilated.

 **CAUTION** If pump is to be used in high flow, low pressure applications, adjust air pressure to 20 PSI (1.38 bar) above discharge pressure.

 **CAUTION** **Do NOT** Exceed 100 PSI (6.9 bar) Air Inlet Pressure.

 **CAUTION** Continuous operation above 120°F (48.9°C) will reduce pump life.

 **CAUTION** Inlet air must be dry and oil free - use an air/oil filter and air dryer.

 **CAUTION** Mount with ports facing down.

 To Reduce the risk of static sparking, ground the pump and all other equipment used or located in the pumping area. Check your local electrical code for detailed grounding instructions for your area and type of equipment.

TROUBLESHOOTING CHART

Symptom	Possible Cause(s)	Corrective Action
Pump will not start (stalls)	<ol style="list-style-type: none"> Inadequate air supply (20 PSI Min.) Contaminated air supply Ruptured diaphragm (2) Check shuttle valve for wear (11) 	<ol style="list-style-type: none"> Increase air inlet pressure An air dryer might be required Replace diaphragm (2) Replace shuttle valve if necessary (11)
Pump runs, but no fluid	<ol style="list-style-type: none"> A leak or break in the product inlet line A leak or break in the product discharge line 	<ol style="list-style-type: none"> Replace product line Replace product line
Pump leaks through exhaust port	<ol style="list-style-type: none"> Leak at upper exhaust port o-ring (13) Shaft seal o-rings damaged or worn Inadequate slide lubrication 	<ol style="list-style-type: none"> Replace exhaust port (13) Replace shaft seal o-rings Replace with shuttle valve kit
Flow rate is low	<ol style="list-style-type: none"> Tubing or hose is damaged or blocked Check viscosity of medium being pumped Check valves not seated correctly (6) 	<ol style="list-style-type: none"> Clean or replace Reduce viscosity of medium, increase hose diameter or contact factory for recommendation Reinstall check valves (6)
Pump leaks	<ol style="list-style-type: none"> Ruptured or worn out diaphragm (2) Pump housing screws not torqued adequately 	<ol style="list-style-type: none"> Replace diaphragm (2) Torque screws to 20 in lb

 When using high pressure gas tanks make sure a secondary regulator is used to avoid accidental damage to pump.

 **CAUTION** Do not clean or service FLOJET pumps, hoses or valves while the system is pressurized.

 **CAUTION** This is not a submersible pump - use only in dry environments.

PREVENTIVE MAINTENANCE TIPS

Tips to help prolong your pump's life.

- If pumping liquid other than water, pump should be flushed with water (if applicable) after every use.
- Before freezing conditions occur, pump must be liquid free.
- If mounting pump in an outdoor environment, shield pump from environmental extremes (i.e. sunlight, water from washdown spray, rain, etc.). Avoid high heat and humid installations.
- When using an air compressor, use an inline air dryer (PN# FJ520B) before the pump to limit water build-up.

WARRANTY

FLOJET warrants this product to be free of defects in material and/or workmanship for a period of one year after purchase by the customer from FLOJET. During this one year warranty period, FLOJET will at its option, at no charge to the customer, repair or replace this product if found defective, with a new or reconditioned product, but not to include costs of removal or installation. No product will be accepted for return without a return material authorization number. All return goods must be shipped with transportation charges prepaid. This is only a summary of our Limited Warranty. For a copy of our complete warranty, please request Form No. 100-101.

RETURN PROCEDURE

Prior to returning any product to FLOJET, call customer service for an authorization number. This number must be written on the outside of the shipping package. Place a note inside the package with an explanation regarding the reason for return as well as the authorization number. Include your name, address and phone number.

**For more information visit us
online at www.flojet.com**