

# FLOJET

## G-57 Series Industrial Air Driven Pump

G-57 Series Industrial Air Driven Pump

### INSTALLATION & OPERATION INFORMATION FOR MODELS G573XXX THROUGH G575XX

#### PRODUCT DATA

<b>Pump Design</b> .....	Duplex Diaphragm
<b>Wetted Parts</b> .....	Diaphragm Material Santoprene® or Viton®
	Check Valve Seat Material Santoprene® or Viton®
	Housing and check valve material
	.....Polypropylene (Glass Reinforced)
	Springs .....
	.....Hastelloy
<b>Ports</b> .....	Gas Inlet & Outlet 1/4" (6.3 mm)
	Product Inlet 3/8" (9.5 mm) - 1/2" (12.7 mm) - 3/4" (19.1 mm)
	Product Outlet 3/8" (9.5 mm) - 1/2" (12.7 mm) - 3/4" (19.1 mm)
<b>Net Weight</b> .....	1.2 Pounds (0.54kg)

® A registered trade mark of Monsanto Co.  
 ® A registered trade mark of I.E. DuPont Co.

#### DESCRIPTION

FLOJET Industrial G-57 Series Pumps are designed for general commercial and industrial applications. These pumps are constructed from a selection of materials for handling a broad range of chemicals.

**Allowed fluids for Santoprene® materials**  
 Potable Water, Acids  
 Alkaline, Soaps  
 Alcohols, Ketones

**Allowed fluids for Viton® materials**  
 Oils, Solvents, D-Limonene,  
 Aromatic & Halogenated  
 Hydrocarbons, Acids

**Not Allowed fluids for Santoprene® materials**  
 Oils, Solvents, Soaps with  
 Solvents, D-Limonene,  
 Aromatic Hydrocarbons

**Not Allowed fluids for Viton® materials**  
 Ketones, Acetones,  
 Automotive Brake Fluid,  
 Ammonia, Ethanol

#### PERFORMANCE SPECIFICATIONS

##### PUMP

<b>Liquid Temperature</b> Min .....	40°F (4.4°C)
.....Max .....	120°F (48.9°C)
<b>Priming</b> .....	Dry .....
	.....15 ft. (4.5 m)
	Wet .....
	.....20 ft. (6.1 m)
<b>Flow Rates</b> .....	Max .....
	.....Up to 5 GPM (18.9 L/min)
<b>Gas Supply Pressure</b> .....	20 to 100 PSI (1.4 to 6.9 bar)
<b>Noise Level</b> .....	Max .....
	.....87dB

#### Santoprene and Viton Material with 1/2" Ports

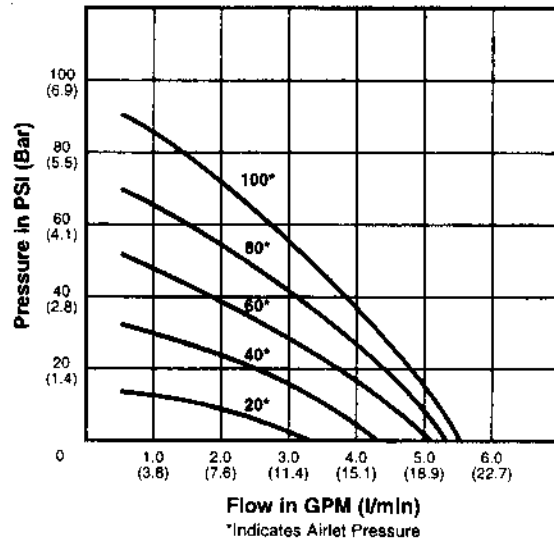

#### DIMENSIONAL DRAWING

Inches (millimeters)

Dimensional tolerances ± 0.06 inches

Consult factory if precise details are required.

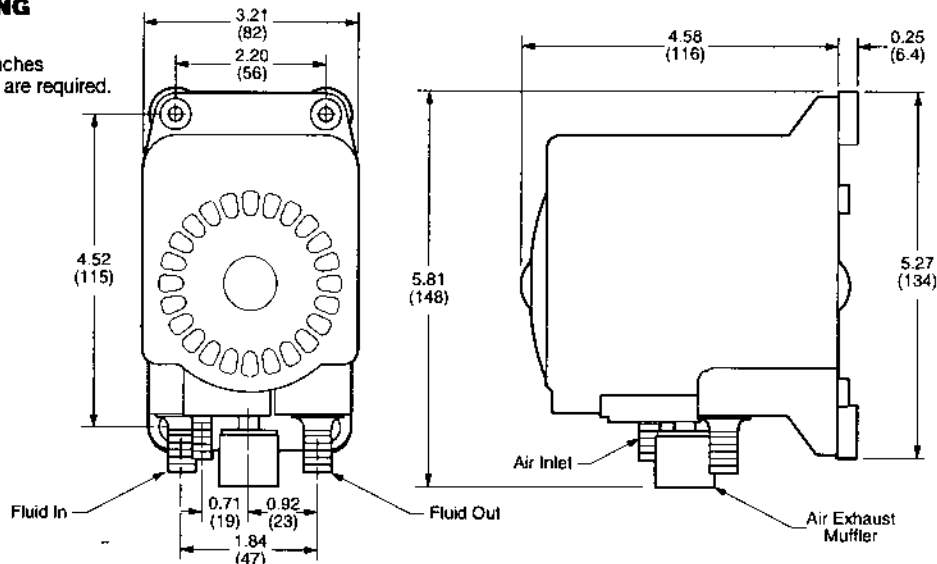

## MOUNTING

The FLOJET G-57 Series self-priming pump should be mounted in a dry and adequately ventilated area. This pump can be mounted several feet from the tank, above or below the fluid level. For most applications, no more than 4 feet above the fluid level is recommended. **This is not a submersible pump.**

Secure Dump to desired fixture by screws through the rubber grommets in the baseplate of the pump. **Ports must be facing down.** Contact factory for mounting bracket and hardware options.

## HOSE CONNECTIONS

Product In - Use 3/8", 1/2" or 3/4", reinforced hose or equivalent. Avoid sharp bends that could restrict flow or cause hose to collapse under vacuum.

Product Out - Use reinforced 3/8", 1/2" or 3/4" I.D. hose for discharge tube. 3/4" must use 90° elbows when using large muffler.

Gas In - Make sure gas regulator is set at zero. Use reinforced 1/4" hose. connect "Gas In" to gas supply fitting on regulator. If pumps are installed in an enclosed area, it is recommended to connect a hose to the gas discharge port (exhaust) and vent gas to atmosphere. (Requires 'small' exhaust port)

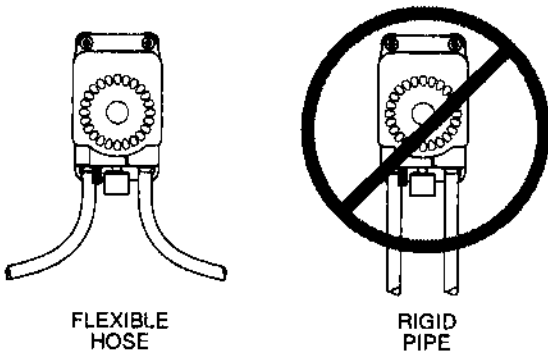

## PLUMBING

Use a flexible hose to avoid excess stress on pump ports. **DO NOT** crimp or kink hose. All hose should be the same size as the pump port fittings.

All fittings must be compatible with fluid being pumped. It is recommended to use plastic fittings only.

The use of check valves in the plumbing system could interfere with the priming ability of the pump. If unavoidable, check valves in the pumping system must have a cracking pressure of 2 PSI or less.

Use a minimum 40 mesh strainer or filter in the tank or pump inlet line to keep large foreign particles out of the system.

## OPERATION

At start-up, regulate gas pressure to desired setting. For most installations 20 PSI (1.4 bar) inlet will be adequate, although **DO NOT** go below 20 PSI. Pump will operate according to air supply. Flow and pressure can be adjusted by increasing or decreasing gas pressure to accommodate varying product viscosities, length of lines or other installation conditions. Review flow curves located on page 1 for further assistance. High viscosity fluids and hose length will limit priming distance. **IF PUMP IS TO BE USED IN HIGH FLOW, LOW PRESSURE APPLICATIONS, ADJUST GAS PRESSURE TO 20 PSI (1.38 BAR) ABOVE DISCHARGE PRESSURE.**

**CAUTION: DO NOT EXCEED 100 PSI (6.9 bar) GAS INLET PRESSURE.**

**CONTINUOUS OPERATION AT 120°F (48.9°C) WILL REDUCE PUMP LIFE.**

**AIR MUST BE DRY AND OIL FREE.**

Compressors must have dryers and/or a water separator in the air distribution system. Pumps that fail due to water in the air chamber will not be covered under the limited warranty.

## GENERAL SAFETY INFORMATION

Protect yourself and others by observing all safety information. Follow all safety codes and the Occupational Safety and Health Act (OSHA).



**WARNING**



**DO NOT PUMP GASOLINE OR FLAMMABLE LIQUIDS OR USE WHERE FLAMMABLE VAPORS ARE PRESENT.**

**If used with CO<sub>2</sub> or N<sub>2</sub> be sure the area is well ventilated.**

## CAUTION:

Do not clean or service FLOJET pumps, hoses or valves while the system is pressurized. Plastic CO<sub>2</sub> air inlet ports do not have a check valve. Prior to cleaning or servicing, purge the pump by carefully tilting the pump so ports are facing up and remove suction line from source. Turn air off and disconnect air inlet line. (Brass air inlet ports have a check valve)

## PREVENTIVE MAINTENANCE TIPS

Tips to help prolong your pump's life.

- If pumping liquid other than water. pump should be flushed with water (if applicable) after every use.
- Before freezing conditions occur. pump must be liquid free.
- If mounting pump in an outdoor environment. shield pump from environmental extremes (i.e. sunlight. water from washdown spray, rain, etc.).
- When using an air compressor. use an inline air dryer before the pump to limit water build-up.

## MODEL G57 SERIES EXPLODED VIEW

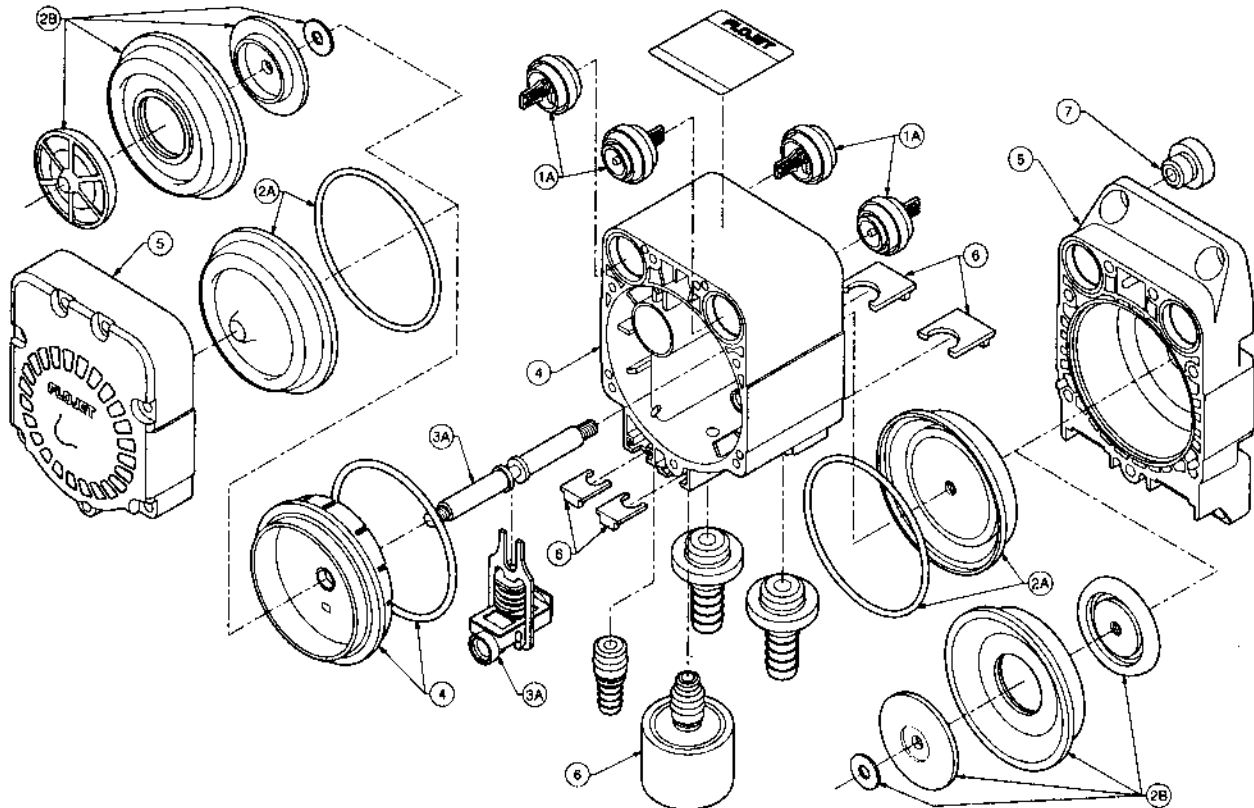

Key	Part No.	Description	Qty
1A	20740-050A	Kit, Check Valve, Assy., Santo <sup>®</sup> , Hastelloy	4
1B	20740-020A	Kit, Check Valve, Assy., Viton <sup>®</sup> , Hastelloy	4
2A	20730-000A	Kit, Diaphragm, Santo.&, w/"O" rings	2
2B	21000-209	Kit, Diaphragm, Viton <sup>®</sup>	2
3A	20751-000A	Kit, Shaft & Slide Valve Assy. (Santo <sup>®</sup> )	2
3B	20751-002A	Kit, Shaft & Slide Valve Assy. (Viton <sup>®</sup> )	2
4	20896-000A	Kit, Flange & Housing Assy. w/"O" Ring	2
5	20753-000A	Kit End Caps	2

Key	Part No.	Description	Qty
6	20793-100A	Kit Hardware - Includes	
		Screws #10x1.5" Hi Low	14
		Retainer Clip Small	2
		Retainer Clip Large	2
		Exhaust Port	1
		Exhaust Muffler	1
7	20132-000	Kit, Grommets	2

### G57 DISASSEMBLY PROCEDURE

First, remove all gas (air in) lines and suction/discharge fittings from the pump. This is accomplished by using a flat-bladed screwdriver to slide the retaining clips away from the gas (air in) and suction/discharge fittings and pulling the fittings away from the pump body. Now remove the muffler by sliding the retaining clip away from the muffler base and pulling the muffler out of the pump body.

Using a Phillips screw driver remove the seven (7) screws from the front end cap followed by the (7) screws from the rear end cap. With the front end cap facing up and the rear end cap facing down on the workbench, position a flat bladed screw driver into the slot located above the muffler port and just below the pad marked Air/CO<sub>2</sub> and lift off the front end cap. The rear end cap can be removed by placing the flat bladed screwdriver under the fully opened port retaining clip and lifting off.

Note the position of the suction and discharge valves before removing them from the pump body. The first diaphragm is removed from the pump shaft by unscrewing in a counter clockwise direction. The second diaphragm is removed by placing the flat tip of a screwdriver the exposed slot at the end of the pump shaft and unscrewing the diaphragm from the shaft. To remove the flange housing, place the tip of the flat bladed screw driver into the air bleed hole on the lower side of the flange housing and lift up the lower end separating the flange housing from the pump body.

The slide valve assembly and pump shaft can be removed by simply pulling them from the pump body. The pump shaft then can be removed from the slide valve yoke assembly.

### REASSEMBLE PROCEDURE

Assemble the slide valve and pump shaft with the yoke placed between the (2) bumpers on the pump shaft. Install the slide valve/pump shaft assembly into the pump body making sure the O-rings in the slide valve are in place. To install the flange housing, pre-lube the o-ring with Parker Super "O" Lube and install on flange housing and place housing over the pump body aligning the flange housing with the pump body ribs pressing it into place.

Install the first diaphragm and O-ring on to the pump shaft by threading on to shaft using a flat blade screwdriver to hold the pump shaft until the diaphragm is tight. Install the second diaphragm and O-ring on to the pump shaft turning clockwise until tight.

Install the suction valves with springs facing into the pump body and the discharge valves with the springs facing out. See arrows on pump rear end cap below suction and discharge ports.

Install the port retainer clips (large) into the pump end cap (mounting base) and install the seven (7) Phillips screws into pump body and cross tighten until snug and then cross torque to 22-24 inch pounds. Install port retaining clips (small) into the pump body, tabs facing out, position the front end cap and install the seven (7) Phillips screws into pump body and cross tighten until snug and then cross torque to 22-24 inch pounds.

Install the muffler in the center port by pushing it in and sliding the retainer clip into place. Install the suction and discharge ports and the (air in) port fitting and slide the retainer clips in place. Check for leaks.

## MODEL NUMBERING MATRIX

G57X XX X X			
Elastomer/ Spring Material	Ports (Product in and out)	Air Inlet/ Muffler	Packaging Code
5 SANTO Diaphragm	00 No Port Fittings	5 Straight brass 1/4"	A (single pack)
SANTO Check Valve	20 Straight 3/8" HB	6 Elbow 90° brass 1/4"	D (72 bulk pack)
EPDM O-Rings	21 Straight 1/2" HB	7 Tee brass 1/4"	
Hastelloy Springs	22 Straight 3/4" HB	8 Straight Plastic 1/4"	
	23 Elbow 90° 3/8" HB	9 Straight Plastic 1/4"	
3 VITON® Diaphragm	24 Elbow 90° 1/2" HB	*(no muffler element)	
VITON® Check Valve Seat	25 Elbow 90° 3/4" HB		
Hastelloy Springs			

## TROUBLESHOOTING CHART

Symptom	Possible Cause(s)	Corrective Action
Pump will not start (stalls)	<ol style="list-style-type: none"> <li>Inadequate air supply (20 PSI Min.)</li> <li>Contaminated air supply</li> <li>Ruptured diaphragm (2)</li> <li>Check shuttle valve for wear (11)</li> </ol>	<ol style="list-style-type: none"> <li>Increase air inlet pressure</li> <li>An air dryer might be required</li> <li>Replace diaphragm (2)</li> <li>Replace shuttle valve if necessary (11)</li> </ol>
Pump runs, but no fluid	<ol style="list-style-type: none"> <li>A leak or break in the product inlet line</li> <li>A leak or break in the product discharge line</li> </ol>	<ol style="list-style-type: none"> <li>Replace product line</li> <li>Replace product line</li> </ol>
Pump leaks through exhaust port	<ol style="list-style-type: none"> <li>Leak at upper exhaust port o-ring (13)</li> <li>Shaft seal o-rings damaged or worn</li> <li>Inadequate slide lubrication</li> </ol>	<ol style="list-style-type: none"> <li>Replace exhaust port (13)</li> <li>Replace shaft seal o-rings</li> <li>Replace with shuttle valve kit</li> </ol>
Flow rate is low	<ol style="list-style-type: none"> <li>Tubing or hose is damaged or blocked</li> <li>Check viscosity of medium being pumped</li> <li>Check valves not seated correctly (6)</li> </ol>	<ol style="list-style-type: none"> <li>Clean or replace</li> <li>Reduce viscosity of medium, increase hose diameter or contact factory for recommendation</li> <li>Reinstall check valves (6)</li> </ol>
Pump leaks	<ol style="list-style-type: none"> <li>Ruptured or worn out diaphragm (2)</li> <li>Pump housing screws not torqued adequately</li> </ol>	<ol style="list-style-type: none"> <li>Replace diaphragm (2)</li> <li>Torque screws to 20 in lb</li> </ol>

## G57 PORT FITTINGS

PART NUMBER	DESCRIPTION	QTY	PART NUMBER	DESCRIPTION	QTY
20381-002	1/2" HB, Straight, EPDM "O" Ring	2	20381-010	3/4" HB, 90° Elbow, EPDM "O" Ring	2
20381-006	3/4" HB, Straight, EPDM "O" Ring	2	20325-033	1/4" HB, Straight Plastic (Air In)	12
20381-009	1/2" HB, 90° Elbow, EPDM "O" Ring	2	01510-000	1/4" HB, Straight Brass (Air In)	12

For a complete port fitting list please request form No. F1 00-112.

## WARRANTY

FLOJET warrants this product to be free of defects in material and/or workmanship for a period of one year after purchase by the customer from FLOJET. During this one year warranty period, FLOJET will at its option, at no charge to the customer, repair or replace this product if found defective, with a new or reconditioned product, but not to include costs of removal or installation. No product will be accepted for return without a return material authorization number. All return goods must be shipped with transportation charges prepaid. This is only a summary of our Limited Warranty. For a copy of our complete warranty, please request Form No. 100-101.

## RETURN PROCEDURE

Prior to returning any product to FLOJET, call customer service for an authorization number. This number must be written on the outside of the shipping package. Place a note inside the package with an explanation regarding the reason for return as well as the authorization number. Include your name, address and phone number.

## Flojet



**ITT Industries**  
Engineered for Life

U.S.A. Flojet 20 Icon Foothill Ranch, CA 92610-3000 Tel: (949) 859-4945 Fax: (949) 859-1153	UNITED KINGDOM Flojet, Unit 1, Avant Business Centre Denbigh West Industrial Estate Milton Keynes, Bucks, England MK1 1DL Tel: 44 1908 370088 Fax: 44 1908 373731	CANADA Fluid Products Canada 55 Royal Road Guelph, Ontario N1H 1T1 Tel: (519) 821-1900 Fax: (519) 821-2569	JAPAN NHK Jabsco Company Ltd. 3-21-10, Shin-Yokohama Kohoku-Ku, Yokohama, 222 Tel: 045-475-8906 Fax: 045-475-8908	GERMANY Jabsco GmbH Oststrasse 28 22844 Norderstedt Tel: +49-40-53 53 73-0 Fax: +49-40-53 53 73-11
--	--	---	--	---