

Installation for
SHOWER DRAIN/R.O. FEEDER PUMP
"QUAD II DIAPHRAGM" • 4105 SERIES

FLOJET

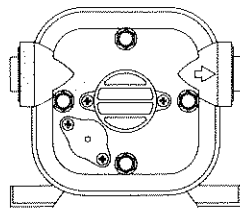
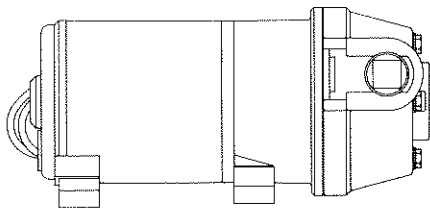
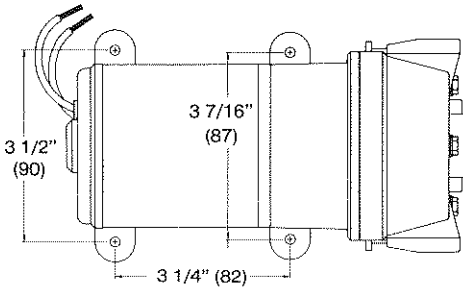

FEATURES

- Self-Priming
- Dry Running
- Soft, Noise Absorbing Mounts
- Corrosion Resistant Materials
- Meet U.S.C.G. Electric Standards

SPECIFICATIONS

Motor: Permanent Magnet, Ball Bearing, O-Ring sealed. CE Models are fully suppressed.

Pump: Four chamber positive displacement diaphragm design; Self-priming up to 6 ft. suction lift; Pump able to run dry without damage; Removable port to hose connectors.

Pump Series	Dimensions - Inches (mm)			Weight lb. (kg)
	Height	Width	Length	
4105-XXX	3.75(95)	6.3(160)	8.2(208)	3.9(1.8)



MODEL*	VOLTS	AMP DRAW @ 10 psi (0.7 bar)	FLOW GPM (l/min)
4105-143	12V dc	3.6	3.3(12.5)
4105-343	24V dc	1.8	3.3(12.5)

* CE fully suppressed models are identified by a prefix "R" and a CE mark on the label (i.e. R4105-343). Self Declaration Of Conformance (SDOC) is available upon request.

OPERATION

Your "Quad II" pump is designed to self-prime up to 6 feet suction lift (vertical distance from shower pan to pump inlet). This pump is quiet running. It is recommended you utilize a "lighted" on-off switch

so that the pump is turned off when not in use. the "Quad II" is able to run dry (no liquid) for extended periods with no damage to the pump. However, this could cause needless battery drain.

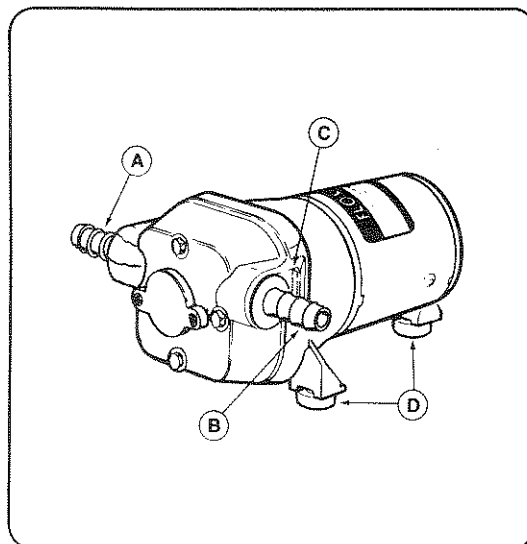
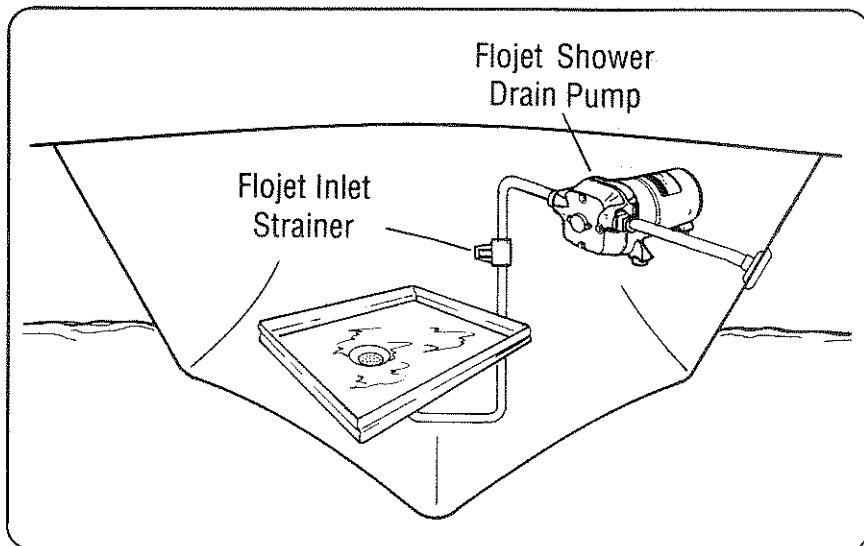

INSTALLATION

STEP 1

Remove shipping plugs from Quad pump ports. Some water from factory testing may spill out.

STEP 2

Install inlet A and discharge B port connectors. Firmly push slide clips C forward to lock port connectors in place.

STEP 3

Slide rubber mounts fully into 4 mounting tracks.

STEP 4

Mount pump vertically, with pump head down or horizontally in an accessible location. If mounting vertically, motor up, attach motor mounts first, then pump head mounts, while supporting weight of pump.

STEP 5

Use 1/2" I.D. flexible hose (preferably braided or reinforced). Use hose clamps on the slip-on barb hose connectors.

STEP 6

Install a 1/2" in line strainer #01740-002 in accessible location between shower drain pan and pump inlet.

This strainer or equivalent is required for pump warranty to be valid.

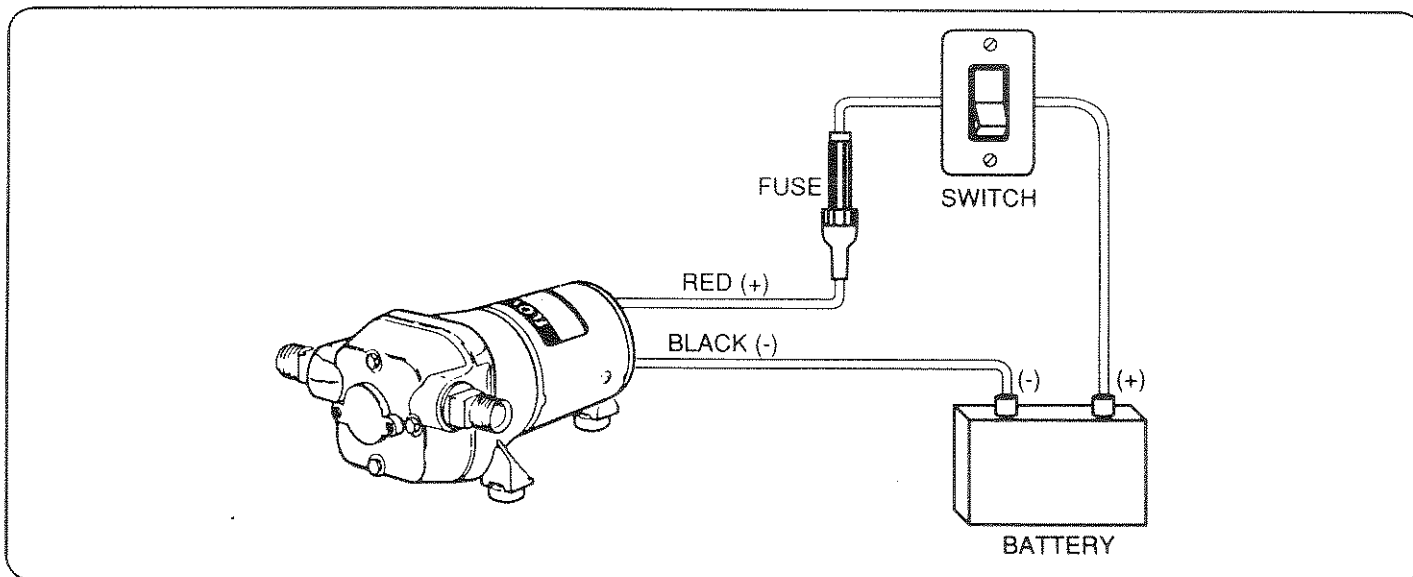

WIRING

STEP 1

Use 14 gauge stranded wire to 20', 12 gauge to 50', from power source.

STEP 2

Use a 10-15 amp rated (lighted) on-off switch on the (+) positive (red) motor lead.

STEP 3

Install 10 amp fuse protection on the positive lead for the -143 model, use a 7 amp fuse for the -343 model.

TROUBLESHOOTING

WARNING: BEFORE SERVICING PUMP, CLOSE SEA COCK, TURN OFF POWER AND DRAIN WATER FROM HOSES !!

Failure to Prime - Motor operates, but no pump discharge

- Restricted intake or discharge line
- Air leak in intake line
- Debris in pump
- Punctured pump diaphragm (water leak)
- Crack in pump housing

Motor fails to turn on

- Blown fuse
- Pump circuit has no power
- Loose wiring connection
- Defective motor

Low Flow and Pressure

- Air leak at pump intake
- Accumulation of debris inside pump and plumbing
- Worn pump bearing (excessive noise)
- Punctured pump diaphragm (water leak)
- Defective motor

Pulsating Flow

- Restricted pump delivery. Check discharge lines, fittings and valves for clogging or undersizing.

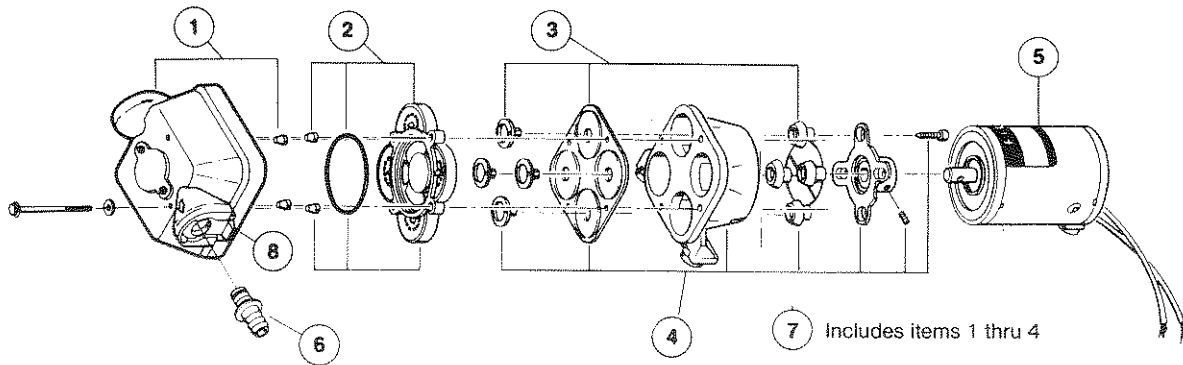

Quite often when a pump is worn or defective the one failed component has overburdened others. To avoid frequent aggravating repairs, Flojet offers service kit assemblies making repairs as quick and easy as possible.

TO DISASSEMBLE

Upper Housing

1. Loosen but do not remove four pump head screws and carefully remove upper housing assembly (1)
2. Inspect check valve (2) for debris
3. Reassemble new upper housing (1)

Check Valve Assembly

Follow step 1

3. Replace check valve (2)
4. Reassemble upper housing (1)

Lower Housing, Diaphragm, Motor

Follow step 1, then slide rubber foot from mounting track.

3. Rotate lower housing (4) so mounting notch opening on lower housing exposes set screw which holds bearing housing to shaft.
4. Loosen this set screw by inserting wrench 1/8" Allen wrench into mounting notch opening. Then, slide lower housing (4) off motor shaft.

Diaphragm Cont'd

5. Loosen four cam piston screws with Phillips head screw driver and pull apart cam from inner pistons. (Pistons should always be replaced when a new diaphragm is installed.)

Motor Cont'd

5. Replace Motor (5)

TO REASSEMBLE

Motor

1. Reassemble lower housing assembly (4) to motor. (Follow steps 4 to 10.)

Diaphragm

2. Lower housing is assembled with:
 - Flat side of diaphragm and outer pistons facing motor
 - Hex stem of inner pistons must be aligned into hex holes in outer pistons (4).
 - Outer pistons must be aligned with alignment slots on cam assembly making sure screw holes align in cam assembly, otherwise diaphragm will leak.
3. Tighten cam piston screws partially, center piston in diaphragm, then tighten screws securely (18 in. lbs. torque)

Lower Housing

4. Reassemble lower housing assembly (4) to motor.
5. Retighten set screw securely. Set screw head must be positioned facing motor covering seam (indentation). (Positioning of this screw is critical to avoid misalignment and subsequent diaphragm damage.)

Upper Housing, Check Valve

6. Reassemble upper housing (1)
7. Properly seat O-Ring in check valve assembly (2) and check if ferrules and screen are in place on upper housing (1)
8. Install check valve (2) into upper housing (1) and push in.
9. Assemble on to lower housing (4), align 4 screws on to motor by rotating lower housing (4) if necessary to align feet.
10. Tighten screws evenly to 30 in. lbs. torque.

SHOWER DRAIN/R.O. FEEDER PUMP SERVICE PARTS

KEY #	DESCRIPTION	MODEL #	
		4105-143	4105-343
0	Service Kit*	20409-043	20409-043
1	Upper Housing with Clips	20404-004	20404-004
2	Check Valve Assembly	20407-030	20407-030
3	Diaphragm Assembly (includes screws)	20403-040	20403-040
4	Lower Housing Assembly	20419-001	20419-001
5	Motors	02009-075A	02019-025A
	Motor CE Models	R2009-075A	R2019-025A
7	Pump Head Assembly	20406-004	20406-004

*Service Kit includes #2, #3, side clips and drive cam assembly.

ACCESSORIES

QUICK CONNECT PORT SYSTEM

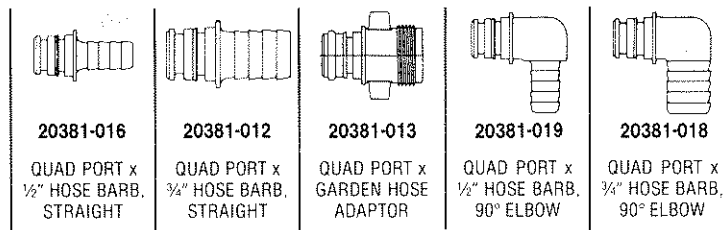

THE ABOVE PART NUMBERS ARE PACKAGED WITH 2 FITTINGS PER BAG

STRAINERS

Pump Series	Strainer Number	Inlet	Outlet	Screen
4105-XXX	1740-012	1/2 Barb	Quad Port	40 Mesh
	1740-002	1/2 Barb	1/2 Barb	40 Mesh

WARRANTY

FLOJET warrants this product to be free of defects in material and/or workmanship for a period of one year after purchase by the customer from FLOJET. During this one year warranty period, FLOJET will at its option, at no charge to the customer, repair or replace this product if found defective, with a new or reconditioned product, but not to include costs of removal or installation. No product will be accepted for return without a return material authorization number. All return goods must be shipped with transportation charges prepaid. This is only a summary of our Limited Warranty. For a copy of our complete warranty, please request Form No. 100-101.

RETURN PROCEDURE

Prior to returning any product to FLOJET, call customer service for an authorization number. This number must be written on the outside of the shipping package. Place a note inside the package with an explanation regarding the reason for return as well as the authorization number. (Include your name and address.)

FLOJET, 20 Icon, Foothill Ranch, CA 92610-3000
 Tel: (949) 859-4945 • (800) 235-6538 • Fax: (949) 859-1153
 E-mail: sales@flojet.com • Website: www.flojet.com
 ISO 9001 Certified

FLOJET, Unit 1, Avant Business Centre
 Denbigh West Industrial Estate
 Milton Keynes, Bucks, England MK1 1DL
 Tel: 44-1908-370088
 Fax: 44-1908-373731

P/N 81000-082 Rev. 02/00

Flojet



ITT Industries
Engineered for life