

Installation & Service Information

Description

FLOJET Industrial Quad Pumps are designed for a wide range of applications and are constructed from a selection of materials suitable for handling a broad range of chemicals. The Quad series of diaphragm pumps are self-priming and can be run dry without harm. They are intended for intermittent duty cycles but can be run continuously for short periods of time. The higher the duty cycle the shorter the expected life of the pump.

Typical pump uses are liquid transfer, spraying, cooling, circulation, filtration and dispensing.

Operation

To start and prime the pump, the discharge line must be open allowing trapped air to escape thus avoiding the potential of airlock. The pressure switch will shut off the pump automatically when the discharge valve is closed and the pressure has risen to the switch OFF set point. The pressure switch will restart the pump when a valve is opened and the discharge line pressure drops to the ON set point of the pressure switch.

Demand Operation (intermittent duty)

Demand Operation is considered an "intermittent duty" application. The maximum intermittent duty cycle is that which will cause the motor to reach its maximum thermal limits. Once the maximum thermal limit is reached, the motor must be allowed to settle to a lower temperature ideally being ambient before resuming operation. Running the pump at or near the maximum thermal limit for extended period of time will shorten the life of the pump and may result in immediate pump failure.

Mounting

The FLOJET Quad Series pumps are self-priming. Vertical prime may vary depending on the fluid viscosity, suction tube size, foot valve and pump configuration. The pump should be mounted in a dry and adequately ventilated area. If mounted within an enclosure, provisions to cool the motor may be necessary.

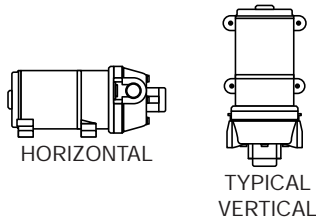

Preventative Maintenance Tips

If pumping a liquid other than water the pump should be flushed with water (if applicable) after each use.

Sealers and Teflon tape acting as a lubricant can cause cracked housings or stripped threads due to over tightening. Care should be used when applying sealers; the tape may enter the pump inhibiting valve action, causing no prime or no shut-off conditions. Failures due to foreign debris are not covered under warranty.

Before freezing conditions occur, the pump must be liquid free or winterized with proper anti-freezing chemicals.

If mounting the pump in an outdoor environment the pump should be shielded from water, dust, sunlight and wash down spray.

Do not assume chemical compatibility. If the fluid is improperly matched to the pumps elastomers, the pump may fail to prime, have low pressures or the pressure switch may not shut off.

Plumbing

Use flexible hose of the correct pressure rating that is compatible with the fluid to be pumped. Tubing should be a minimum of 1/2" (13.0 mm) ID and at least 20 inches (508 mm) in length to avoid excess stress on the pump ports. Do not crimp or kink the tubing.

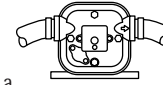

FLEXIBLE HOSE



RIGID PIPE

Flojet 4000 Series ports are a push in type retained by a "C" clip. To install the 4000 ports move "C" clips to rear of pump. Push the port until snug. Slide "C" clip forward to front of pump. Do not install pump such that plumbing causes excessive stress on either port.

The use of check valves in the plumbing system could interfere with the priming ability of the pump. If a check valve is installed in the plumbing it must have a cracking pressure of no more than 2 PSI (.14 bar).

Use of a minimum 40-mesh strainer or filter in the pump inlet line will prevent foreign debris from entering the system. Failures due to foreign debris entering the pump will not be covered under the limited warranty.

Note: Inlet pressure must not exceed 30-PSI (2.1 bar) maximum.



WARNING



Risk of an electrical shock!

When wiring electrically driven pumps, follow all electrical and safety codes, as well as the most recent National Electrical Code (NEC) and the Occupational Safety and Health Act (OSHA).

Make certain the power source conforms to the pump voltage. Be sure all power is disconnected before installation.

The pump should be wired into an individual (dedicated) circuit, controlled with an UL/C-UL certified double pole switch rated at or above the fuse ampere indicated on the pump motor label.

On 115-volt AC pumps, the black wire lead is live or common, the white lead wire is neutral and the green/yellow is ground. On 230-volt AC pumps the brown wire lead is live or common, the blue wire is neutral and the green/yellow is ground.

On 12 and 24 volt DC pumps, the red lead is positive and should be connected to the battery plus (+) terminal. The black lead is ground and should be connected to the battery minus (-) terminal. Use 14 AWG wire minimum. Use a 10-15 amp fuse to protect the system wiring and components.

Improper duty cycle and/or rapid start stop conditions caused by undersized spray nozzles will cause the internal thermal breaker (if equipped) to trip, or can cause premature motor failure due to excessive heat.



WARNING



DO NOT USE TO PUMP FLAMMABLE FLUIDS, GASOLINE, KEROSENE FUEL OIL, ETC. DO NOT USE PUMP IN A EXPLOSIVE ENVIRONMENT.

Dimensional

Drawing

Inches (Millimeters)
Dimensional tolerances
± 0.06 inches
Consult factory if precise
details are required.

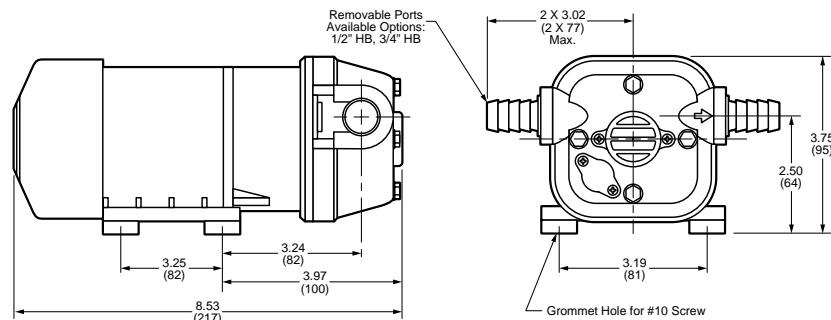

Model 4100 Industrial Series "Quad" Pump

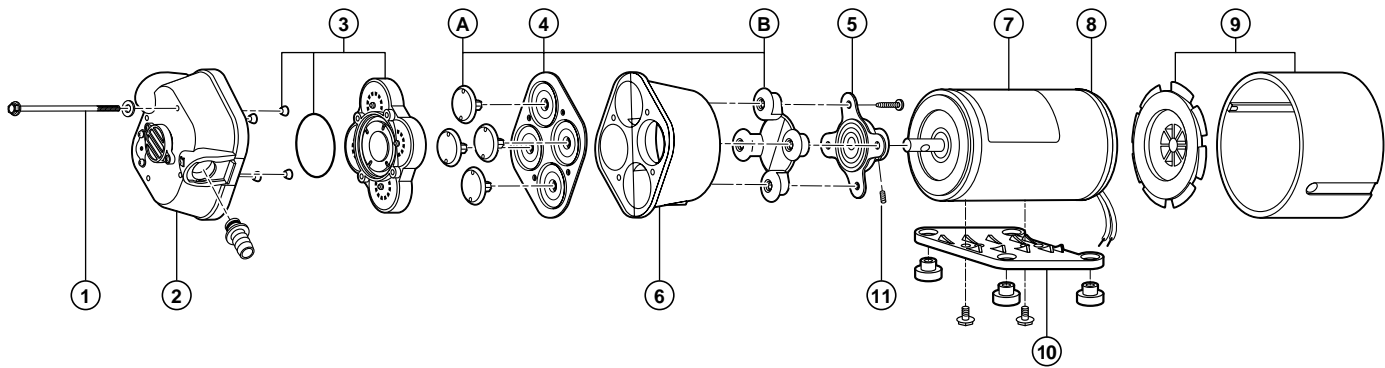

KEY	DESCRIPTION	KEY	DESCRIPTION
1	Pump Screws w/Washer & Ferrules	6	Bearing Cover
2	Upper Housing Assembly	7	Motor Assembly
3	Check Valve Assembly w/"O" Ring & Ferrules)	8	Motor Rear End Bell Assembly
4	Diaphragm w/Pistons & Screws	9	Fan/Shroud Assembly (If required)
5	Cam Bearing w/Set Screw	10	Base Plate/Grommet Assembly

SERVICE TIPS

DISASSEMBLY Remove four pump head screws (1). Rotate bearing cover (6) so drain notch is aligned with cam/bearing assembly set screw (11). Loosen set screw with 1/8" allen wrench and slide pump head off shaft. Always use complete FLOJET repair kits upon reassembly.

ASSEMBLY Install new single-piece outer piston (B) into lower housing (6) with piston tops pointing away from motor. Slightly bend outer piston (B) along premolded crease to aid assembly. Place diaphragm in lower housing (6) with the molded o-ring seals facing away from motor. Insert each inner piston (A) through diaphragm into outer piston. Turn each piston until fully seated. Align cam/bearing assembly (5) with outer piston (B). Secure with cam/piston screws using 18 inch pounds of torque. Reassemble lower housing (4, 5, 6) to motor. Set screw **MUST** be positioned over shaft indentation and secured tightly.

Reassemble pump upper housing (1, 2, 3). Check that ferrules are installed in upper housing and O-ring is properly seated before inserting check valve assembly (3) into upper housing (2). Align pump assembly to motor and tighten pump head screws evenly with 25 inch pounds of torque.

SERVICE KITS

Kits are readily available to repair standard Duplex II series pumps. To insure that the correct kits are received the model number and all name plate data must be included with the order. Contact a FLOJET distributor or FLOJET directly to order the necessary repair kits.

PRODUCT WARRANTY

Flojet warrants this product to be free of defects in material and/or workmanship for a period of one year after purchase by the customer from Flojet. During this one year warranty period, Flojet will at its option, at no charge to the customer, repair or replace this product if found defective, with a new or reconditioned product, but not to include costs of removal or installation. No product will be accepted for return without a return material authorization number. All return goods must be shipped with transportation charges prepaid. This is only a summary of our Limited Warranty. For a copy of our complete warranty, please request Form No. 100-101.

TROUBLESHOOTING

Failure to Prime - Motor operates, but no pump discharge

- Restricted intake or discharge line. Open all line valves, check for "jammed" check valves, and clean clogged lines.
- Air leak in intake line.
- Punctured pump diaphragm.
- Defective pump check valve.
- Crack in pump housing.
- Debris in check valves.

Motor Fails to Turn On

- Pump or equipment not plugged in electrically.
- Loose wiring connection.
- Pressure switch failure.
- Defective motor or rectifier.
- Frozen cam/bearing.

Pump Fails to Turn Off after Discharge valves are Closed

- Depletion of available liquid supply.
- Punctured pump diaphragm.
- Discharge line leak.
- Defective pressure switch.
- Insufficient voltage to pump.
- Debris in check valves.

Low Flow and Pressure

- Air leak at pump intake.
- Accumulation of debris inside pump and plumbing.
- Worn pump bearing (excessive noise).
- Punctured pump diaphragm.
- Defective rectifier or motor.
- Insufficient voltage to pump.

Pulsating Flow - Pump Cycling On and Off

- Restricted pump delivery. Check discharge lines, fittings, valves and spray nozzles for clogging or undersizing.

RETURN PROCEDURE

Prior to returning any product to Flojet, call customer service for an authorization number. This number must be written on the outside of the shipping package. Place a note inside the package with an explanation regarding the reason for return as well as the authorization number. Include your name, address and phone number.

Flojet



ITT Industries
Engineered for life

U.S.A.
Flojet
20 Icon
Foothill Ranch, CA 92610-3000
Tel: (949) 859-4945
Fax: (949) 859-1153

UNITED KINGDOM
Jabsco/Flojet
Bingley Road, Hoddesdon
Hertfordshire EN11 0BU
Tel: +44 (0) 1992 450145
Fax: +44 (0) 1992 467132

CANADA
Fluid Products Canada
55 Royal Road
Guelph, Ontario N1H 1T1
Tel: (519) 821-1900
Fax: (519) 821-2569

JAPAN
NHK Jabsco Company Ltd.
3-21-10, Shin-Yokohama
Kohoku-Ku, Yokohama, 222
Tel: 045-475-8906
Fax: 045-475-8908

GERMANY
Jabsco GmbH
Oststrasse 28
22844 Norderstedt
Tel: +49-40-53 53 73-0
Fax: +49-40-53 53 73-11