

**WARNING: BEFORE SERVICING PUMP, TURN OFF PUMP AND DRAIN WATER FROM SYSTEM!!**

**Failure to Prime** - Motor operates, but no pump discharge

- Restricted intake or discharge line
- Air leak in intake line
- Punctured pump diaphragm (pump leaking)
- Crack in pump housing

**Motor Falls To Turn On**

- Loose wiring connection
- Pump circuit has no power
- Blown fuse or open thermal protector
- Pressure switch failure
- Defective motor

**Pulsating Flow** - Pump cycles on and off

- Restricted pump delivery. Check discharge lines, fittings and valves for clogging or undersizing.

**Pump Fails to Turn Off After All Fixtures Are Closed**

- Empty water tank
- Insufficient voltage to pump (low battery)
- Punctured pump diaphragm (pump leaking)
- Discharge line leak
- Defective pressure switch

**Low Flow and Pressure**

- Air leak at pump intake
- Accumulation of debris inside pump and plumbing
- Worn pump bearing (excessive noise)
- Punctured pump diaphragm (pump leaking)
- Defective motor

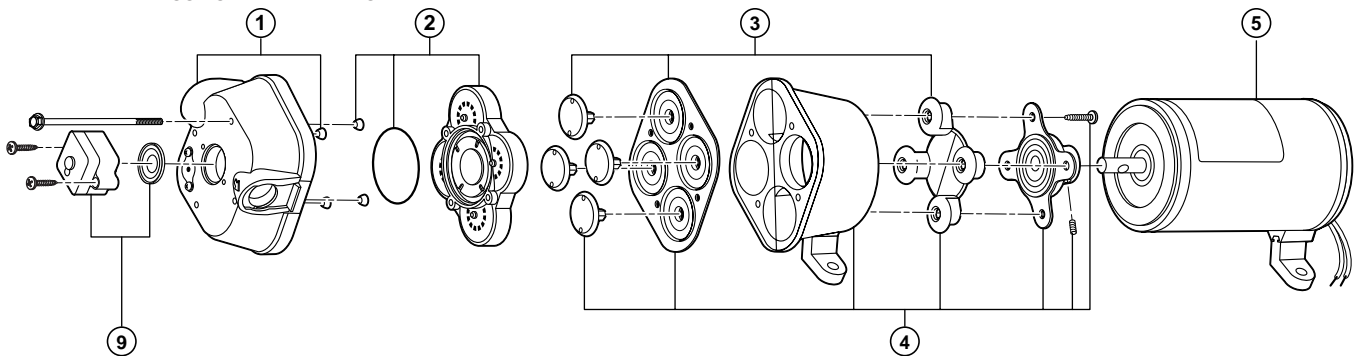

**DISASSEMBLE**

**Pressure Switch**

1. Remove switch (9). Disconnect switch wires.

**Upper Housing**

2. Loosen but do not remove four pump head screws and carefully remove upper housing assembly (1)
3. Inspect check valve (2) for debris
4. Reassemble new upper housing (1)

**Check Valve Assembly**

Follow steps 1

3. Replace check valve (2)
4. Reassemble upper housing (1)

**Lower Housing, Diaphragm, Motor**

Follow step 2

3. Rotate lower housing (4) so mounting notch opening on lower housing near baseplate exposes set screw which holds bearing housing to shaft.
4. Loosen this set screw by inserting wrench 1/8" Allen wrench into mounting notch opening. Then, slide lower housing (4) off motor shaft.

**Diaphragm Cont'd**

5. Loosen two cam piston screws with Phillips head screw driver and pull apart cam from inner pistons. (Pistons should always be replaced when a new diaphragm is installed.)

**Motor Cont'd**

5. Replace Motor

**REASSEMBLE**

**Motor**

1. Reassemble lower housing assembly (4) to motor. (Follow steps 4 to 10.)

**Diaphragm**

2. Lower housing is assembled with:

- Flat side of diaphragm and outer pistons facing motor
  - Hex stem of inner pistons must be aligned into hex holes in outer pistons (4).
  - Outer pistons must be aligned with alignment slots on cam assembly making sure screw holes align in cam assembly, otherwise diaphragm will leak.
3. Tighten cam piston screws partially, center piston in diaphragm, then tighten screws securely (18 in. lbs. torque)

**Lower Housing**

4. Reassemble lower housing assembly (4) to motor.
5. Retighten set screw securely. Set screw head must be positioned facing motor covering seam (indentation). (Positioning of this screw is critical to avoid misalignment and subsequent diaphragm damage.)

**Upper Housing, Check Valve**

6. Reassemble upper housing (1)
7. Properly seat O-Ring in check valve assembly (2) and check if ferrules and screen are in place on upper housing (1)
8. Install check valve (2) into upper housing (1) and push in.
9. Assemble on to lower housing (4), align 4 screws on to motor by rotating lower housing (4) if necessary.
10. Tighten screws evenly to 30 in. lbs. torque.

**Pressure Switch**

1. Place switch against front of pump (9), insert screws and take care not to cross thread or strip out threads in housing.
2. Reconnect wires.

---

## Flojet

---



**ITT Industries**  
*Engineered for life*

U.S.A.  
Flojet  
20 Icon  
Foothill Ranch, CA 92610-3000  
Tel: (949) 859-4945  
Fax: (949) 859-1153

UNITED KINGDOM  
Jabsco/Flojet  
Bingley Road, Hoddesdon  
Hertfordshire EN11 OBU  
Tel: +44 (0) 1992 450145  
Fax: +44 (0) 1992 467132

CANADA  
Fluid Products Canada  
55 Royal Road  
Guelph, Ontario N1H 1T1  
Tel: (519) 821-1900  
Fax: (519) 821-2569

JAPAN  
NHK Jabsco Company Ltd.  
3-21-10, Shin-Yokohama  
Kohoku-Ku, Yokohama, 222  
Tel: 045-475-8906  
Fax: 045-475-8908

GERMANY  
Jabsco GmbH  
Oststrasse 28  
22844 Norderstedt  
Tel: +49-40-53 53 73-0  
Fax: +49-40-53 53 73-11