

FLOJET®

“Triplex Diaphragm” 3406 Series Automatic Water System Pump With Internal Bypass Valve

Model 3406 Series

FEATURES

- Self-Priming
- Dry Running
- Soft, Noise Absorbing Mounts
- Corrosion Resistant Materials
- Meets ISO 8846
- Smooth Operation Without Accumulator Tank

SPECIFICATIONS

Motor: Permanent Magnet, Ball Bearing.
CE Models are fully suppressed.

Pump: Three chamber diaphragm design;
Self-priming up to 6 ft. suction lift;
Pump able to run dry without damage.

Note: The built-in bypass valve eliminates
the need for an accumulator tank.

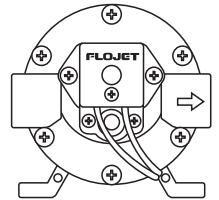
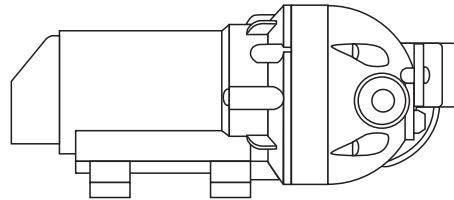
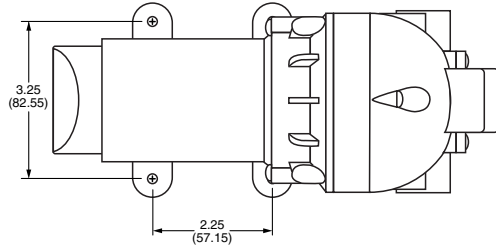

Pump Series	Dimensions - Inches (mm)			Weight lb. (kg)
	Height	Width	Length	
3406-XXX	3.65 (93)	4.0 (102)	8.9 (227)	3.9 (1.8)

MODEL*	VOLTS	AMP DRAW @ 10 psi (0.7 bar)	FLOW GPM (l/min)	PRESSURE SWITCH MAX psi (bar)
3406-143	12V dc	4.4	1.8 (6.8)	25 (1.7)

* CE fully suppressed models are identified by a prefix “R” and a CE mark on the label. (i.e. R3406-143).
Self Declaration Of Conformance (SDOC) is available upon request.

OPERATION

With pump switch off and battery fully charged, fill water tank, open all faucets, then turn pump switch on. Water will begin to flow. When water is free of air, turn faucets off. Remember, you are filling the water heater and the

toilet and shower lines. When all valves are shut off, pump will stop. Should pump fail to stop, turn switch off and see the trouble shooting guide.

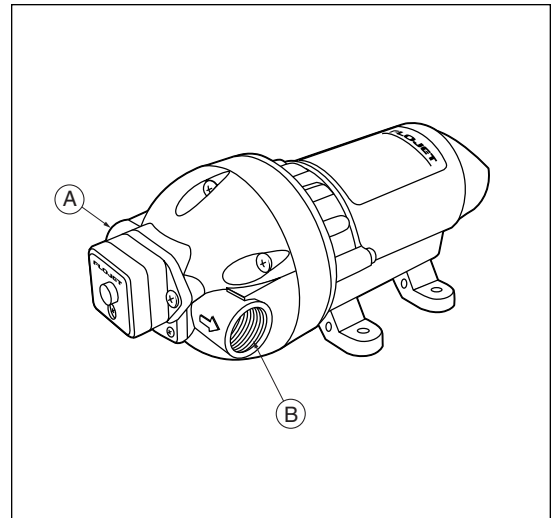
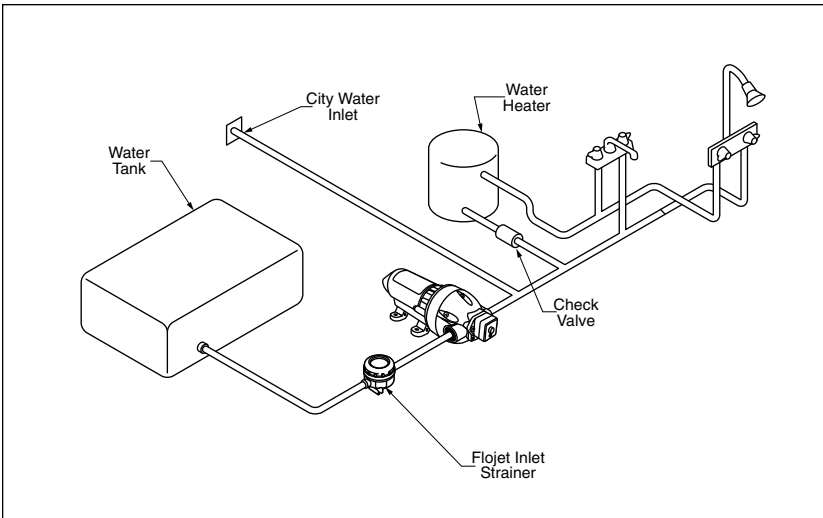

INSTALLATION

STEP 1

Remove shipping plugs from pump ports. Some water from factory testing may spill out.

STEP 2

Install inlet A and discharge B port adapters.

STEP 3

Rubber mounts must be fully inserted into 4 mounting tracks.

STEP 4

Mount pump vertically, with pump head down or horizontally in an accessible location. If mounting vertically, motor up, attach motor mounts while supporting weight of pump.

STEP 5

Use 3/8" (10 mm) or 1/2" (12 mm) I.D. flexible hose (preferably braided or reinforced). Use hose clamps on the slip-on barb hose connectors.

STEP 6

Install minimum 3/8" (10 mm) I.D. hose or piping for feed lines. Use high pressure hose on all city water lines.

STEP 7

Install a Flojet strainer in an accessible location (for inspection and cleaning) between the tank and pump inlet. This strainer or equivalent is required for pump warranty to be valid.

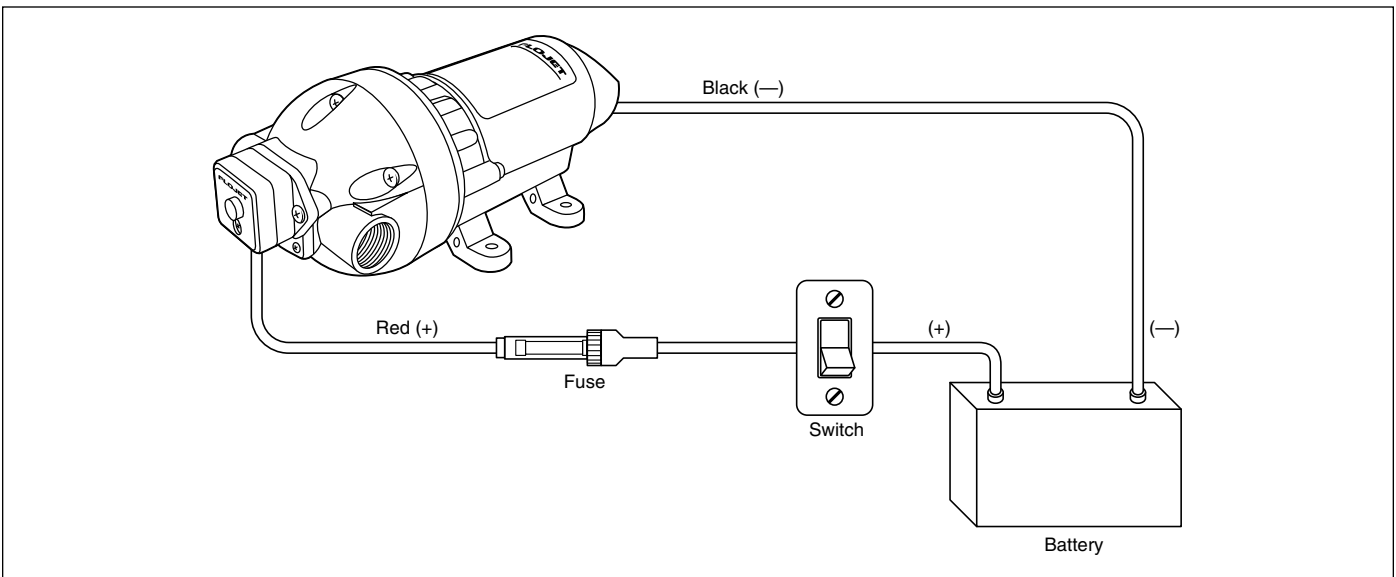

WIRING

STEP 1

Use 14 gauge stranded wire to 20', 12 gauge to 50', from power source.

STEP 2

Use a 7-10 amp rated on-off switch on the (+) positive (red) motor lead.

STEP 3

Install 7-10 amp fuse protection on the positive lead.

WARNING: BEFORE SERVICING PUMP, TURN OFF PUMP AND DRAIN WATER FROM SYSTEM!!

AUTOMATIC WATER SYSTEM PUMP SERVICE PARTS

KEY#	DESCRIPTION	MODEL# 3406-143	MODEL R3406-143
1	Pressure Switch Assembly 25 psi shut-off	02091-025	02091-025
2	Upper Housing With Switch	20404-029	20404-029
3	Check Valve Assembly	20407-032	20407-032
4	Lower Housing Assembly	20419-011	20419-011
5	Motor Adapter	20418-000	20418-000
6	Motors	02009-169A	—
	Motors CE Models		R2009-169A
7	Mounting Feet	20717-100A	20717-100A
8	Pump Head Assembly	20406-040A	20406-040A
9	Ports - 1/2" Barb (12 mm)	91010-006	91010-006
	Ports - 1/2"-14 (pipe)	91010-056	91010-056
	Ports - 3/8" Barb (10 mm)	91010-002	91010-002

*Service Kit includes #2, #3, #8 and drive cam assembly.

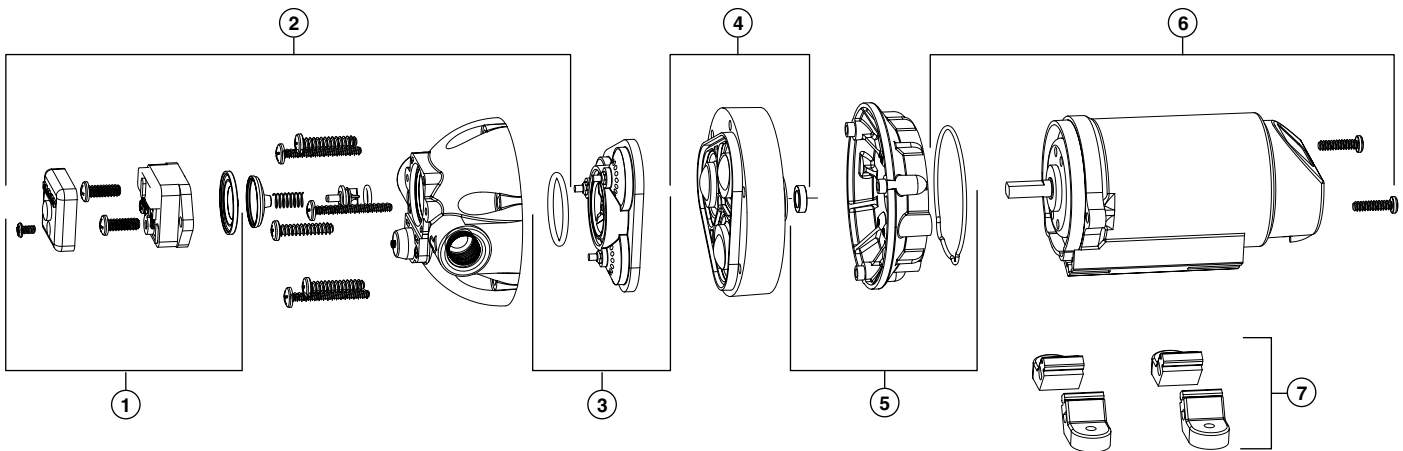

Quite often when a pump is worn or defective the one failed component has overburdened others. To avoid frequent aggravating repairs, Flojet offers service kit assemblies making complete repairs quick and easy.

DISASSEMBLE

Switch

1. Remove switch (1). Remove cover, disconnect switch wires.

Housing Assembly

2. Remove six pump head screws and carefully remove housing assembly (2-3-4)
3. Inspect check valve (3) for debris
4. Reassemble housing assembly (2-3-4)

Check Valve Assembly

Follow steps 2 and 3

3. Replace check valve (3)
4. Reassemble housing assembly (2-3-4)

Pump Head, Motor

Follow step 2

3. Slide lower housing (4) off motor shaft.

REASSEMBLE

Motor

1. Reassemble housing assembly (2-3-4) to motor. (Follow steps 4 to 10.)

Pump Head

2. Reassemble pump head housing assembly (2-3-4) to motor.

Housing, Assembly, Check Valve

3. Properly seat O-Ring in check valve assembly (3)
4. Install check valve (3) into housing (2) and push in.
5. Assemble on to lower housing (4), align 3 screws on to motor by rotating lower housing (4) if necessary to align.
6. Tighten screws evenly to 30 in. lbs. torque.

Pressure Switch

1. Place switch against front of pump (1), insert screws and take care not to cross thread or strip out threads in housing.
2. Reconnect wires, replace cover.

TROUBLESHOOTING

Failure to Prime - Motor operates, but no pump discharge

- Restricted intake or discharge line
- Air leak in intake line
- Debris in pump
- Punctured pump diaphragm (pump leaks)
- Crack in pump housing

Motor falls to turn on

- Loose wiring connection
- Pump circuit has no power
- Blown fuse
- Pressure switch failure
- Defective motor

Pulsating Flow

- Restricted pump delivery. Check discharge lines, fittings and valves for clogging or undersizing

Pump Fails to Turn Off After All Fixtures Are Closed

- Empty water tank
- Insufficient voltage to pump (low battery)
- Punctured pump diaphragm (pump leaks)
- Discharge line leak
- Defective pressure switch

Low Flow and Pressure

- Air leak at pump intake
- Accumulation of debris inside pump and plumbing
- Worn pump bearing (excessive noise)
- Punctured pump diaphragm (pump leaks)
- Defective motor

ACCESSORIES

QUICK CONNECT PORT SYSTEM

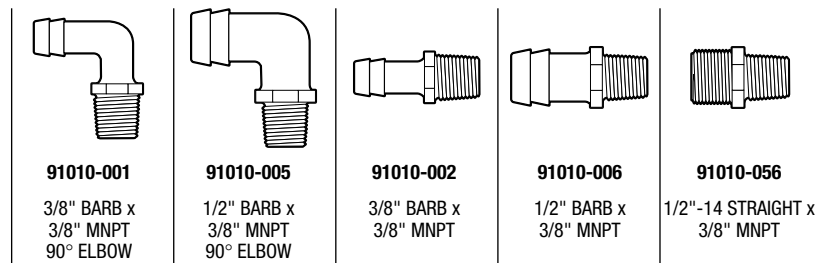

The above part numbers are packaged with 2 fittings per bag.

STRAINERS

Pump Series	Strainer Number	Inlet	Outlet	Screen
3406-XXX	1740-003	3/8" Barb	3/8" Barb	40 Mesh
	1740-002	1/2" Barb	1/2" Barb	40 Mesh
	1740-023	3/8" Barb	3/8" NPT (m)	40 Mesh

WARRANTY

FLOJET warrants this product to be free of defects in material and/or workmanship for a period of two years after purchase by the customer from FLOJET. During this two year warranty period, FLOJET will at its option, at no charge to the customer, repair or replace this product if found defective in material or workmanship, with a new or reconditioned product, but not to include costs of removal or installation.

RETURN PROCEDURE

Prior to returning any product to FLOJET, call customer service for an authorization number. This number must be written on the outside of the shipping package. Place a note inside the package with an explanation regarding the reason for return as well as the authorization number. Include your name, address and phone number.

Flojet



ITT Industries
Engineered for life

U.S.A.
Flojet
20 Icon
Foothill Ranch, CA 92610-3000
Tel: (949) 859-4945
Fax: (949) 859-1153

UNITED KINGDOM
Flojet, Unit 1, Avant Business Centre
Denbigh West Industrial Estate
Milton Keynes, Bucks, England MK1 1DL
Tel: +44 1908 370088
Fax: +44 1908 373731

CANADA
Fluid Products Canada
55 Royal Road
Guelph, Ontario N1H 1T1
Tel: (519) 821-1900
Fax: (519) 821-2569

JAPAN
NHK Jabsco Company Ltd.
3-21-10, Shin-Yokohama
Kohoku-Ku, Yokohama, 222
Tel: 045-475-8906
Fax: 045-475-8908

GERMANY
Jabsco GmbH
Oststrasse 28
22844 Norderstedt
Tel: +49-40-53 53 73-0
Fax: +49-40-53 53 73-11