

SERVICE PARTS KIT LIST

2130 SERIES

FLOJET®

Typical 2130 Series Assembly

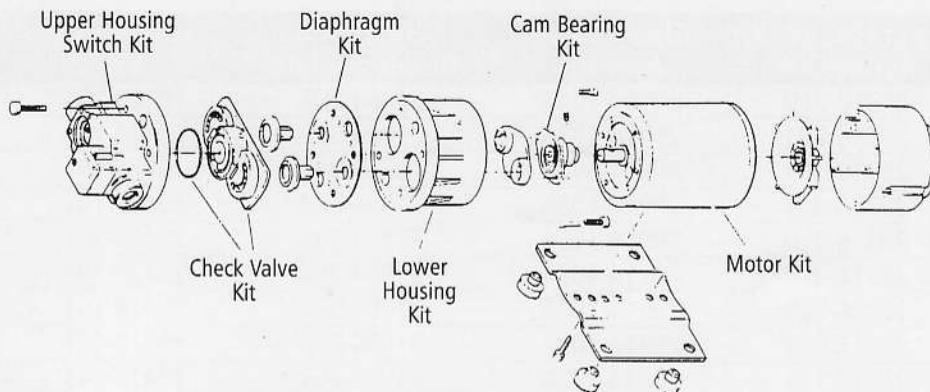

PARTS KIT DESCRIPTIONS

Switch Kit:

Complete pressure switch and upper housing assembly.

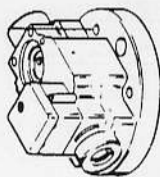

Check Valve Kit:

Check valve assembly with "O" ring.

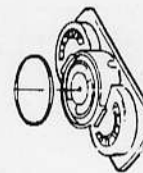

Bypass Kit:

Bypass poppets and springs, two each.

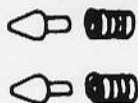

Cam/Bearing Kit:

Cam/bearing assembly with screw.

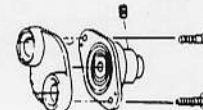

Diaphragm Kit:

Diaphragm with inner and outer pistons and screws.

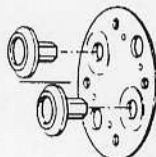

Lower Housing Kit:

Lower housing with cam, diaphragm and piston assembly.

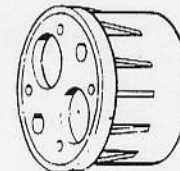

Motor Kit:

Complete motor assembly (includes fan and shroud).

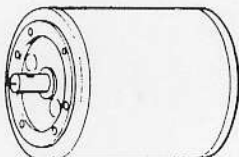

To find correct parts kits: Identify the pump model number in the left column and read across to the kit number required. If pump has a switch and bypass, both are shown in second column.

For individual parts not included in this list, please refer to your installation, operation and service instruction sheet for the particular pump model.



ITT

Engineered for life

2130 SERIES PARTS KIT LIST

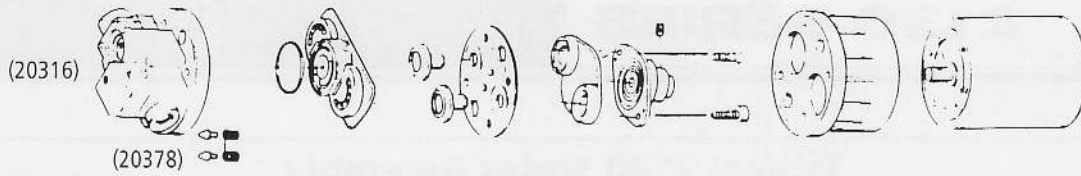

Model #	Upper Hsg SW Kit Bypass Kit	Check Valve Assy Kit	Cam Bearing Diaphragm Kit	Lower Hsg Kit	Motor
2130-012	20316-010	20914-101A	21004-202	20428-101	02029-021
2130-030	20316-003	20914-103A	21004-320	20428-101	02029-021
2130-032	20316-003	20914-103A	21004-302	20428-101	02029-021
2130-034	20316-003	20914-103A	21004-304	20428-101	02029-021
2130-112	20316-010	20914-101A	21004-202	20428-101	02009-027
2130-114	20316-010	20914-101A	21004-204	20428-101	02009-027
2130-131	20316-060	20914-103A	21004-321	20428-101	02009-027
2130-132	20316-060	20914-103A	21004-302	20428-101	02009-027
2130-212	20316-101	20914-101A	21004-202	20428-101	02039-027
2130-230	20316-060	20914-103A	21004-320	20428-101	02039-027
2130-312	20316-010	20914-101A	21004-202	20428-101	02019-006
2130-332	20316-003	20914-103A	21004-302	20428-101	02019-006
2130-517	20316-060	20914-103A	21004-320	20428-101	02029-021
2130-522	20316-003	20914-103A	21004-320	20428-101	02039-027
2130-529	20316-010	20914-101A	21004-221	20428-101	02029-021
2130-533	20316-060	20914-103A	21004-320	20428-101	02029-021
2130-546	20316-068	20914-103A	21004-321	20428-101	02039-039
2130-584	20316-090	20914-103A	21004-302	20428-101	02029-021
2130-598	20316-003	20914-102A	21004-321	20428-101	02019-001
2130-599	20316-003	20914-102A	21004-302	20428-101	02029-021

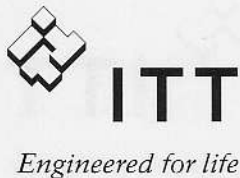

USA
Jabsco
Cape Ann Industrial Park
1 Kondelin Road
Gloucester, MA 01930
Tel: +1 976 281 0440
Fax: +1 976 283 2619

UK
Jabsco
Bingley Road, Hoddesdon
Hertfordshire EN 11 0BU
Tel: +44 1992 450145
Fax: +44 1992 467132

CANADA
Fluid Products Canada
55 Royal Road
Guelph, Ontario N1H 1T1
Tel: +1 519 821 1900
Fax: +1 519 821 5316

JAPAN
NHK Jabsco Co Ltd.
3-21-10, Shin-Yokohama
Kohoku-ku
Yokohama 222-0033
Tel: +81 045 475 8906
Fax: +81 045 477 1162

GERMANY
Jabsco GmbH
OststraBe 28
22844 Norderstedt
Tel: +49 40 5353 730
Fax: +49 40 5353 7311

ITALY
Jabsco Marine Italia
Via Tommaseo, 6
20059 Vimercate, Milano
Tel: +39 039 685 2323
Fax: +39 039 666 307

www.flojet.com