

PRODUCT DATA SHEET**12 Volt DC Rotary Vane Pump Series 1200C**

- [Description of Included Models](#)
- [Available Options](#)
- [Safety Listings](#)
- [Accessories](#)
- [Performance](#)
- [Flow Curve](#)
- [Fluid Compatibility](#)
- [Dimensions](#)
- [Repair](#)
- [Maintenance](#)
- [Frequently Asked Questions](#)



Model 1210C Battery Powered Pump Shown

Description of Included Models

Model Number	Description	Shipping Weight
FR1205C	Basic 12 volt DC pump with 15' of battery cable	22 lbs 10.0 kgs
FR1210C	Basic 12 volt DC pump with 15' of battery cable, hose & nozzle and telescoping suction pipe	33 lbs 15.0 kgs
FR1211C	Basic 12 volt DC pump with 15' of battery cable, hose & nozzle, telescoping suction tube and Model 807C meter installed	39 lbs 17.7 kgs
FR2410C	Basic 24 volt DC pump with 15' of battery cable, hose & nozzle and telescoping suction pipe	15 lbs 6.8 kgs
FR2411C	Basic 24 volt DC pump with 15' of battery cable, hose & nozzle, telescoping suction pipe and Model 807C meter installed	15 lbs 6.8 kgs

[\[back to data sheet index\]](#)

Safety Listings

Approval Organization Mark	Organization Description	File Number	Guide Number
	Underwriters Laboratories Inc. , a nationally recognized Independent organization for testing of products to ensure public safety.	MH7817	RCRX



Indicates compliance with applicable European standards.

N/A

N/A



Australian Certification Program, Series 1200B(12V, 49 LPM) and Series 2400B (24V, 49 LPM) certified on Aus EX 3620.

N/A

N/A

[\[back to data sheet index\]](#)

Available Options

Option	Description	Adjustment to Shipping Weight (lbs.)	Adjustment to Shipping Weight (kgs.)
A	Upgrade to automatic nozzle from standard manual nozzle	2.0	.9
L	Unit equipped with meter registering liters in place of standard gallon meter	-	-
-X001	Unit supplied less hose	(5.0)	(1.4)
-X002	Unit supplied less telescoping suction tube	(2.0)	(0.9)
-X003	Unit supplied less nozzle	-	-
-X005	Unit supplied less hose and nozzle	(6.0)	(2.7)

[\[back to data sheet index\]](#)

Accessories

Part Number	Description
4200F9111	Nozzle Spout Hook (for automatic nozzles)
700F3135	Buna N hose - 3/4" X 12' with static wire and 3/4" ferrules
1200KTG9099	Telescoping steel suction pipe - 1"NPT threads - Extends 22" to 40"
6U075	Manual unleaded nozzle with 3/4" inlet
N075UAU10	Automatic unleaded nozzle with 3/4" inlet
400F6634	Wall mount bracket for this pump
1200KTF7018	Particulate Filter Kit - 700ACCF7016 cast iron 3/4" adapter with 700ACCF7013 filter for Model 1210B
1200KTF7019	Hydrosorb Filter Kit - 700ACCF7016 cast iron 3/4" adapter with 700ACCF7012 filter for Model 1210B

[\[back to data sheet index\]](#)

Performance

Maximum outlet pressure	12 PSI (1.10 BAR)
Maximum flow rate (1)	13 GPM (53 LPM)
Maximum Recommended Viscosity of Pumped Fluid	Diesel Fuel
Maximum ambient operating temperature	150 °F (66 °C)*
Minimum ambient operating temperature	-15 °F (-26 °C)*
Minimum Dry Vacuum	6 Inches of mercury
Minimum Suction Lift**	8 feet for diesel & see below for gasoline***

1) Nominal flow rate at nominal voltage using a standard hose and manual nozzle with low viscosity fluid.

* Consult factory for extreme temperature applications outside this range.

** The lift in feet is equivalent to the vertical distance from the surface of the fluid in the tank to the inlet of the pump, PLUS the friction losses through the vertical and horizontal runs of pipe. All elbows and other fittings must be included in the calculation of friction loss. The system should be designed to require a minimum amount of suction lift.

*** Lift of gasoline dependent on Reid's vapor pressure of the gasoline and it's temperature. The lower the vapor pressure and temperature, the higher the possible lift.

[\[back to data sheet index\]](#)

Flow Control

A - FR1205C
with 807C
Meter (no
nozzle or
hose).

B - FR1210C
with 12' of
3/4" hose
and manual
nozzle.

C - FR1211C
with 12' of
3/4" hose
and manual
nozzle.

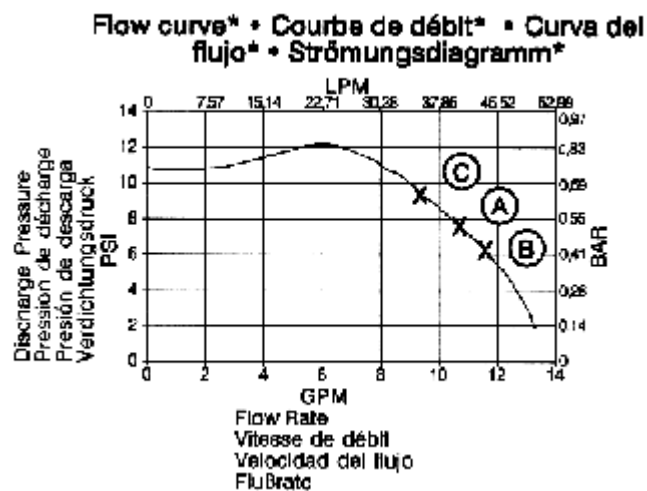

* Nominal flow curves for reference only. Based on 3 feet of suction lift. Actual flow rate may vary.

[\[back to data sheet index\]](#)

Fluid Compatibility

The Series 100 Rotary Hand Pumps are designed for petro products of all types. If there is a question for a particular fluid, check the affects of that fluid on the following wetted materials.

Cast Iron	Steel	Stainless Steel
Bronze/Iron	Carbon	Polyester
Aluminum	Cork/Buna N	Buna N
Ceramic	Fiber	Zinc Plated Steel
Acetal	Fluourocarbon (All Pumps)	PPS (1211B & 2411B Only)

[\[back to data sheet index\]](#)

Dimensions

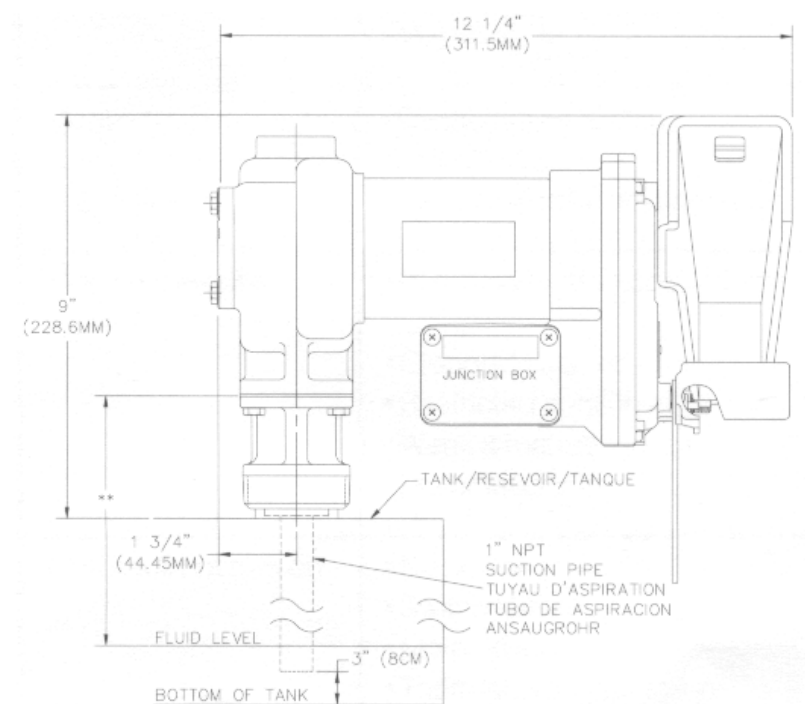

External threads in bung adapter are designed to fit the standard 2" NPT bung found on most barrels and tanks.

[\[back to data sheet index\]](#)

Repair

To maintain UL listing, motors that need repair must be taken to an authorized repair shop for service. Pumps must be thoroughly flushed and drained before being taken in for service.

[\[back to data sheet index\]](#)

Maintenance

To keep the pump running at its best, periodically perform the following procedures:

1. Remove and clean the strainer screen, after every 20 hours of operation. The Cleaning frequency depends on the cleanliness of the fluid being pumped.
2. Thoroughly flush pumps to be stored for any extended periods of time with diesel fuel or kerosene.

See the meter's Owner's Operation & Safety Manual for recommended maintenance procedures.

[\[back to data sheet index\]](#)

Frequently Asked Questions

The questions below are linked to the answers for that particular question. Point and click on the question of interest and you will be move to the answer to that question. Buttons are provided to allow you to move back to this question list or to the original INDEX.

1. [My pump only pumps for a few minutes and then stops. What is happening?](#)
2. [There is fluid coming out of the small hole in the pump body. How do I stop it?](#)
3. [Why do I have to use the heavy wire supplied with the pump for connection to my battery?](#)
4. [Why are battery clips not provided with or on the wires, to connect to the battery?](#)

1. My pump only pumps for a few minutes and then stops. What is happening?

Generally "short cycling" indicates the motor is drawing too much current from the power source for some reason, and the thermal relay is opening to protect the insulation from the resulting heat build up. If this is what is happening, the thermal relay will reset after 10 to 20 minutes and the motor will again operate. The causes of high current are many. The pump is designed for low viscosity fluid, like diesel or gasoline, and will overheat if used to pump oil or other higher viscosity fluids. The inlet filter screen could be clogged. Bearings could be defective resulting in a drag on the armature shaft rotation.

See the Troubleshooting Guide in your Owner's Manual packed with your unit or the copy available in the Reference Documents section of this More Info page for things to check.

[\[back to data sheet index\]](#)

[\[back to FAQ's\]](#)

2. There is fluid leaking out of the small hole in the bottom of the pump body. How do I stop it?

This small hole is the "weep hole" and is positioned to drain fluid that has leaked past the dynamic seal between the pump and the motor. It is important that the leak be corrected as soon as possible to avoid damage to the front motor bearing. The problem could be as simple as foreign materials preventing the ceramic and carbon seal components from being in intimate contact, to as complex as a defective o-ring or casting.

See the Troubleshooting Guide in your Owner's Manual packed with your unit or the copy available in the Reference Documents section for things to check.

[\[back to data sheet index\]](#)

[\[back to FAQ's\]](#)

3. Why do I have to use the heavy wire supplied with the pump for connection to my battery?

Your pump is a commercial grade unit and as such draws a high current from your battery to do the work required. If that current were routed through a light wire, heating and possible damage of the wire and reduced voltage at the pump would be the result. The wire supplied with your pump is sized to provide that optimum performance you demand and the pump can provide, if properly installed.

It is also recommended a 30 amp fuse be installed in the power line to insure safety, should a short circuit develop in the pump wiring. Although the pump requires less than 20 amps in normal operation, motor starting currents are significantly higher, necessitating the higher rating on the fuse.

[\[back to data sheet index\]](#)

[\[back to FAQ's\]](#)

4. Why are battery clips not provided with or on the wires, to connect to the battery?

It is not recommended that the electrical connections for this level of electrical current be made through battery clips of the type normally found on battery chargers. This type of connection often results in electrical losses and heating at the clips. This in turn could lead to arcing in the proximity of the battery where an explosive mixture including hydrogen gas is often present as a result of the normal charging and discharging of the battery.

It is recommended that the wires be crimped or firmly bolted to the battery terminals to avoid the risk noted.

[\[back to data sheet index\]](#)

[\[back to FAQ's\]](#)