

PRODUCT DATA SHEET**Series 100 Rotary Hand Pump**

- [Description of Included Models](#)
- [Available Options](#)
- [Safety Listings](#)
- [Accessories](#)
- [Performance](#)
- [Fluid Compatibility](#)
- [Dimensions](#)
- [Repair](#)
- [Maintenance](#)
- [Frequently Asked Questions](#)



Model 100 Rotary Hand Pump Shown
FILL-RITE

Description of Included Models

Model Number	Description	Change in Shipping Weight
110	Basic UL Listed pump with Vacuum Breaker	10 lbs 4.5 kgs
112	Basic UL Listed pump with Vacuum Breaker, 8' Hose & Nozzle, 2" Bung Adapter(1" inlet) and Telescoping suction tube	17 lbs 7.7 kgs
113	Basic UL Listed pump Basic UL Listed pump with 2" Bung Adapter(1" inlet), Telescoping suction tube and Spout	16 lbs 7.3 kgs
114	Basic UL Listed pump with 2" Bung Adapter(1" inlet), Telescoping suction tube, Spout and Drip Pan	18 lbs 8.2 kgs

[\[back to data sheet index\]](#)

Safety Listings

Approval Organization Mark	Organization Description	File Number	Guide Number
	Underwriters Laboratories Inc. , a nationally recognized Independent organization for testing of products to ensure public safety.	MH6988	EVRZ

[\[back to data sheet index\]](#)

Available Options

Option	Description	Shipping Weight (lbs.)	Shipping Weight (kgs.)
113	Rotary pump equipped with Model 111 counter kit.	11.0	4.54
L	Basic unit supplied with liter measure for Series 100	-	-
-X001	Unit supplied less hose	(3.0)	(1.4)
-X002	Unit supplied less telescoping suction tube	(2.0)	(0.9)
-X003	Unit supplied less nozzle	-	-
-X004	Unit supplied less spout	(2.0)	(0.9)
-X005	Unit supplied less hose and nozzle	(3.0)	(1.4)

[\[back to data sheet index\]](#)

Accessories

Part Number	Description
5200F1790	Hand pump Nozzle
5200F1619	Discharge spout
5200F1750	Hose - 5/8" X 8' with 3/4" ferrules
100ACC111	Counter kit
100F0842	Barrel bung adapter
400F6634	Wall mount bracket for this pump
100F1189	Telescoping steel suction pipe extends from 22" to 40"
VP172F8617	Suction tube upper section - 17" female to female ends
VP172F6834	Suction tube lower section - 17" male end to 15° cut end
VP62F9091	Steel 1" X 8" nipple to attach suction tube sections to pump
7000KTF7183	Particulate filter kit
7000KTF7186	Hydrosorb filter kit

[\[back to data sheet index\]](#)

Performance

Flow Capability	10.3 Ounces (0.306 Liters) per Revolution.
Maximum Dry Vacuum	6" of Mercury
Minimum Lift**	8' of Diesel. For gasoline see below.
Maximum Viscosity of fluid pumped	SAE30 Motor Oil
Maximum ambient operating temperature	150 °F (66 °C)*

Minimum ambient operating temperature -15 °F (-26 °C)*

* Consult factory for extreme temperature applications outside this range.

** The lift in feet is equivalent to the vertical distance from the surface of the fluid in the tank to the inlet of the pump, PLUS the friction losses through the vertical and horizontal runs of pipe. All elbows and other fittings must be included in the calculation of friction loss. The system should be designed to require a minimum amount of suction lift.

*** Lift of gasoline dependent on Reid's vapor pressure of the gasoline and it's temperature. The lower the vapor pressure and temperature, the higher the possible lift.

CAUTION: Only pump as clearly carrying the UL Listing Mark should be used with gasoline or any low flashpoint fluid. Look for the Mark.

[\[back to data sheet index\]](#)

Fluid Compatibility

The Series 100 Rotary Hand Pumps are designed for petro products of all types. If there is a question for a particular fluid, check the affects of that fluid on the following wetted materials.

Cast Iron Steel Zinc Plated Steel
Acetal Viton® Vellumoid

Also

Nylon-110, 120, 112, and 122 Only

[\[back to data sheet index\]](#)

Dimensions

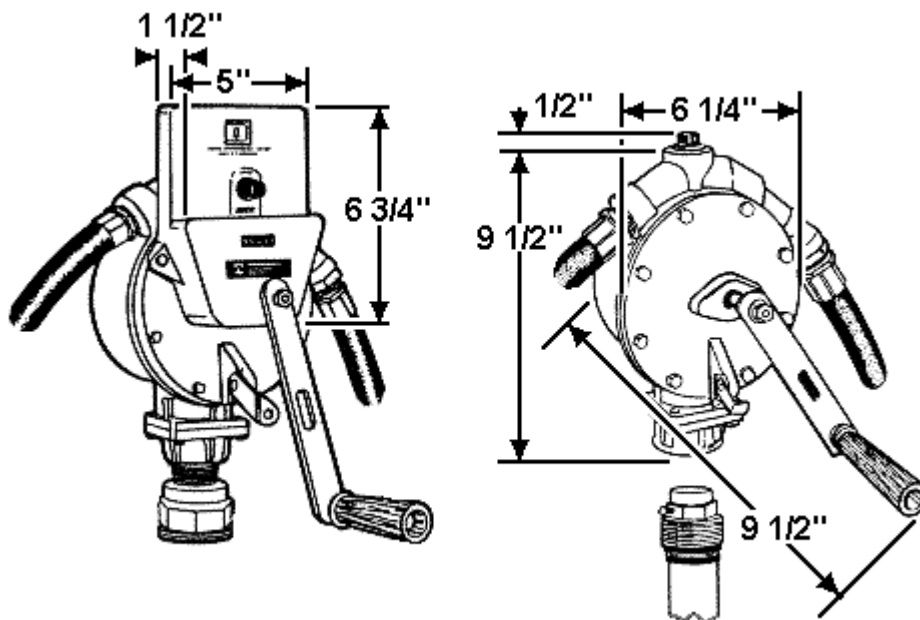

[\[back to data sheet index\]](#)

Repair

The Series 100 rotary hand pumps is designed for long years of trouble free service. A number of the more common situations that have been noted are included in the frequently asked questions. If it becomes necessary to take your pump to a service center, always thoroughly flush with a compatible solvent, water for water based fluids and kerosene or diesel fuel for petro products, before packing.

Refer to the Parts and Technical Service Guide packed with the new pump for additional service and repair ideas.

[\[back to data sheet index\]](#)

Maintenance

To keep the pump running at its best, periodically perform the following procedures:

1. Thoroughly flush using a compatible solvent, kerosene or diesel fuel, if the pump is to be stored unused for any period of time.
2. if leakage is noted around piston shaft, tighten packing nut in 1/4 turn increments until leakage stops. Over tightening will make pumping more difficult than is necessary.

[\[back to data sheet index\]](#)

Frequently Asked Questions

The questions below are linked to the answers for that particular question. Point and click on the question of interest and you will be move to the answer to that question. Buttons are provided to allow you to move back to this question list or to the original INDEX.

1. [My pump is leaking between the cover and the casting. What should I do?](#)
2. [The pump capacity is MUCH less than when the pump is new. What's going on?](#)
3. [Fluid is squirting out of the square headed fitting in the pump casting top. How do I stop it?](#)
4. [I have to crank for quite a while before any fluid comes out. What is wrong?](#)

1. My pump is leaking between the cover and the casting. What should I do?

First try tightening the four tie bolts 1/4 turn. Use EXTREME caution as over tightening of these bolts can break the casting. If tightening does not stop the leaking remove the bolts and examine the o-ring in the casting channel and the cylinder edge for damage. A new o-ring may be required. See the parts listing in the Service Guide for the part number of the gasket.

[\[back to data sheet index\]](#)

[\[back to FAQ's\]](#)

2. The pump capacity is MUCH less than when the pump is new. What's going on?

The pump is either developing much less vacuum then when new, there is an obstruction in the flow path or there is a leakage in the suction causing air to replace liquid. Remove the four bolts attaching the pump body to the inlet flange and remove the pump body. Check to insure the inlet filter screen is not clogged restricting flow. Rotate the handle while holding your palm over the pump inlet, sensing the level of vacuum developed. Little or no vacuum would indicate worn parts preventing the full vacuum from being developed. Install the repair kit F1214 and retest. Significant vacuum would indicate blockage or a leak in the inlet. The blockage or leak must be located and corrected.

[\[back to data sheet index\]](#)

[\[back to FAQ's\]](#)

3. Fluid is squirting out of the square headed fitting in the pump casting top. How do I stop it?

That "fitting" is the Vacuum Breaker and a critical component of your pumps safety system. Should the hose and nozzle fall on the ground while full of fluid, a siphon action could be established. This could drain the entire tank on which the pump is installed. The Vacuum Breaker is a one way valve which closes when fluid is being pumped. If a vacuum develops in the pump, do to a siphoning action, it allows the entry of air preventing fluid from being drawn out of the tank. If fluid is "squirting" out when pumping, the valve is leaking. Either dirt is preventing the valve from closing or the valve is defective and should be replaced. In either case remove the vacuum breaker and check for dirt or damage. If damaged the vacuum breaker must be replaced with the matching replacement.

[\[back to data sheet index\]](#)

[\[back to FAQ's\]](#)

4. I have to crank for quite a while before any fluid comes out. What is wrong?

The situation described sounds like a condition normally described as "loss of prime". The check valve is designed to keep fluid in the inlet piping and pump inlet when the pump is not being operated. This insures that fluid flows almost immediately when the pump handle is rotated. If that valve is leaking or there is a leak somewhere in the inlet system, fluid will drain back into the tank., and "prime" will be lost. The valve should be cleaned and carefully examined for proper functioning and/or the leak in the inlet piping located and repaired.

[\[back to data sheet index\]](#)

[\[back to FAQ's\]](#)