

# Edson Models 638AL Bottom Inlet Lever Action Manual Pumps

## Operation & Parts Manual

638AL-200 Bone Dry Manual, Bottom Inlet, Lever Action, Diaphragm Pump, Aluminum, 2" Inlet & Discharge  
638AL-150 Bone Dry Manual, Bottom Inlet, Lever Action, Diaphragm Pump, Aluminum, 1 1/2" Inlet & Discharge

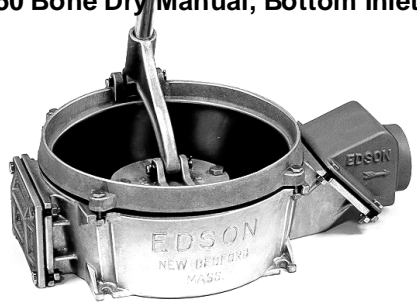

### Caution

Special Applications - Edson pumps are used for many diverse applications. Some may require special parts or maintenance procedure. i.e.. pumping liquid with gasoline or other fuels requires using Viton diaphragms and valves. If you have any questions regarding procedures for your application, call Edson customer service.

## 1. Installation Guidelines

### Installing the Pump

1. Install the pump in a manner that allows for a comfortable position for pumping and easy access for inspection and maintenance.
2. The head ring and drive arm can be rotated to the four 90 degree positions allowed by the square bolt pattern. (Fig 5 Page 2)
3. The pump is designed to be installed on a relatively horizontal surface using 1/4 " bolts or screws at the four corners of the base (Fig 5). If the mounting surface can not be horizontal, the inlet port should be lower than the discharge.
4. Do not combine incompatible metals i.e.. **no aluminum fittings on a bronze pump or bronze fittings on an aluminum pump.**
5. Check that all nuts and bolts are tight (Fig 5). Requires two 7/16 and one 9/16 box wrenches.

### Installing the Plumbing

1. Fittings and hose couplings must be air tight. Threads must be sealed with pipe sealer.
2. To avoid clogging plumbing on the discharge should be the same size or larger than the inlet.
3. Connect plumbing to the pump using unions or easily removed couplings.
4. For sewage and sump applications using backup check valves on the inlet and discharge will improve the ability of the pump to dry prime.
5. For sewage and sump applications where the discharge drains naturally down and away from the pump installing a positive loop will improve the self priming feature. When you stop pumping the loop traps some liquid against the discharge valve improving the seal. Fig. 1
6. When discharging to a point higher than the pump, install the discharge plumbing so that no air can be trapped in the plumbing. Fig. 2 & 3. Trapped air restricts the flow of liquid and requires more work to pump liquid past the air lock.
7. If the pump is being installed to pump liquids with suspended solids and the use will be intermittent, solid matter can get trapped under the check valves. This will prevent self priming at the next use. Flushing with water will generally clear out the solid matter. Installing secondary clear flapper check valves right at the inlet and discharge will improve the dry suction start performance of the pump. Order Edson Clear Check Valves 269CL-200 for 2" or 269CL-150 for 1 1/2"

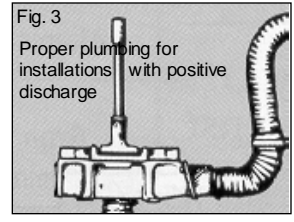
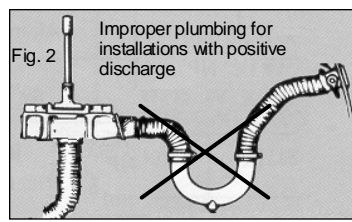
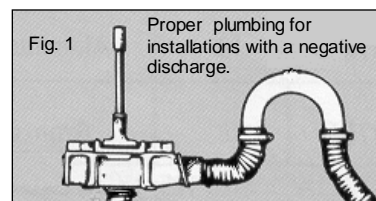

## 2. Operation

### The Pump Works By:

1. Pulling back on the handle raises the diaphragm creating a vacuum .
2. The vacuum pulls the discharge valve assembly closed.
3. Atmospheric pressure pushes liquid up the inlet plumbing to fill the vacuum.
4. Pushing forward on the handle compresses the air and liquid under the diaphragm closing the inlet check valve and forcing the air and liquid out the discharge.
5. The closing of the inlet valve assembly prevents the liquid and air trapped in the inlet line from dropping back to atmosphere.

### Pump Performance Depends On:

1. An air tight diaphragm.
2. Valve assemblies that seal well on the pump inlet and discharge valve seats.
3. Inlet plumbing that is air tight all the way to the point it is submersed in the liquid.

Inlet Valve Assembly:  
opens into the pump  
Discharge Valve Assembly:  
closes and seals on the valve seat that is part of the pump base under the discharge chamber.

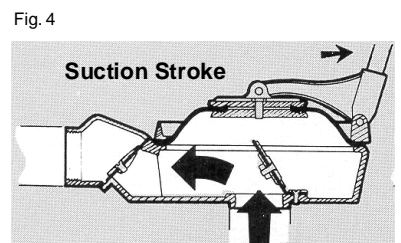

Discharge Valve Assembly:  
opens away from the pump  
Inlet Valve Assembly:  
closes and seals on the valve seat that is part of the inlet chamber.

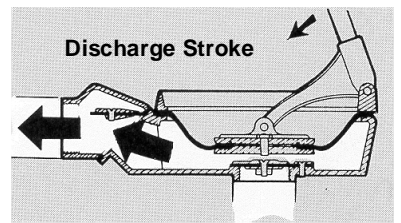

### 3. Parts List

Fig. 5

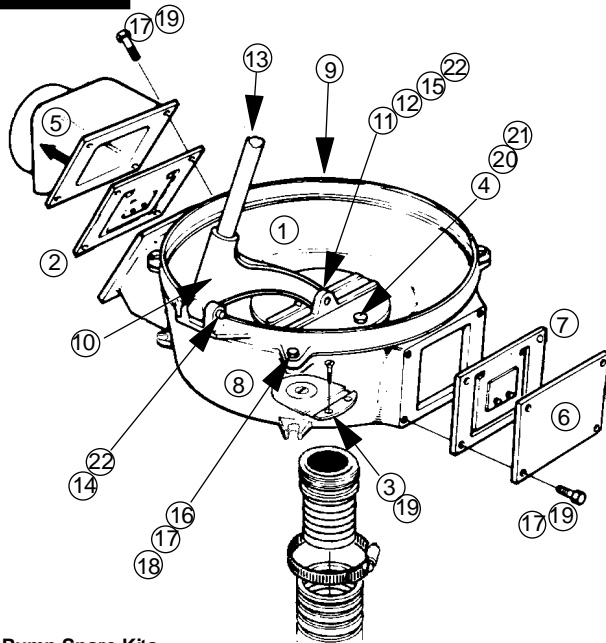

#### 638AL-200 Parts

Key #	Part No.	Description	Qty
1	113H-0	Size 0 Diaphragm - Hypalon	1
2	160-G-107	Bone Dry Pump Valve Assembly - Hypalon	1
3	160-G-108	Bone Dry Pump Valve Assembly - Hypalon	1
4	160-A-1200	3/8" Sealing Washer - Stainless	2
5	160-B-50A-200	2" Discharge Chamber- Alum.	1
6	160-A-730	Inspection Plate- Alum.	1
7	160-A-21	Sealing Rubber	1
8	160-C-190	Bottom Inlet Pump Base - Alum.	1
9	160-C-4A	Heading Alum.	1
10	160-B-28A	Drive Arm - Alum.	1
11	160-A-1A	Upper Standard - Alum.	1
12	160-A-906	Lower Standard -Stainless	1
13	160-A-41	32" Pump Handle with Grip	1
14	160-A-53	Head Ring Pivot Pin	1
15	160-A-54	Standard Pivot Pin	1
16		1/4-20 X 1.5 HHCS Stainless	4
17		1/4-20 Nut Stainless	12
18		1/4" Lock Washer	4
19		1/4-20 X 1" HHCS Stainless	10
20		3/8" Lock Washer	2
21		3/8-16X1" HHCS Stainless	2
22		1/8" X 3/4" Cotter Pin Stainless	4

#### 638AL-150 Parts are the same as above except for the following:

Key #	Part No.	Description	Qty
4	160-B-50A-150	1 1/2" Discharge Chamber - Alum.	1
21	160-A-97	1 1/2" x 2" Reducer Bushing PVC	1

#### Optional Parts substituted upon request:

Key #	Part No.	Description
1	113V-0	Size 0 Diaphragm -Viton
2	160-G-107V	Bone Dry Pump Valve Assembly - Viton
3	160-G-108V	Bone Dry Pump Valve Assembly - Viton
13	160-A-41ST	32" Pump Handle Stainless 304 with Grip

#### Bone Dry Pump Spare Kits

Size 0  
10.5"

113H-0

A-1200

**Bone Dry Bottom Inlet Hypalon Pump Spares Kit**  
Order # 114H-638-554 Includes:  
113H-0 Size 0 Diaphragm - Hypalon  
160-G-107 Valve Assembly - Hypalon  
160-G-108 Valve Assembly - Hypalon  
160-A-1200 3/8" Sealing Washer - Stainless (2)

**Bone Dry Bottom Inlet Viton Pump Spares Kit**  
Order # 114V-638-554 Includes:  
113V-0 Size 0 Diaphragm -Viton  
160-G-107V Valve Assembly - Viton  
160-G-108V Valve Assembly - Viton  
160-A-1200 3/8" Sealing Washer - Stainless (2)

### 4. Maintenance & Trouble Shooting

**PUMPS USED FOR CRITICAL APPLICATIONS SHOULD BE INSPECTED AND TESTED OFTEN,**

For boat applications at least every six months and at annual commissioning and prior to off shore passage.

Visually Inspect Pump Inside and Out for Corrosion and Wear. Lightly Oil Pivot Pins. Pump Some Water.

If the pump does not pump check first for anything blocking the inlet line. If clear then see instructions below :

1. To check status of the pump and inlet plumbing all at once, seal the open end of the inlet plumbing. If you have a vacuum gage, connect it to the open end of the inlet plumbing. Start pumping. If the plumbing is air tight, you should be able to build a vacuum of 9 to 10 inches of mercury. When you stop pumping the vacuum should very slowly bleed off. This procedure requires inlet plumbing of at least 4 ft. in length. If you can not establish or hold vacuum in the system proceed to step 2.
2. Remove all plumbing from the pump.
3. To check the discharge valve assembly and diaphragm put your hand tightly over the pump inlet and pull back on the handle. You should feel a vacuum suction and if the discharge valve assembly and diaphragm are working properly, you should not be able to raise the diaphragm all the way. If you do not feel any suction, do the same thing again and listen for air being sucked in around the diaphragm. If you hear air movement, inspect for loose bolts or worn diaphragm. If you hear no air movement, remove the discharge chamber and inspect the valve assembly and valve seat. Clean or replace the valve and clean or resurface the valve seat as appropriate.
4. To check the inlet valve assembly raise the diaphragm; put your hand over the discharge and push forward on the handle. If the inlet valve is sealing properly, you should feel the pressure against your hand. If you don't, then remove the inlet chamber and inspect the valve assembly and valve seat. Clean or replace the valve and clean or resurface the valve seat as appropriate.
5. When you are sure the pump is working properly and the pump still will not pump liquid, check the inlet plumbing for leaks. Depending on the height above the liquid even one unsealed fitting can prevent liquid from getting to the pump.

### 5. Performance & Specifications ONE GALLON PER CYCLE

- **Static Head:** Suction 15 ft / 4.57m; Discharge 15 ft / 4.57m (2" ID Pipe or Hose)
- **Dry Suction Lift:** 12 ft / 3.65m (2" ID Pipe or Hose)
- **Volume:** 30 GPM / 113.5 LPM at 5 ft Suction Lift and 0 Discharge at 30 Cycles per Min. w/ 2" Hose

Total Volume depends on the Cycle Rate and the Head conditions of the installation. Volume is expressed in GPM (gallons per minute) and LPM (liters per minute). A Cycle is one complete raising and lowering of the diaphragm. Head conditions are determined by the vertical height, length and size of the plumbing and the viscosity of the liquid.

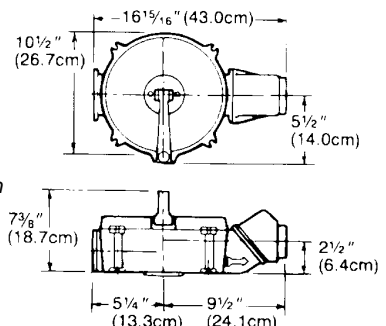

**Edson**  
INTERNATIONAL

146 DUCHAINE BLVD., NEW BEDFORD, MA. 02745-1292 TEL. 508-995-9711 FAX 508-995-5021 E-MAIL pumps@edsonintl.com

### Operation & Parts Manual

638BR-200 Bone Dry Manual, Bottom Inlet, Lever Action, Diaphragm Pump, Bronze, 2" Inlet & Discharge

638BR-150 Bone Dry Manual, Bottom Inlet, Lever Action, Diaphragm Pump, Bronze, 1 1/2" Inlet & Discharge

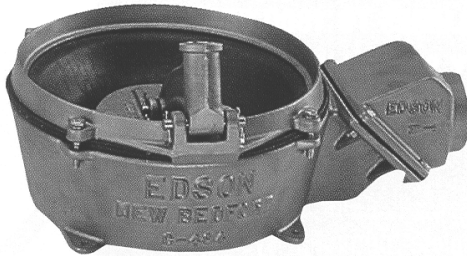

#### Caution

Special Applications - Edson pumps are used for many diverse applications. Some may require special parts or maintenance procedure. i.e.. pumping liquid with gasoline or other fuels requires using Viton diaphragms and valves. If you have any questions regarding procedures for your application, call Edson customer service.

## 1. Installation Guidelines

### Installing the Pump

1. Install the pump in a manner that allows for a comfortable position for pumping and easy access for inspection and maintenance.
2. The head ring and drive arm can be rotated to the four 90 degree positions allowed by the square bolt pattern. (Fig 5 Page 2)
3. The pump is designed to be installed on a relatively horizontal surface using 1/4 " bolts or screws at the four corners of the base (Fig 5). If the mounting surface can not be horizontal, the inlet port should be lower than the discharge.
4. Do not combine incompatible metals i.e.. **no aluminum fittings on a bronze pump or bronze fittings on an aluminum pump.**
5. Check that all nuts and bolts are tight (Fig 5). Requires two 7/16 and one 9/16 box wrenches.

### Installing the Plumbing

1. Fittings and hose couplings must be air tight. Threads must be sealed with pipe sealer.
2. To avoid clogging plumbing on the discharge should be the same size or larger than the inlet.
3. Connect plumbing to the pump using unions or easily removed couplings.
4. For sewage and sump applications using backup check valves on the inlet and discharge will improve the ability of the pump to dry prime.
5. For sewage and sump applications where the discharge drains naturally down and away from the pump installing a positive loop will improve the self priming feature. When you stop pumping the loop traps some liquid against the discharge valve improving the seal. Fig. 1
6. When discharging to a point higher than the pump, install the discharge plumbing so that no air can be trapped in the plumbing. Fig. 2 & 3. Trapped air restricts the flow of liquid and requires more work to pump liquid past the air lock.
7. If the pump is being installed to pump liquids with suspended solids and the use will be intermittent, solid matter can get trapped under the check valves. This will prevent self priming at the next use. Flushing with water will generally clear out the solid matter but installing secondary clear flapper check valves right at the inlet and discharge will improve the dry suction start performance of the pump. Order Edson Clear Check Valves 269CL-200 for 2" or 269CL-150 for 1 1/2"

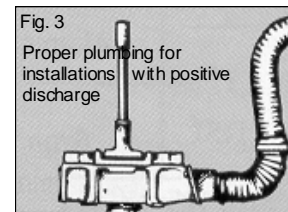
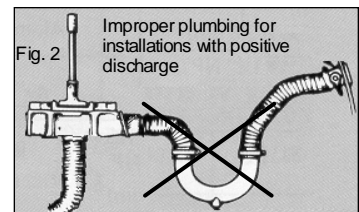
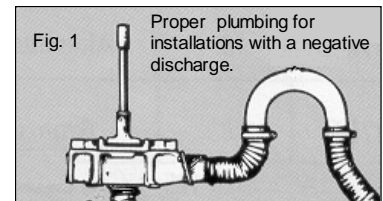
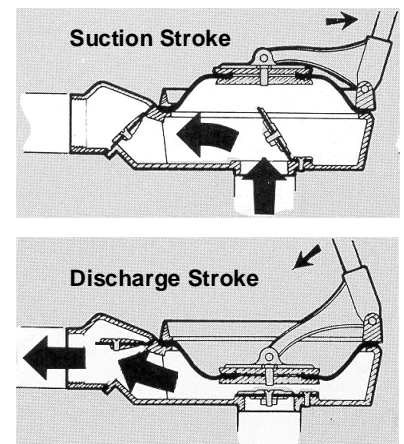

Fig. 4



Inlet Valve Assembly:  
opens into the pump  
Discharge Valve Assembly:  
closes and seals on the valve seat  
that is part of the pump base under  
the discharge chamber.

Discharge Valve Assembly:  
opens away from the pump  
Inlet Valve Assembly:  
closes and seals on the valve seat  
that is part of the inlet chamber.

## 2. Operation

### The Pump Works By:

1. Pulling back on the handle raises the diaphragm creating a vacuum .
2. The vacuum pulls the discharge valve assembly closed.
3. Atmospheric pressure pushes liquid up the inlet plumbing to fill the vacuum.
4. Pushing forward on the handle compresses the air and liquid under the diaphragm closing the inlet check valve and forcing the air and liquid out the discharge.
5. The closing of the inlet valve assembly prevents the liquid and air trapped in the inlet line from dropping back to atmosphere.

### Pump Performance Depends On:

1. An air tight diaphragm.
2. Valve assemblies that seal well on the pump inlet and discharge valve seats.
3. Inlet plumbing that is air tight all the way to the point it is submersed in the liquid.

### 3. Parts List

Fig. 5

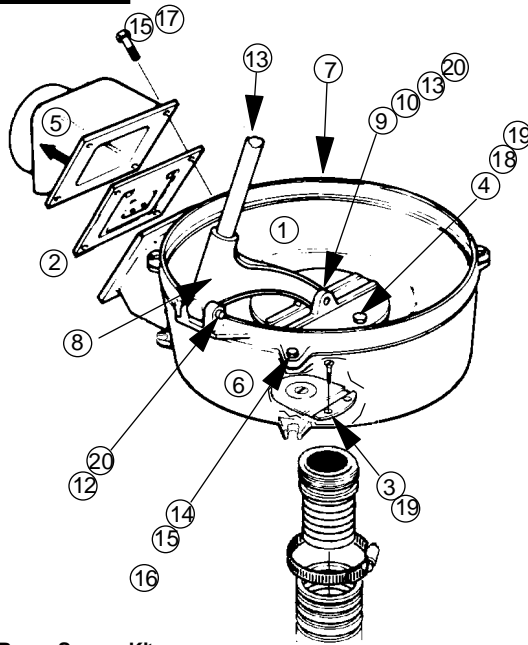

#### 638BR-200 Parts

Key #	Part No.	Description	Qty
1	113H-0	Size 0 Diaphragm - Hypalon	1
2	160-G-107	Bone Dry Pump Valve Assembly - Hypalon	1
3	160-G-108	Bone Dry Pump Valve Assembly - Hypalon	1
4	160-A-1200	3/8" Sealing Washer - Stainless	2
5	160-B-50B-200	2" Discharge Chamber- Bronze	1
6	160-C-494	Bottom Inlet Pump Base - Bronze	1
7	160-C-4B	Headring Bronze	1
8	160-B-28B	Drive Arm -Bronze	1
9	160-A-1B	Upper Standard - Bronze	1
10	160-A-906	Lower Standard -Stainless	1
11	160-A-41	32" Pump Handle with Grip	1
12	160-A-53	Head Ring Pivot Pin	1
13	160-A-54	Standard Pivot Pin	1
14		1/4-20 X 1.5 HHCS Stainless	4
15		1/4-20 Nut Stainless	12
16		1/4" Lock Washer	4
17		1/4-20 X 1" HHCS Stainless	10
18		3/8" Lock Washer	2
19		3/8-16X1" HHCS Stainless	2
20		1/8" X 3/4" Cotter Pin Stainless	4

#### 638BR-150 Parts are the same as above except for the following:

Key #	Part No.	Description	Qty
5	160-B-50B-150	1 1/2" Discharge Chamber - Bronze	1
21	160-A-97	1 1/2" x 2" Reducer Bushing PVC	1

#### Bone Dry Pump Spares Kits

Size 0  
10.5"

113H-0  
A-1200

**Bone Dry Bottom Inlet Hypalon Pump Spares Kit**  
Order # 114H-638-554 Includes:  
113H-0 Size 0 Diaphragm - Hypalon  
160-G-107 Valve Assembly - Hypalon  
160-G-108 Valve Assembly - Hypalon  
160-A-1200 3/8" Sealing Washer - Stainless (2)

**Bone Dry Bottom Inlet Viton Pump Spares Kit**  
Order # 114V-638-554 Includes:  
113V-0 Size 0 Diaphragm -Viton  
160-G-107V Valve Assembly - Viton  
160-G-108V Valve Assembly - Viton  
160-A-1200 3/8" Sealing Washer - Stainless (2)

#### Optional Parts substituted upon request:

Key #	Part No.	Description
1	113V-0	Size 0 Diaphragm -Viton
2	160-G-107V	Bone Dry Pump Valve Assembly - Viton
3	160-G-108V	Bone Dry Pump Valve Assembly - Viton
13	160-A-41ST	32" Pump Handle Stainless 304 with Grip

### 4. Maintenance & Trouble Shooting

**PUMPS USED FOR CRITICAL APPLICATIONS SHOULD BE INSPECTED AND TESTED OFTEN,**

For boat applications at least every six months and at annual commissioning and prior to off shore passage. Visually Inspect Pump Inside and Out for Corrosion and Wear. Lightly Oil Pivot Pins. Pump Some Water. If the pump does not pump check first for anything blocking the inlet line. If clear then see instructions below :

1. To check status of the pump and inlet plumbing all at once, seal the open end of the inlet plumbing. If you have a vacuum gage, connect it to the open end of the inlet plumbing. Start pumping. If the plumbing is air tight, you should be able to build a vacuum of 9 to 10 inches of mercury. When you stop pumping the vacuum should very slowly bleed off. This procedure requires inlet plumbing of at least 4 ft. in length. If you can not establish or hold vacuum in the system proceed to step 2.
2. Remove all plumbing from the pump.
3. To check the discharge valve assembly and diaphragm put your hand tightly over the pump inlet and pull back on the handle. You should feel a vacuum suction and if the discharge valve assembly and diaphragm are working properly, you should not be able to raise the diaphragm all the way. If you do not feel any suction, do the same thing again and listen for air being sucked in around the diaphragm. If you hear air movement, inspect for loose bolts or worn diaphragm. If you hear no air movement, remove the discharge chamber and inspect the valve assembly and valve seat. Clean or replace the valve and clean or resurface the valve seat as appropriate.
4. To check the inlet valve assembly raise the diaphragm; put your hand over the discharge and push forward on the handle. If the inlet valve is sealing properly, you should feel the pressure against your hand. If you don't, then remove the inlet chamber and inspect the valve assembly and valve seat. Clean or replace the valve and clean or resurface the valve seat as appropriate.
5. When you are sure the pump is working properly and the pump still will not pump liquid, check the inlet plumbing for leaks. Depending on the height above the liquid even one unsealed fitting can prevent liquid from getting to the pump.

### 5. Performance & Specifications

**ONE GALLON PER CYCLE**

- **Static Head:** Suction 15 ft / 4.57m; Discharge 15 ft / 4.57m (2" ID Pipe or Hose)
- **Dry Suction Lift:** 12 ft / 3.65m (2" ID Pipe or Hose)
- **Volume:** 30 GPM / 113.5 LPM at 5 ft Suction Lift and 0 Discharge at 30 Cycles per Min. w/ 2" Hose

Total Volume depends on the Cycle Rate and the Head conditions of the installation. Volume is expressed in GPM (gallons per minute) and LPM (liters per minute). A Cycle is one complete raising and lowering of the diaphragm. Head conditions are determined by the vertical height, length and size of the plumbing and the viscosity of the liquid.

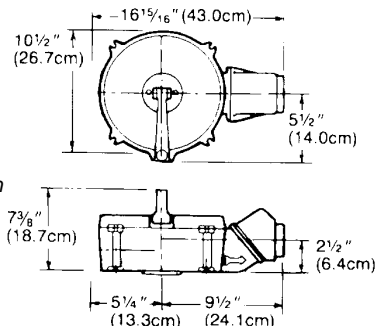

**Edson**

INTERNATIONAL

146 DUCHAINE BLVD., NEW BEDFORD, MA. 02745-1292 TEL. 508-995-9711 FAX 508-995-5021 E-MAIL pumps@edsonintl.com