



1HP VACUUM PUMP OUT SYSTEM WITH INTERGRAL TANK

Installation and Operations Manual

Index

- Page 1 Description
- Page 2 Components & Dimensions
- Page 3 Installation:Guidelines
- Page 3 Installation:Pump Unit
- Page 5 Installation:Plumbing
- Page 7 Installation:Electrical
- Page 14 Installation: Pump Out Hose
- Page 15 Operation
- Page 17 Part
- Page 19 Maintenance

The Pump Unit & Pump Out Components

290 35 1HP - Specifies that this Edson vacuum unit was built with a 35 gallon, stainless steel transfer tank and Model 03, rotary vane, vacuum pump driven by a 1 hp electric motor with an automatic reversing control system. This vacuum unit will develop 23" hg of vacuum (25 ft of suction lift) and 10 psi (23 ft of discharge head) and automatically cycle from suction to discharge when the tank is full.

Pump Out Components - May include but are not limited to a Hose Stand 260-284, a Pump Out Hose Assembly 261-25-150 and a Bronze Hydrant 270BR-150.

ATTENTION
 Fill Oil Reservoir Before Starting VacuMaster.
 See Page 3 for Information



ENTER YOUR VACUUM PUMP DATA HERE

SYSTEM SERIAL #
 From Edson Serial # Sticker On Vacuum Pump Mounting Frame

VACUUM PUMP

Motor
 From Plates On Motor and Reducer.



Components Description & Dimensions

Pump Unit: 290 35 2210. fig. 1

- 1hp/1ph/110v/60hz/tefc Motor
- Model 03 Air Pump
- Automatic Continuous Pumping Control Package
- Nema 4X Control Panel with Key Switch
- 35 Gallon Stainless Steel Tank with Cover

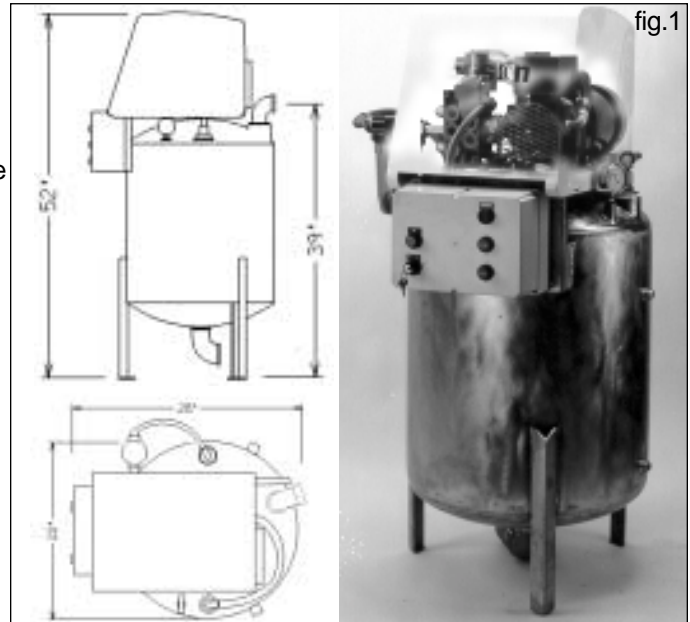

Hose Stand: White Powder Coated Aluminum with Start/Stop Buttons Installed, Operating Instruction Sign and (4) 1/2" X 7" Aluminum Hex Head Mounting Bolts. fig. 2

Hose Assembly: 25' X 1 1/2" Polyflex Hose, 90° Ball Valve, Sight Glass/Check Valve, Quick Clamp Adapter, fig. 2. Complete Set of Waste Deck Fitting Adapters fig. 3

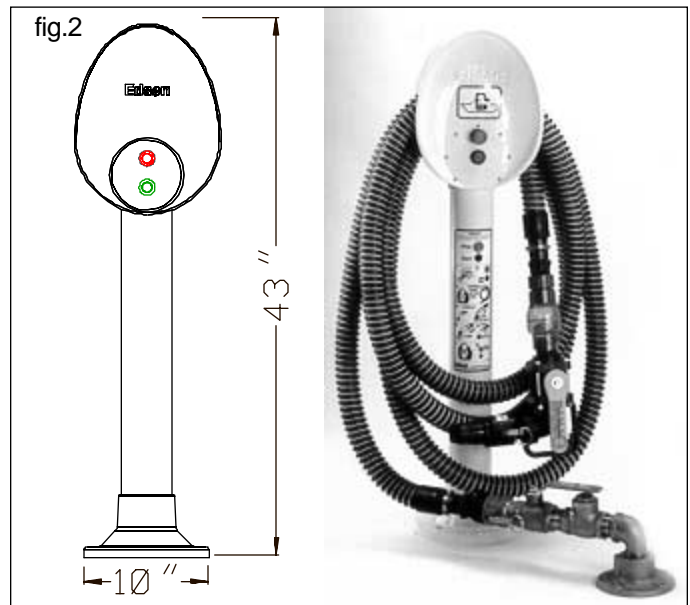
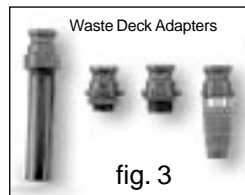

Hydrant: (Optional) 1 1/2" Bronze Check Valve, Ball Valve and Quick Clamp Hose Adapter with Bronze Elbow and Close Nipple with Mounting Flange. fig. 4

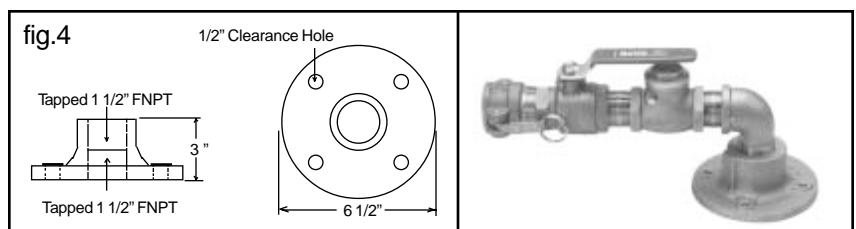

WARNING

It is the responsibility of the purchaser to have the electrical service installed by a licenced electrician in accordance with the power requirements of the motor, the electrical service available and local electrical codes.

Failure to have the electricity installed correctly will result in damage to the pump and potential bodily injury, loss of life and property damage from electrical shock and fire.

CAUTION

Use Recommended Biodegradable Hydraulic Oil or Quality High Detergent 10W-30 or 10W-40 Motor Oil Only

Using the wrong oil or dirty oil can cause loss of vacuum or pump failure.

CAUTION

Bolt Pump Securely To Level Surface

ATTENTION

All Plumbing Fittings Must Be Air Tight. Installed With Thread Sealant.

The Pump Unit:

1. Inspect and Setup the Pump Unit

- Fill Oil Reservoir with A Biodegradable Hydraulic Oil (Mobil EAL 224H) or Any High Detergent 10W-30/40 Motor Oil
- Install Factory Supplied Plumbing To Tank. fig. 4

fig.4

Suction Inlet

All 1½" NPT Fitting

- 90° Street Elbow
 - Close Nipple
- Full Port Ball Valve
 - Close Nipple
- PVC Clear Check Valve with **valve opening to the tank.**

Vacuum Exhaust Control Fittings - See Page 6 before installing.



Oil Reservoir

1 QT. Capacity

- Oiling Tube
- Level Sight Tube



Discharge Outlet

All 2" NPT Fitting

- 90° Street Elbow
 - Close Nipple
- Full Port Ball Valve
 - Close Nipple
- PVC Clear Check Valve with **valve opening away from tank and hinge up.**
- 2" X ½" Tee

2. Locate and Orient the Pump Unit:

- Position Pump Unit between the pump out hose stand and the sewage disposal location.
- Install the pump unit in accordance with the performance specification. fig 5
- Plan Plumbing - Suction plumbing between hose stand and suction inlet of pump unit should be 1½". Discharge plumbing between pump unit and sewage disposal sight should be 2".fig 4 page 3

IMPORTANT

Plan for Vacuum Exhaust Plumbing

- Plan Vacuum Exhaust Plumbing fig 6 - When using a vacuum air pump to pump sewage the vacuum exhaust is very unpleasant. In order to direct the vacuum exhaust into the sewer line the pump unit is equipped at the factory with fittings that will direct the vacuum exhaust air into the discharge line. See page 6 for details. **For negative** head installations the ½" exhaust air line and ½" check valve are connected to the 2" X ½" tee right at the tank discharge just after the 2" check valve. fig 7 **For positive** head installations the exhaust air line must be extended parallel to the discharge line and is connected to the ½" check valve and the 2" X ½" tee at a point where the discharge line will gravity drain.fig 8
 - Plan for Electricity - Electrical cable between hose stand start/stop station and the control panel on the pump unit should be 3 wire + ground rated in accordance with the installation environment and 24 volt power. Electrical cable between the pump unit and main power source should be 2 wire + ground rated in accordance with code for the installation environment and the operation of a 1/2hp 110V 60 hz motor rated at 6.5 Full Loaded Amps.
 - Install for Maintenance - Install the pump in a manner that allows easy access for inspection & maintenance. Connect plumbing to the pump using unions or easily removed couplings.
 - Install the Pump On a Smooth & Level Surface -In order to prevent unnecessary vibration and frame distortion, the pump unit must be installed on a relatively smooth and level surface.
- ## 3. Bolt Pump Frame To Surface:
- Pump frame has 3 bolt down flanges. Use these to secure the unit to the surface with lag bolts or similar fasteners. fig 9

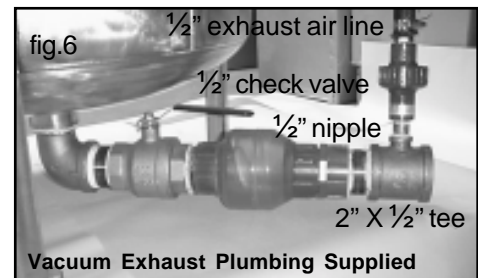
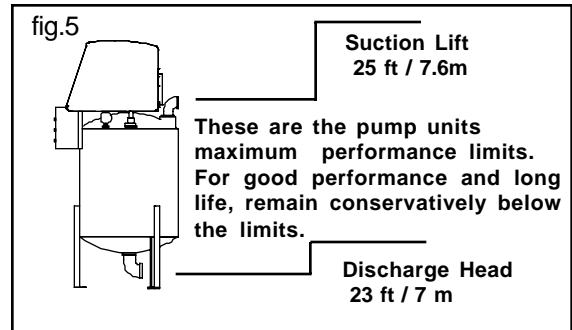

fig. 7 Negative Head Vacuum Exhaust

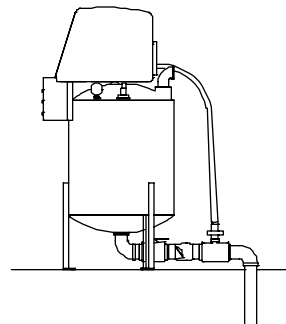

fig. 8 Positive Head Vacuum Exhaust

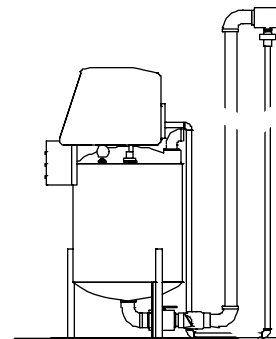

fig.9



The Hose Stand & Hydrant:

P-290-35-1HP-00 pg. 5

1. Inspect the Hose Stand

- Check the hose stand and 4 mounting bolts. Make sure stop/start switches are installed and are secure. fig.10

2. Assemble The Hydrant per fig 11 (Optional)

- Use thread sealant on all components to insure all fittings are air tight.

IMPORTANT

Plan for Electrical Cable for Start/Stop

3. Arrange the Stand and Hydrant at Pump Out Location:

- Position the hose stand and the hydrant so the hose can be easily wound and unwound from the stand. fig 11
- Position the hose stand and hydrant so that the 25 ft. hose can easily reach the boats to be pumped.
- Support hydrant with a plumbing hanger if necessary.
- Use the aluminum mounting bolts to secure the hose stand to the surface. If the 7" mounting bolts supplied can not be used, use appropriate substitutes. Aluminum is recommended.
- Secure hydrant to surface with appropriate hardware.

Install the Plumbing:

1. Install in Accordance with Local Codes & Standard Plumbing Practices

2. Use 1 1/2" ID Hose and/or Pipe on The Inlet and 2" ID On the Discharge fig. 12, 13, 14

- Make all connections air tight. Use pipe sealant.
- Use long radius sewer sweep fittings for all elbows.
- Install clean outs at appropriate locations.
- Use unions when connecting to the pump unit.

3. Prevent Vapor locks

- Prevent vapor locks. If possible install plumbing so air travel up and out and is not trapped in pipes or fittings.

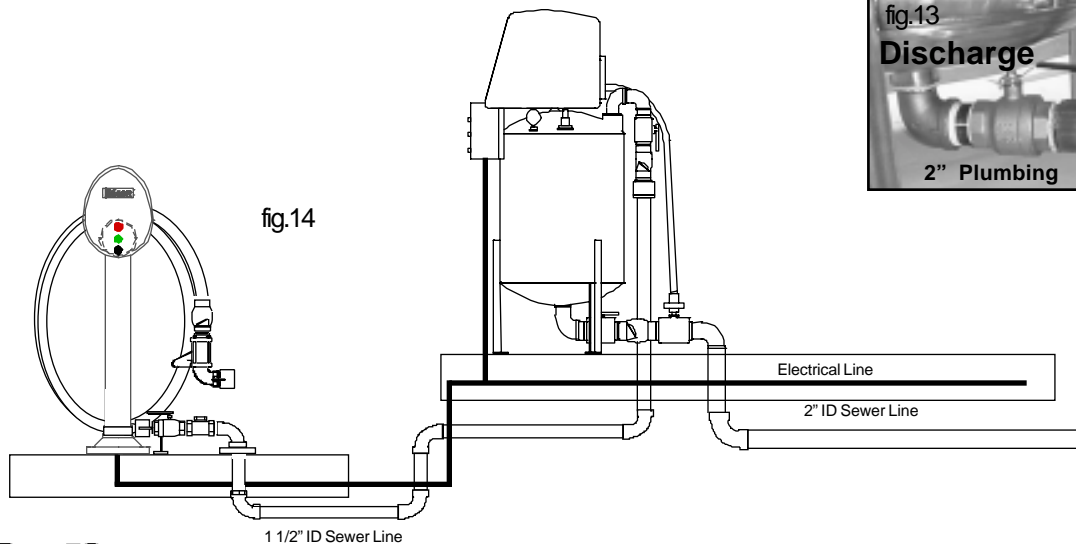
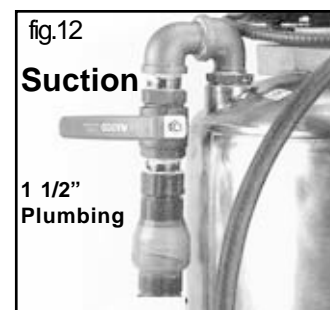
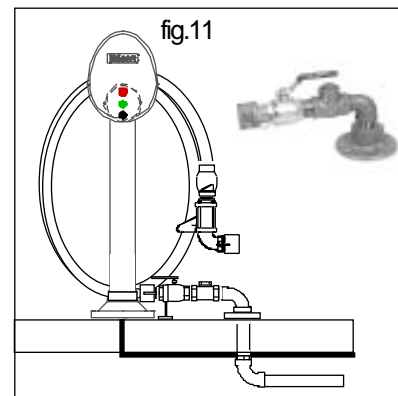
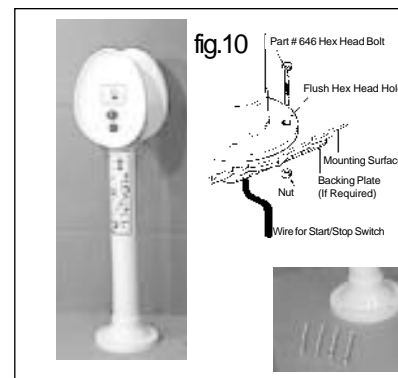

Install the Plumbing: Continued

IMPORTANT
In Some Applications Such As Pumping Sewage Vacuum Exhaust Is Very Unpleasant. Vacuum Exhaust Plumbing Can Be Used To Direct The Unpleasant Exhaust Air Into The Discharge Line Or To An Area Where Unpleasant Odors Do Not Effect Anyone.

4. Install Vacuum Exhaust Plumbing

- Make all connections air tight. Use pipe sealant.
- Use 1/2" Pipe or Hose for exhaust line.
- Use factory supplied 2" X 1/2" tee in tank discharge line to connect exhaust to sewage line.
- Use factory supplied 1/2" check valve to prevent back flow into air exhaust line when pump unit is in discharge mode.
- **For negative** head installations the 1/2" exhaust air line is plumbed from the vacuum exhaust port on the four way valve to the 1/2" check valve on the 2" X 1/2" tee right at the tank discharge just after the 2" check valve. All plumbing supplied by factory. fig 15
- **For positive** head installations: fig 16
 - a. Install the 1/2" check valve and the 2" X 1/2" tee at the point in the 2" discharge line where the discharge line is no longer under positive back pressure.
 - b. Remove the short section of factory installed 1/2" hose from the vacuum exhaust port of the 4way valve located under the cover.
 - c. Connect this port to the 1/2" check valve using 1/2" hose or pipe.

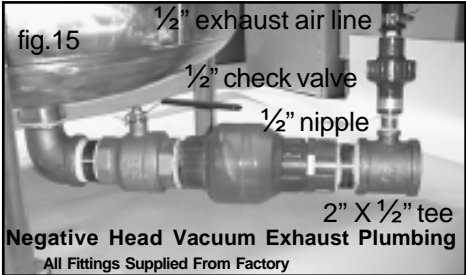

An alternative is to pipe the vacuum exhaust to a location where the odor does not bother anyone.

fig 16 **Positive Head Vacuum Exhaust Plumbing**

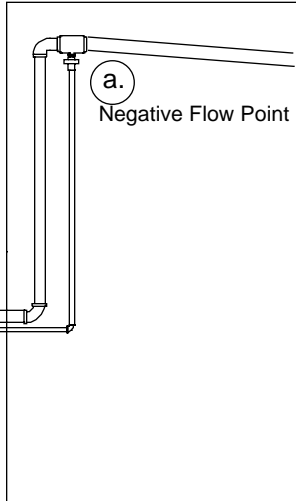
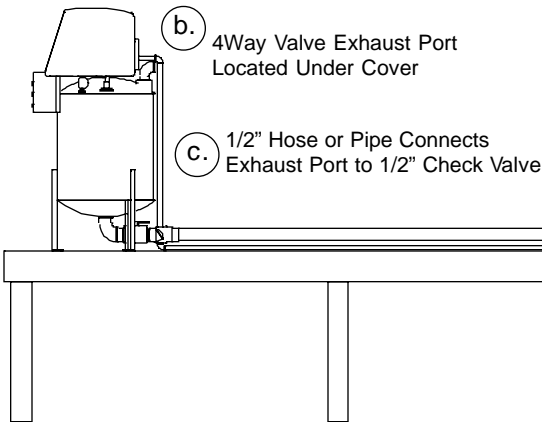

CAUTION
All Electrical Connections Must Be Installed By a License Electrician In Accordance With Local Codes

IMPORTANT
1 HP Motor Operating On 120 Volt Is Rated At Full Load AMPS of 13.4

- 1. Wire The Pump Out Station:** See pages 8,9 & 10
 - Wire Single Phase, 120Volt, 60 HZ electrical power to L1 & L2 on terminal strip inside control panel enclosure. See wiring diagram page 8
 - Insure all components, main control panel and any remote start/stop stations are properly grounded.
 - Insure all connections to the enclosure are water tight.
- 2. Check and/or Set Timers:**
 - TM1 Motor Timer acts as a self-monitoring Shut-Off for the motor. It prevents excessive amounts of water from being pumped into a sewer system because of an inattentive customers or operators. It is factory set to shut the motor off after 10 minutes. fig 17
 - TM2 4way Valve Timer sets the time the 4way valve is in the pressure mode after it automatically switches from vacuum because the transfer tank is full. It is factory set for 1 minute before the system will automatically switch back to vacuum. fig 18
- 3. Install Remote Start/Stop Station(s):**
 - Single Remote Station fig. 21
 - Multiple Remote Stations fig. 22

fig.17 TM1 Motor Timer

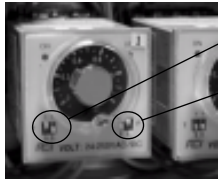

Timer Settings
 T Switches 1 & 0
 F Switches 0 & 1

Turn Timer Dial Full Clockwise for 10 Minutes Run Time

See Page 16 For Manufacturers Data Sheet

fig.18 TM2 4 Way Valve Timer

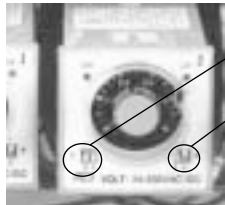

Timer Settings
 T Switches 0 & 0
 F Switches 0 & 1

Turn Timer Dial To Setting That Allows Enough Time to Empty The Tank.

See Page 16 For Manufacturers Data Sheet

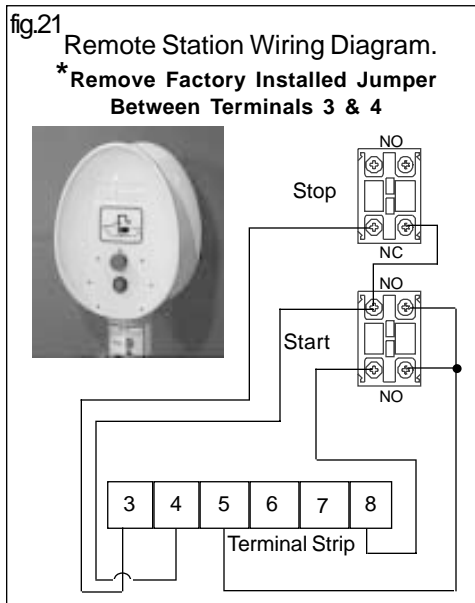

Note: 4 wires are being used to wire the remote stations to the main panel terminal strip.

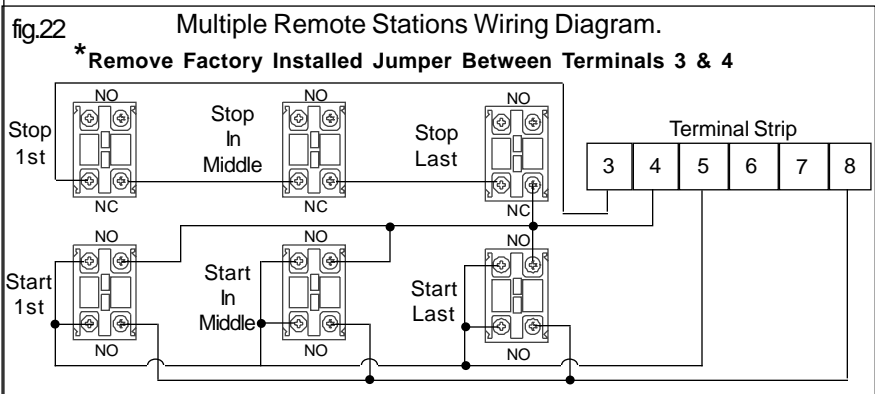

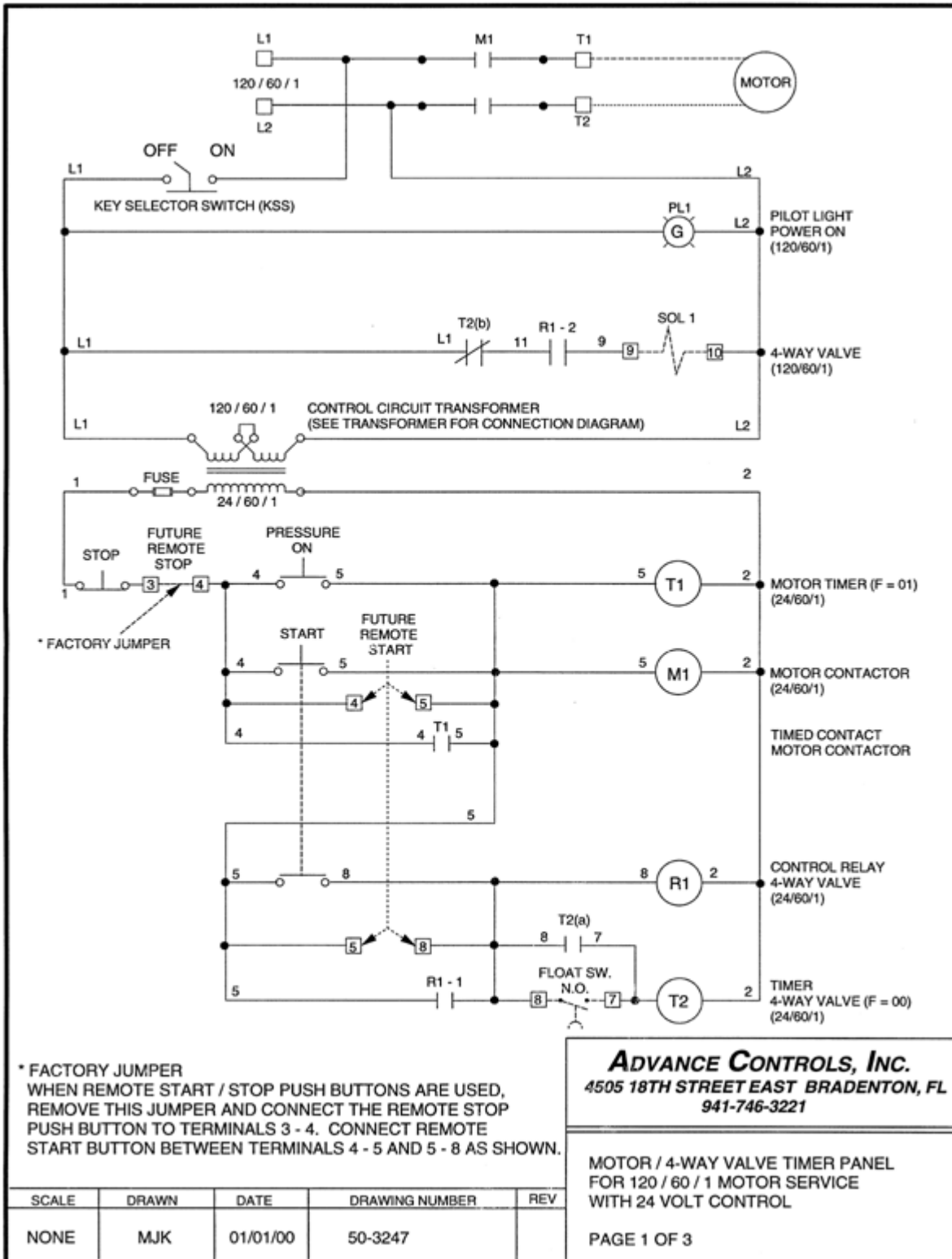

GENERAL LAYOUT OF ENCLOSURE BACK PLATE

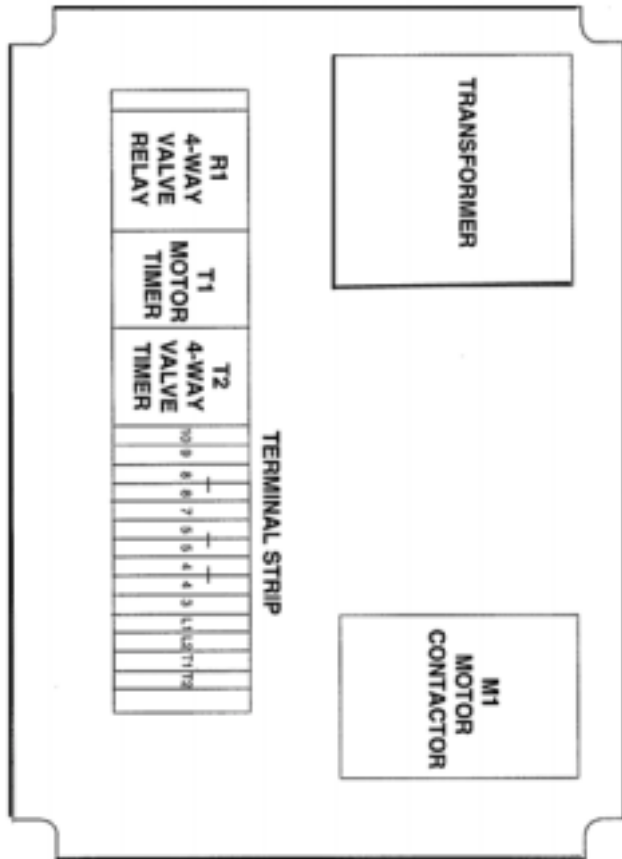

PAGE 2 OF 3		ADVANCE CONTROLS, Inc. 4505 18TH STREET EAST BRADENTON, FL 941-746-3221	
SCALE	DRAWN	DATE	DRAWING NUMBER
NONE	MJK	01/01/00	50-3247
			REV
			MOTOR / 4-WAY VALVE TIMER PANEL FOR 120 / 60 / 1 MOTOR SERVICE WITH 24 VOLT CONTROL

GENERAL LAYOUT OF ENCLOSURE COVER

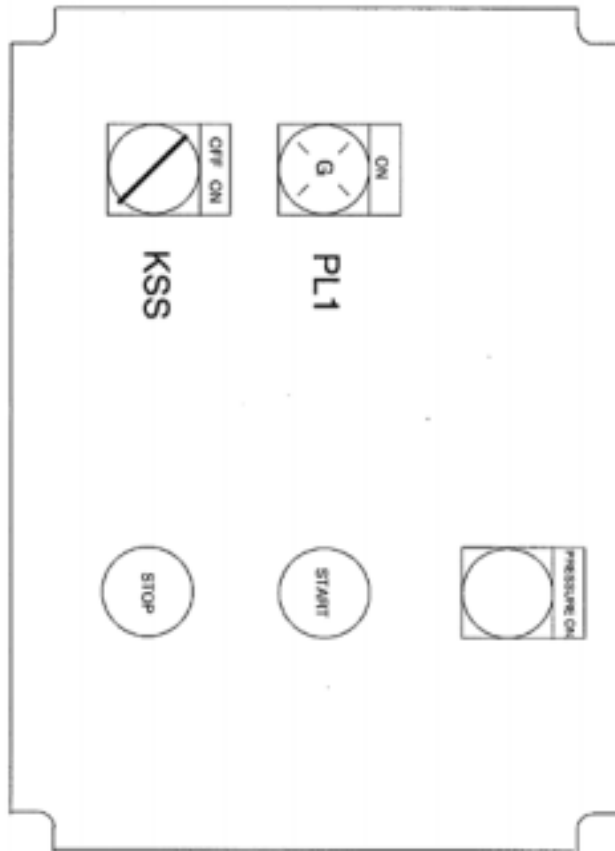

PAGE 3 OF 3

SCALE	DRAWN	DATE	DRAWING NUMBER	REV
NONE	MJK	01/01/00	50-3247	

ADVANCE CONTROLS, Inc.
 4505 18TH STREET EAST BRADENTON, FL
 941-746-3221
 MOTOR / 4-WAY VALVE TIMER PANEL
 FOR 120 / 60 / 1 MOTOR SERVICE
 WITH 24 VOLT CONTROL

85 SERIES TIMER • MULTI FUNCTION/RANGE/VOLTAGE

ADVANCE CONTROLS' 85 SERIES MULTI FUNCTION/RANGE VOLTAGE TIMERS OFFER A CHOICE OF FOUR (4) TIMING FUNCTIONS, FOUR (4) TIMING RANGES, AND A WIDE RANGE OF INPUT VOLTAGES



MULTI FUNCTION: WITH THE PROPER SETTING OF THE "F" (FUNCTION) DIP SWITCH, THIS ACI TIMER CAN FUNCTION EITHER AS AN ON DELAY, REPEAT CYCLE, INTERVAL (REVERSE ON DELAY) OR A REVERSE REPEAT CYCLE TIMER.

MULTI RANGE: WITH THE PROPER SETTING OF THE "T" (TIME) DIP SWITCH, THE ACI TIMER OFFERS A CHOICE OF FOUR (4) TIMING RANGES (0.05 / 1 SEC : 0.12/10 SEC: 0.6 SEC/1 MIN: 6 SEC/10 MIN. OR 0.05/1 MIN: 0.12/10 MIN: 0.6 MIN/1 HOUR: 1 MIN/10 HOUR).

WIDE RANGE INPUT VOLTAGE: A WIDE RANGE OF INPUT VOLTAGES ARE ALLOWED (24 VAC/VDC THROUGH 240 VAC/VDC, 50/60 HZ) WITHOUT WIRING CHANGES OR DIP SWITCH SETTINGS.



THE FEATURES OF THE ADVANCE CONTROLS TIMER MINIMIZE INVENTORY WHILE MAXIMIZING THE BENEFITS FOR TIMER APPLICATIONS.

CATALOG NUMBERS / TIME RANGES

CATALOG NUMBER	MODEL NUMBER	OUTPUT	TIMING RANGE	DIP SWITCH "T" (TIME RANGE) SETTING				LIST PRICE
				0 0	1 0	0 1	1 1	
104214	8511A240	11 PIN	SEC [s] - MIN [m]	0.05s - 1s	0.12s -10s	0.6s-1m	6s-10m	\$ 64.00
104216	8521A240	DPDT	MIN [m] - HOUR [h]	0.05m - 1m	0.12m-10m	0.6m-1h	1m-10h	64.00
104217	8542A240	8 PIN	SEC [s] - MIN [m]	0.05s - 1s	0.12s-10s	0.6s-1m	6s-10m	62.00
104218	8552A240	SPDT	MIN [m] - HOUR [h]	0.05m - 1m	0.12m-10m	0.6m-1h	1m-10h	62.00

FUNCTION CHART

FUNCTION	DIP SWITCH "F" (FUNCTION) SETTING	DESCRIPTION
"ON" DELAY	0 0	TIMING BEGINS WHEN POWER IS APPLIED TO THE UNIT. THE OUTPUT CONTACTS TRANSFER WHEN THE TIME DELAY SETTING IS REACHED TO RESET THE TIMER. REMOVE THE INPUT POWER OR OPERATE THE CUSTOMER SUPPLIED EXTERNAL "RESET" SWITCH.
REPEAT CYCLE	1 0	TIMING BEGINS WHEN POWER IS APPLIED TO THE UNIT. THE OUTPUT CONTACTS TRANSFER WHEN THE TIME DELAY SETTING IS REACHED. THE OUTPUT CONTACTS REMAIN TRANSFERRED UNTIL THE TIME DELAY SETTING IS AGAIN REACHED. THE OUTPUT CONTACTS ARE THEN RELEASED AND RETURN TO THE ORIGINAL STATE. THE TIMER THEN AUTOMATICALLY RESETS AND REPEATS THE TIMING CYCLE UNTIL THE INPUT POWER IS REMOVED.
INTERVAL (REVERSE ON DELAY)	0 1	APPLYING POWER TO THE TIMER IMMEDIATELY TRANSFERS THE OUTPUT CONTACTS AND TIMING BEGINS. ONCE THE TIME DELAY SETTING IS REACHED, THE OUTPUT CONTACTS ARE RELEASED. THE TIMER IS RESET EITHER BY REMOVING THE INPUT POWER OR OPERATING THE CUSTOMER SUPPLIED EXTERNAL "RESET" SWITCH.
REVERSE REPEAT CYCLE	1 1	APPLYING POWER TO THE TIMER IMMEDIATELY TRANSFERS THE OUTPUT CONTACTS AND TIMING BEGINS. THE OUTPUT CONTACTS REMAIN TRANSFERRED UNTIL THE TIME DELAY SETTING IS REACHED. THE OUTPUT CONTACTS ARE THEN RELEASED AND WHEN THE DELAY SETTING IS AGAIN REACHED, THE OUTPUT CONTACTS TRANSFER AND REMAIN TRANSFERRED UNTIL THE TIME DELAY SETTING IS AGAIN REACHED. THE TIMER CONTINUES TO AUTOMATICALLY REPEAT THE CYCLE UNTIL THE POWER IS REMOVED.

RESET SWITCH: RESETS THE TIMER TO ZERO. REQUIRES CUSTOMER SUPPLIED MOMENTARY SWITCH.

MEMORY SWITCH: PAUSES THE TIMING CYCLE AT THAT POINT IN THE CYCLE. WHEN RELEASED, IT ALLOWS THE CYCLE TO RESUME FROM THE SAME POINT. REQUIRES A CUSTOMER SUPPLIED MOMENTARY SWITCH.

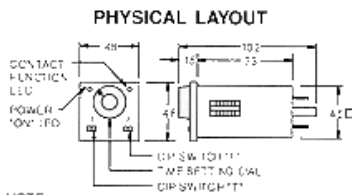

- NOTE:
- 1) SQUARE PANEL MOUNT ADAPTOR (DIN 48 MM) AVAILABLE FOR SNAP MOUNTING INTO A PANEL CUTOUT
 - 2) ALL DIMENSIONS ARE IN MILLIMETERS (INCHES = MM/25.4)

CONNECTION DIAGRAM

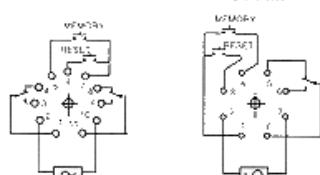

INPUT VOLTAGE: 24 - 240 VAC/VDC 50/60 HZ

SOCKET: ZVR11 OR ZVD11 SOCKET: ZVR8 OR ZVD8

SPECIFICATIONS

INPUT VOLTAGE: 24-240 VAC/VDC 50/60 HZ
 CONTACT RATING: 10A/250 VAC 10A/30 VDC
 MOUNTING: 8 OR 11 PIN OCTAL BASE

INPUTS: POWER,
 MEMORY (OPTIONAL),
 RESET (OPTIONAL)

ELECTRICAL LIFE: 250,000 CYCLES

REPEATABILITY: +/- 1%

SETTING TOLERANCE: +/- 10%

RESET TIME: 0.1 SEC MAX

OPERATING TEMP:

+15 +120 DEG. F (-10 +50 DEG. C)

OPERATING HUMIDITY: 85% RH MAX

Install the Pump Out Hose Assembly

1. Assemble and Install the Pump Out Hose

- **Use Pipe Sealant On All Threads When Assembling Hose Components.**
- Hose Adapter is a female cam lock fitting. Screwed into the Ball Valve to provide a secure air tight connection to a boat waste deck adapter.
- 90° Ball Valve keeps the hose from dripping when connected and disconnected from waste deck fittings.
- Check Valve/Sight Glass allows visual confirmation of flow and also prevents back flushing.
- Pump Out Nozzle is a flexible adapter for use when the threaded waste deck adapters can not be used. It is clamped onto the Hose Adapter on the suction end of the hose and then held into the boat waste deck fitting.
- Deck Adapters are threaded waste deck fitting adapters. They are screwed into a boat waste deck fitting so the Hose Adapter can be clamped in place.
- Potty Wand is a nozzle extension for use when pumping out portable toilets.
- Hydrant Adapter is a fitting used to adapt the thread on the end of the hose to male quick clamp for use with hydrants

fig.23

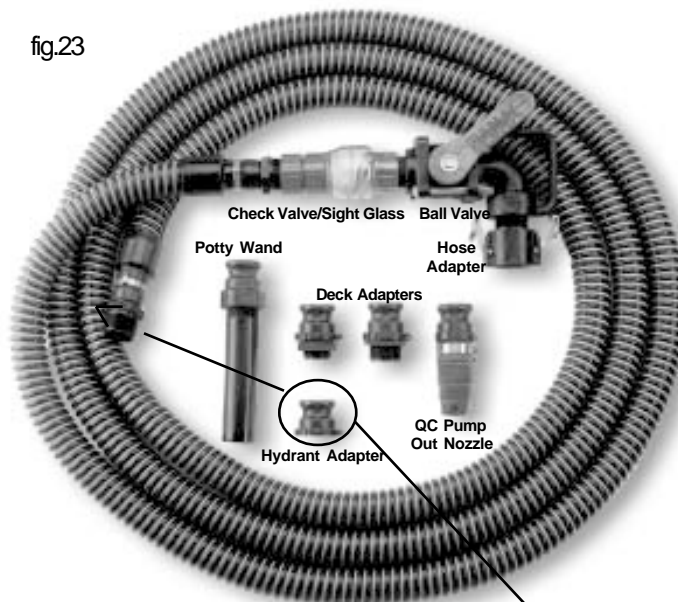

fig.24



IMPORTANT

**All Testing Should Be Carried Out Using Available Clean Water.
Do Not Pump Waste Liquids Until You Are Sure Unit Is Operating Properly**

Pump Unit Test:

1. Turn Key Switch On:

- Green light on front of enclosure comes on.
- Power is on to start/stop and pressure switches on enclosure and start/stop switches on remote stations.

2. Press Any Green Start Switch:

- Motor starts and drives the air pump.
- 4way valve is turned on so that vacuum side of the air pump connects to the tank depressurizing the tank.
- A small amount of oil from the reservoir is drawn into the pump lubricating it.
- With the tank check valves in place and the ball valves open vacuum should be felt on the inlet side of the tank but the tank gauge will read zero.
- Close the inlet ball valve and watch the pressure/vacuum gage. The gauge should record vacuum (Hg) pressure. Open the inlet ball valve and the gauge should drop back to zero.
- Press the red stop button to stop the motor and turn off the 4way valve or let the unit run till the TM1 timer times out and the motor turns off automatically.

3. Press Any Red Stop Switch With The Motor Running:

- Motor stops and 4way valve turn off.

4. Press Black Pressure Switch:

- Motor starts and drives the air pump.
- The pressure side of the air pump is connected to the tank pressurizing the tank.
- A small amount of oil from the reservoir is drawn into the pump lubricating it.
- With the tank check valves in place and the ball valves open pressure should be felt on the discharge side of the tank but the tank gauge will read zero.
- Close the discharge ball valve and watch the pressure/vacuum gage. The gauge should record pressure (psi). Open the discharge ball valve and the gauge should drop back to zero.
- Press any red stop button to stop the motor or let the unit run till the TM1 timer times out and the motor turns off automatically.

5. Float Switch Controls The Automatic Switching of The Pump Unit From Vacuum to Pressure:

- Press any green start switch and vacuum clean water into the tank.
- When tank is full float switch will go horizontal. This turns off the 4way valve. The pressure side of the air pump is now connected to the tank and the pressure empties the tank through the discharge line.
- When the TM2 timer times out the 4way valve comes back on and the vacuum side of the air pump starts to depressurize the the tank again.
- This cycle will continue until the TM1 timer times out or any red stop switch is pushed.

6. Necessary For Good Pumping Operation:

- All electrical components operating properly.
- Tank inlet and discharge check valves installed correctly and sealing properly. fig 4 page 3
- Float switch positioned at correct height inside the tank.
- Suction and discharge plumbing air tight.

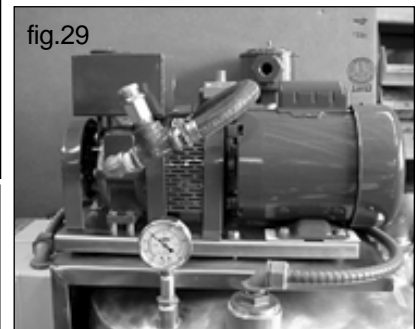
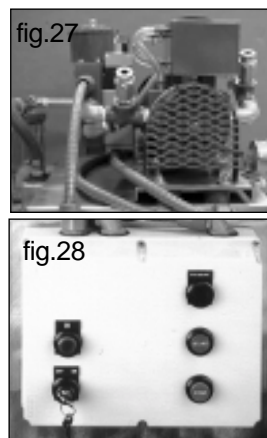
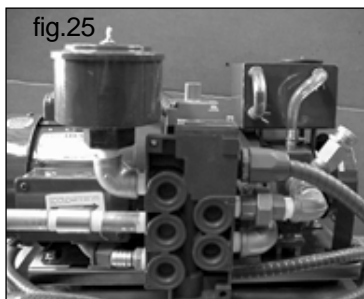

WARNING

Depressurize The System Before Removing Any Parts.
Never Adjust The Pressure Relief Regulator When The System Is On & There Is A Pressure Reading On The Gauge. The Adjusting Nut Could Blow Off And Cause Serious Injury

1. Check regulator settings

- Regulators have been factory set at 15" hg vacuum and 10 psi pressure.
- Close the ball valves at the top and bottom of the tank. Run the VacuMaster in vacuum for 2 to 3 minutes and record the gauge reading. Then run the VacuMaster in the pressure mode for 2 to 3 minutes and record the gauge reading.

Tools:
 Adjustable Crescent Wrench
 Channel Locks

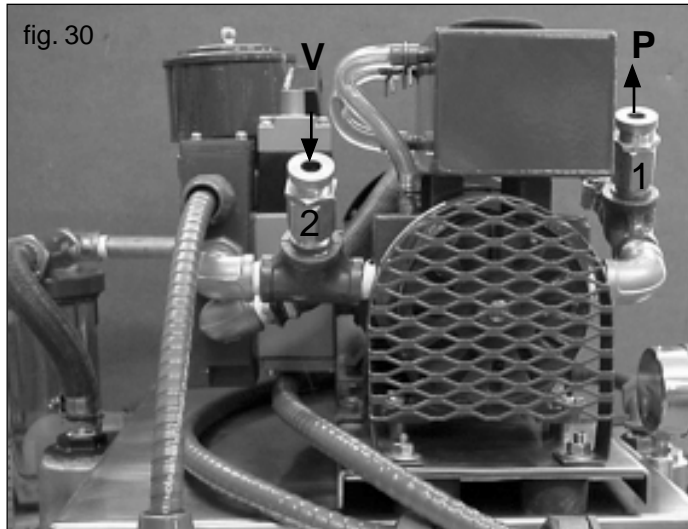

2. Reset regulators per the following instructions:

● **Adjust Pressure Regulator 1**

- Step 1 Close inlet and discharge ball valve.
 - Step 2 Run VacuMaster in the pressure mode. Record pressure reading, turn system off. **Allow Tank To Depressurize. Do Not Adjust Pressure Regulator With System On. Regulator Adjusting Screw Could Blow Loose and Cause Bodily Injury.**
 - Step 3 Loosen locking nut counter clockwise.
 - Step 4 If pressure setting is too low, turn knurled hub clockwise to increase pressure at which valve opens. If pressure is too high, turn hub counter clockwise.
 - Step 5 Tighten locking nut. Turn on system.
- Repeat steps 2-5 until pressure is set.

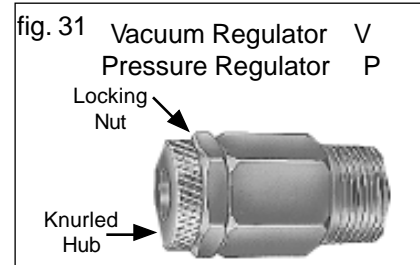

● **Adjust Vacuum Regulator 2**

- Step 1 Close inlet and discharge ball valve.
 - Step 2 Run VacuMaster in the vacuum mode. Record vacuum reading, turn system off. **Allow Tank To Depressurize. Do Not Adjust Pressure Regulator With System On. Regulator Adjusting Screw Could Blow Loose and Cause Bodily Injury.**
 - Step 3 Loosen locking nut counter clockwise.
 - Step 4 If vacuum setting is too low, turn knurled clockwise to increase pressure at which valve opens. If vacuum is too high, turn hub counter clockwise.
 - Step 5 Tighten locking nut. Turn on system.
- Repeat steps 2-5 until vacuum is set.

Pumping Out

1. **Make Sure Hydrant Ball Valve Is Open & Hose 90° Ball Valve is Closed.**
2. **Prepare The Waste Deck Fitting On the Boat.**
 - Remove the cap from the deck fitting.
 - Screw in a deck adapter, 1 1/2" or 1 1/4".
 - If neither fit, clamp the pump out nozzle to the hose.
 - If pumping out a portable holding tank or bucket, clamp the potty wand to the hose.

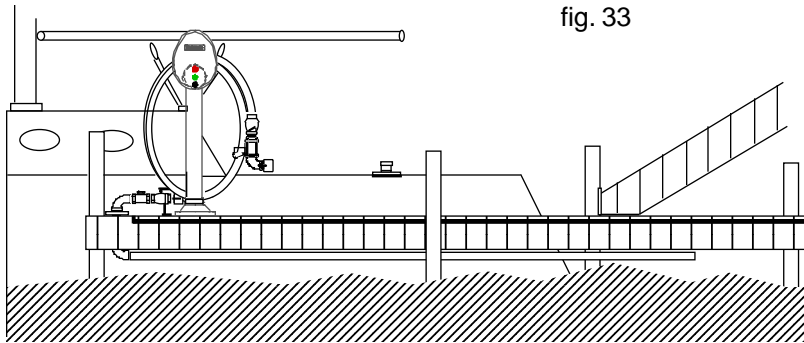

3. **Turn On The Pump Out System.**
 - Push the green start button
4. **Connecting The Hose To The Boat**
 - Unwind the hose all the way from the hose stand.
 - Clamp the hose to the deck adapter or hold the pump out nozzle in the deck fitting.

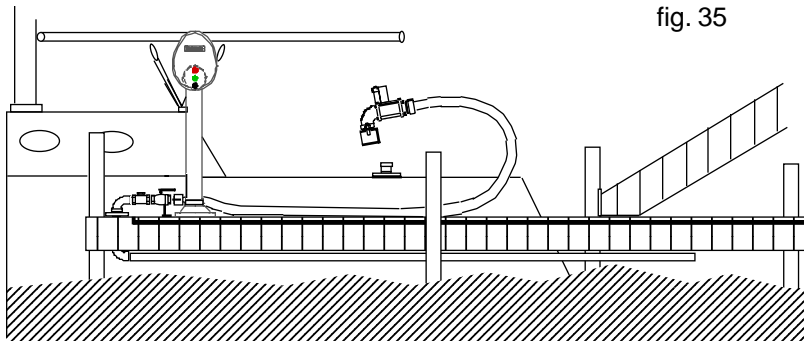

5. **Open The Ball Valve Slowly & Pump Out.**
 - When the holding tank is empty, close the ball valve.
 - Pump water through your toilet into the holding tank.
 - Pump out again. This procedure rinses the entire system and helps to prevent odor.
 - Close The Ball Valve & Disconnect The Hose
6. **Flush the Hose.**
 - Put the hose into water & open the ball valve for 10 sec.
 - Lift the hose and close the ball valve.
 - Push the Red Stop Button.
7. **Clean Up.**
 - Curl the hose onto the hose stand.
 - Secure the boat deck fitting.
 - Rinse the deck and pump out with water.
 - Wash your hands.

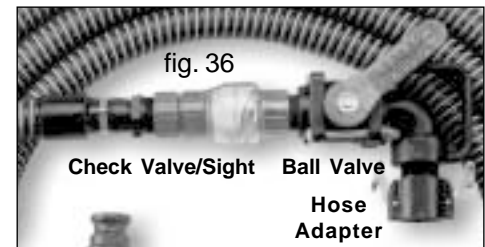
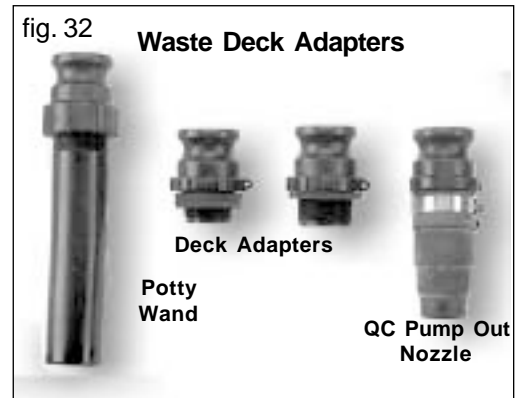

Parts

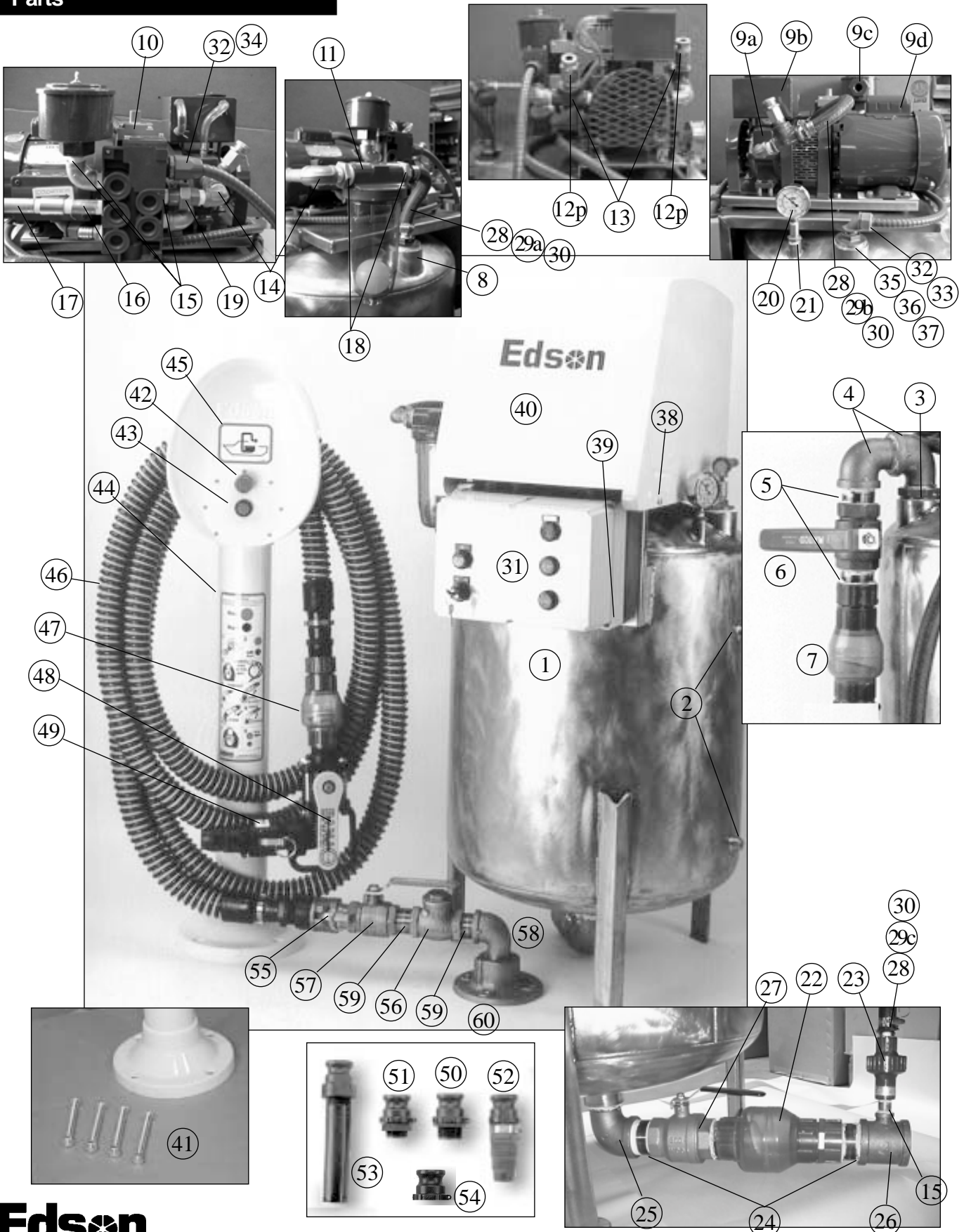

Parts List

No.	Qty.	Edson Part #	Description
1	1	A-1976	Tank, Stainless Steel 45(35 Effective) Gal
2	2	A-2081SS	Plug with Socket 1/2 " SS
3	1	A-939-BR	Bushing, Reducer 2" X 1 1/2"
4	2	A-1711-150	Elbow, 90 Street 1 1/2"
5	2	A-1708-150	Nipple, 1 1/2" Close Brass
6	1	A-1709-150	Valve, Ball 1 1/2" Full Port Bronze
7	1	269CL-150	Check Valve/Sight Glass, Clear 1 1/2"
8	1	A-2131	Trap, Primary w/ 2" X 1/2 Reducer Bushing(<i>Trap Inside Tank, Not Shown</i>)
9	1	A-2071 a,b,c,d	a-Vacuum Pump #3, b-Oil Reservoir, c-Air Filter, d-1 HP Motor
10	1	A-2073	Valve, Electric 1/2" 4 Way
11	1	A-2025	Trap, Poly W/ 1" Ball
12	2	A-2013-P & -V	Valves, Regulator, Pressure (P) & Vacuum Relief (V)
13	2	A-2118	Tee, 3/4" X 3/4" SS
14	8	A-2119	Elbow, 90 Degree 1/2" SS
15	9	A-2120	Nipple, Close 1/2" SS
16	3	A-2121	Nipple, 3" X 1/2" 304SS
17	0	Not Used	Nipple, 6" X 1/2" SS
18	2	A-2123	Bushing, Reducer 1" X 1/2" 304SS
19	0	Not Used	Union, 1/2" Bronze
20	1	A-1824	Gauge, Vac 0-30hg/0-30psi
21	1	A-1824	Bushing, Reducer 1/2" X 1/4" Bronze
22	1	269CL-200	Valve, Clear Check 2"
23	1	A-2125	Valve, Check 1/2 PVC Union
24	2	A-1708-200	Nipple, 2" Close Brass
25	1	A-1711-200	Elbow, 90 Street 2"
26	1	A-2076	Tee, Reducer 2" X 1/2" Bronze
27	1	A-1709-200	Valve, Ball 2" Full Port Bronze
28	6	A-2078	Hose Barb, 1/2" MNPT X 5/8 Brass
29	1	A-2080 a,b,c	Hose 5/8 X 13" Reinforced a-8", b-13", c-46"
30	6	A-599-HS10	Clamp, Hose 9/16" to 1 1/16 SS
31	1	A-2109	Panel, Electrical Advanced Control # 50-3381
32	5ft		Conduit Electrical 3/8 Carlon Carflex
33	4		Fitting, Electrical 90° for 3/8 Carflex CarIT20C
34	2		Fitting, Electrical for 3/8 Carflex CarIT20C
35	1	A-2075	Weight, Float (<i>Inside Tank, Not Shown</i>)
36	1	A-2074	Float Switch MDI- Order # AS2OW0500(<i>Inside Tank, Not Shown</i>)
37	1	A-2055	Bushing, Reducer 2" X 1/2" , Bronze
38	4		1/4-20 x 1" Hex Bolts
39	4		10-32 Machine Screws
40	1	D-190	Cover Fiberglass
Hose Stand 260-284			
41	4	646-7Hex	Hex Head Aluminum Bolts
42	1	161-A-1705	Momentary Mushroom Switch Red
43	1	161-A-1704	Momentary Switch Green
44	1	161-A-1693-2	Pump-Out Instruction Sign
45	1	1610-A-1693-3	Pump-Out Logo Sign
Hose Assembly 261-25-150			
46	25ft	262-25-150	Hose
47	1	269CL-150	Clear Swing Check Valve
48	1	264-90-150	90 Degree Ball Valve 1.5"
49	1	152FM-150NY	Quick Clamp Adapter 1 1/2" FQC X MNPT
50	1	273-150	1 1/2" Deck Adapter
51	1	273-125	1 1/4" Deck Adapter
52	1	272QC-150	QC Pump Out Nozzle
53	1	274-150	Potty Wand
54	1	158MF-150NY	Adapter, Quick Clamp X Female NPT 1 1/2"
Bronze Hydrant 270BR-150			
55	1	152MF-150BR	Adapter, Quick Clamp Female QC X MNPT 1 1/2" Bronze
56	1	269BR-150	Valve, Swing Check Bronze
57	1	264-150BR	Valve, Ball Full Port 1 1/2" Bronze
58	1	160-A-1711	Elbow , 90 Street 1 1/2" Bronze
59	2	160-A-1708-150	Nipple, Close 1 1/2" Brass (Qty 2)
60	1	160-B-468	Flange, Size 0 Bronze Tapped 1 1/2" FNPT Both Ends

Caution

Turn System Off At Main Power Source When Doing Any Maintenance That Requires Undoing Or Opening Parts Of VacuMaster. Failure To Lock Out Power Could Result In Injury.

Maintenance Schedule:

1. Daily When In Use:

- **Flush tank with fresh water.**
- **Check Valves-** Each Edson unit is equipped with two clear 2" check valves. (Some Applications require BRONZE CHECK VALVES). The check valves are designed to operate automatically, opening and closing when the unit switches from vacuum to pressure mode. In the vacuum mode, the check valve mounted near the top to the tank should be open. If the unit is not pumping properly or pumping is taking longer than normal, the intake and outlet check valve should be checked to see if any debris is keeping it from opening completely. If a check valve is clogged, it may be removed for cleaning or you can try the following:
 1. Close the discharge check valve.
 2. Start the pump in the vacuum mode.
 3. Suck clean water into the tank flushing the inlet check valve.
 4. When the tank is full close the inlet ball valve and let pressure build in the tank.
 5. Open the discharge ball valve to flush the discharge check valve.
- **Moisture Traps-** The Edson unit is equipped with a primary ball and cage shutoff which is built into the tank. This primary shutoff will shut off the vacuum line to the pump in the event the level control probe fails. A secondary clear bowl moisture trap is installed on the tank to pump line in case any moisture or waste gets past the primary shutoff. This clear bowl trap should be checked periodically for moisture and drained accordingly.
- Rewind hose.

2. As required:

- Check oil level. Refill when low. Use biodegradable hydraulic oil or 10W-30 or 10W-40 oil.
- Drain and clean secondary trap.
- Do pressure test. Page 13

3. Once a Year:

- **Clean Regulators:** Take each regulator apart and wipe clean. Reassemble and adjust per instructions. Page 14
- **Air Filter-** Replace as required. Order# 161-A-1629-A The air filter is found inside the canister. It is a cartridge filter that removes particles from ambient air when the vacumaster is in the pressure mode.
- **Flush Air Pump -** Flush the system at least once a year (twice a year if used regularly) or if the pump gets a significant amount of water sucked into it.

Air Pump Flushing

Performed for regular maintenance, in cases of water being sucked into the pump (*See Trouble Shooting / Condition 3 pg. 19*) sucked into the pump or vacuum pump does not turn freely by hand.

1. Unscrew Vacuum Regulator.
2. Pour about 1/2 cup of kerosene into the tee opening. It will drain down into the pump.
3. Press the Pressure Button for the count of 5 and then press the Stop Button.
4. Let the pump sit for 10 min. and then run in the pressure mode for about 15 seconds. If pump will not run let the kerosene sit for two hours. Try and turn the pump by hand. If it still will not turn, wait one day. If after one day the pump will not turn over, the pump must be disassembled and cleaned.
5. If the pump runs, make sure the oil reservoir is full and run the pump so oil enters the pump unit.

Air Pump Maintenances & Rebuilding

The main replaceable parts are vanes (four per pump), bearings (two per pump) and seals (two per pump)

See for Conde "Operating Instructions" for detailed instructions on rebuilding the Conde pump. Service kits are available for mechanically inclined owners and operators. We also offers a factory exchange program and a factory repair program.

Condition 1. No Vacuum At The Pump Out Hose

After pressing the green start button and waiting approximately 2 minutes before opening the pump out hose ball valve, there is no indication of a vacuum. Close ball valve on the hose and see Steps below.

Isolating The Problem:**Step 1 - Check motor. Push green start button on pump unit.**

1. Motor is not running. See Electrical & Trace Problem.
2. Motor is running, but there is low or 0 vacuum reading on the pressure gauge. Proceed to Step 2

Step 2 - Check for tank pressure leak. Close inlet and discharge ball valves on the tank.

1. Vacuum gauge still reads 0. See Condition 2.
2. Vacuum gauge builds vacuum to regulator preset. Proceed to Step 3

Step 3 - Isolate pressure leak. Close tank ball valves with unit running in vacuum and open discharge ball valve.

1. Vacuum gauge drops. See Check Valves, Pg. 18.
2. Vacuum gauge holds vacuum to regulator preset. Proceed to Step 4

Step 4 - Isolate pressure leak. Close tank ball valves with unit running in vacuum and open suction ball valve.

1. Vacuum gauge drops. Check for break in suction line. Check Suction Plumbing
2. Vacuum gauge holds vacuum to regulator preset but no vacuum. Check for blockage in suction line

Condition 2. Air pump is running but vacuum/ pressure guage reads 0 or very low with inlet and discharge ball valves closed. Problem is isolated to vacuum pump unit. Remove cover and track pump unit operation in the following sequence: (Keep Ball Valves Closed)

1. Check air pump. Run pump unit in pressure mode and check for vacuum at air filter inlet. If no vacuum at air filter, remove filter cartridge and flush air pump. See pg.18. If ok.....
2. Check for air leaks in air pump assembly plumbing. If found tighten or replace fitting or hose. If ok.....
3. Check regulators. See Pg.14. If ok.....
4. Check 4 way electric valve. Remove exhaust and tank hose from out put side of valve. Run unit in vacuum and pressure mode. Is valve switching positions? Is pressure and vacuum strong. If no, call Edson for replacement. If ok.....
5. Check primary trap - ball may be stuck in valve seat. If ok call Edson Customer Service

Condition 3. The Secondary Trap Is Filled With Water.

This usually means that the float switch or the 4 way electrical valve failed to switch the air pump from vacuum to pressure. The primary trap failed to prevent water from being sucked into the secondary trap and possibly the air pump and 4 way valve.

1. Unscrew and empty secondary trap bowl. Put it back and run pump in pressure mode to clear pump and air line of any water. Empty secondary trap bowl again if necessary.
2. Flush air pump See pg.18
3. Turn pump unit off with key switch. Remaining repairs should be done by a licenced electrician familiar with float switch operation. Contact Edson Customer Service for Instructions

Distances

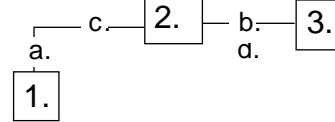

Legend
 Elevation:
 a. 13 ft
 b. 0 ft
 Horizontal:
 c. 500 ft
 d. 100 ft

All dimensions are approximate.
Should **not** be used for Contractor estimating.



2. Edson VacuMaster

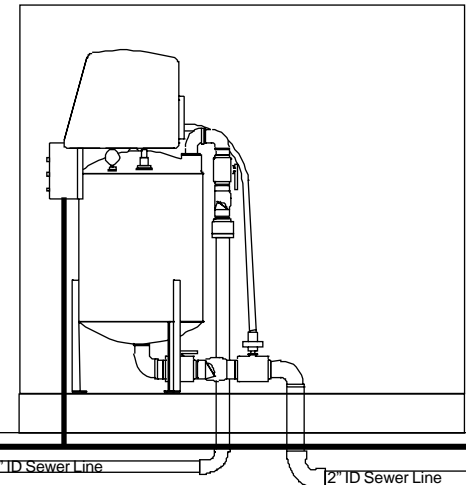

1. Pump Out Hose & Stand with Hydrant

