



3HP VACUUM PUMPING EQUIPMENT WITH PROBES

Maintenance & Troubleshooting Manual
290 - 60 - 22420 and 290 - 120 - 22420

Index

- Page 1 Index
- Page 2 Components
- Page 3 Parts Drawings & Lists
- Page 6 Wiring Diagrams
- Page 9 Maintenance
- Pag 12 Troubleshooting



Parts

Vacuum Unit

- 1 EDTK060 Tank Assembly, 60 gal
- 2 A-1928-3HP Control Panel
- 3 EDOLUN0303 3HP Motor, Model 03 Pump & Oil Reclaimer

Hose Stand 260-284

- 4 646-7hex Hex Head Aluminum Bolts
- 5 A-1705 Momentary Mushroom Switch Red
- 6 A-1704 Momentary Switch Green
- 7 A-1693-2 Pump-Out Instruction Sign
- 8 A-1693-3 Pump-Out Logo Sign

Bronze Hydrant 270BR-150

- 9 152MF-150BR Quick Clamp Adapter 1 1/2" FQC X MNPT
- 10 269BR-150 Bronze Swing Check Valve
- 11 264-150BR Ball Valve 1.5" Brass
- 12 A-0000 90 Degree Street Elbow Bronze
- 13 A-0000 1 1/2" Close Nipple, Bronze
- 14 A-0000 Threaded Bronze Mounting Plate

Hose Assembly 261-25-150

- 15 262-25-150 Hose
- 16 269CL-150 Clear Swing Check Valve
- 17 264-90-150 90 Degree Ball Valve 1.5"
- 18 152FM-150NY Quick Clamp Adapter 1 1/2" FQC X MNPT
- 19 158MF-150NY Quick Clamp Adapter 1 1/2" MQC X FNPT

Pump Out Adapters

- 20 273-150 1 1/2" Deck Adapter
- 21 273-125 1 1/4" Deck Adapter
- 22 272QC-150 QC Pump Out Nozzle
- 23 274-150 Potty Wand

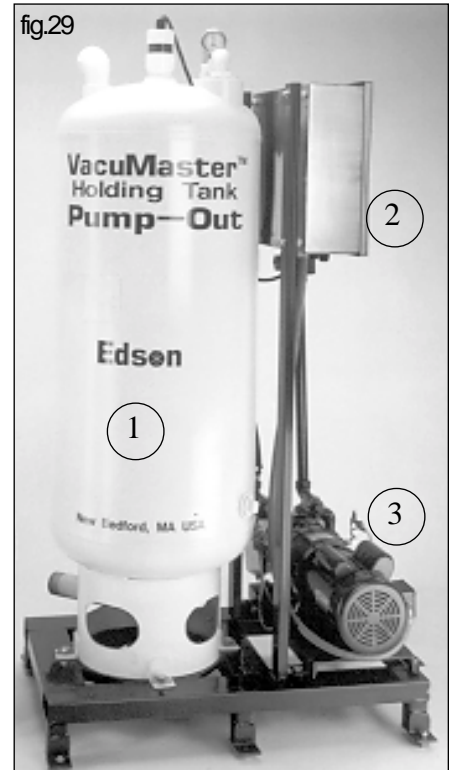
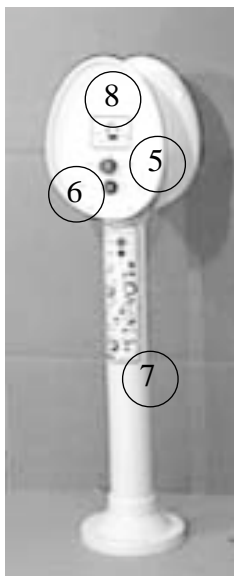
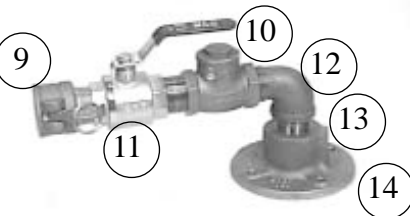
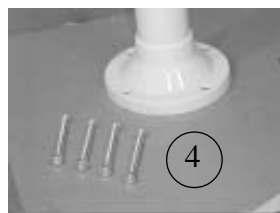

fig.30



Hose Stand 260-284



Bronze Hydrant 270BR-150

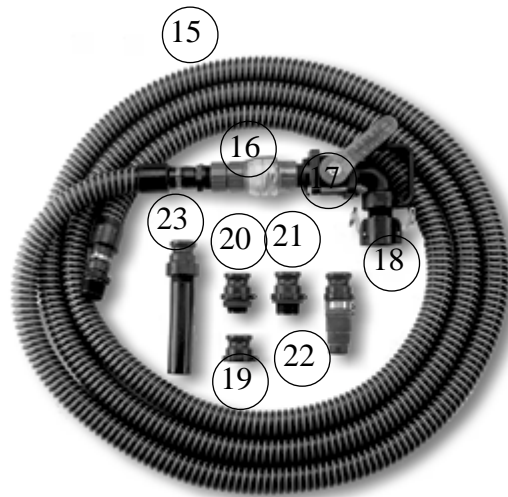

SUBASSEMBLY - EDSON TANK ASSEMBLY, 60 GALLONS - # EDTK060

ITEM	PART NO.	DESCRIPTION	QTY
1.	EDPA060	EDSON PROBE ASSEMBLY - 60 GALLON	1
2.	EDPT601120	EDSON PRIMARY TRAP	1
3.	PFTG107510	TEE GALVANIZED 1 X 3/4" X 1"	1
4.	PFNGC100	NIPPLE, CLOSE GALVANIZED 1"	2
5.	PFNG100013	NIPPLE, GALVANIZED 1 X 13" SCHEDULE 40	1
6.	PFTCG100	CROSS GALVANIZED 1"	1
7.	PFBG100025	BUSHING, GALVANIZED 1 X 1/4"	1
8.	PFBG100075	BUSHING, GALVANIZED 1 X 3/4"	1
9.	RVP10	PRESSURE/VACUUM RELIEF VALVE	2
10.	GAGE012	GAUGE, VAC/PRESS. LIQUID FILLED	1
11.	LWTR02	1" NPT POLY TRAP W/BALL	1
12.	PFBHB100100	HOSE BARB 1" X 1" NPT, BRASS	3
13.	PFPG150	PIPE PLUG, GALV 1-1/2"	2
14.	HOSELWP100	HOSE 1" PETROLEUM	7
15.	CLAMP020	CLAMP SS T20 (620-020)	4
16.	PFEGS200	STREET ELBOW, GALVANIZED 2"	3
17.	PFNG200600	NIPPLE, GALVANIZED 2" X 6" SCHEDULE 40	1
18.	PFCV200P	CHECK VALVE 2", CLEAR PLATIC	2
19.	1PVAD200A	PVC CLEANOUT ADAPTOR 2"	3
20.	1PVN200250	NIPPLE, PVC 2 X 2-1/2"	1
21.	PFNG200800	NIPPLE, GALVANIZED 2 X 8"	1
22.	PFTG202010	TEE GALVANIZED 2 X 2 X 1	1
23.	PFNGC200	NIPPLE, CLOSE GALVANIZED 2"	1
24.	PFEGS100	STREET ELBOW, GALVANIZED 1" 90 DEG	1

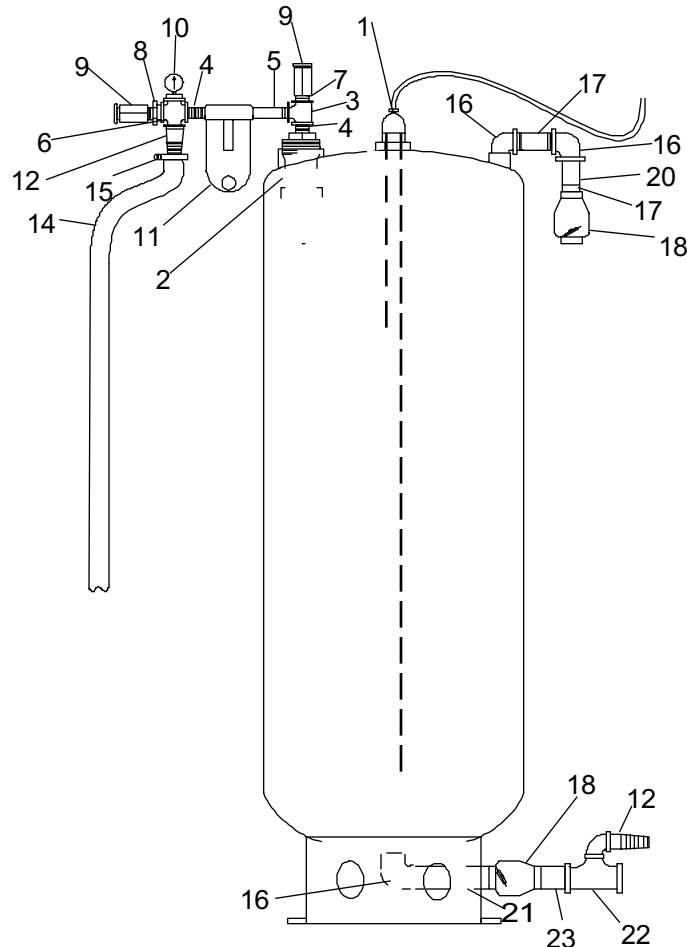

SUBASSEMBLY - VAPOR OIL PUMP, 1 HP SINGE PHASE UNIT - # EDOLUN0301

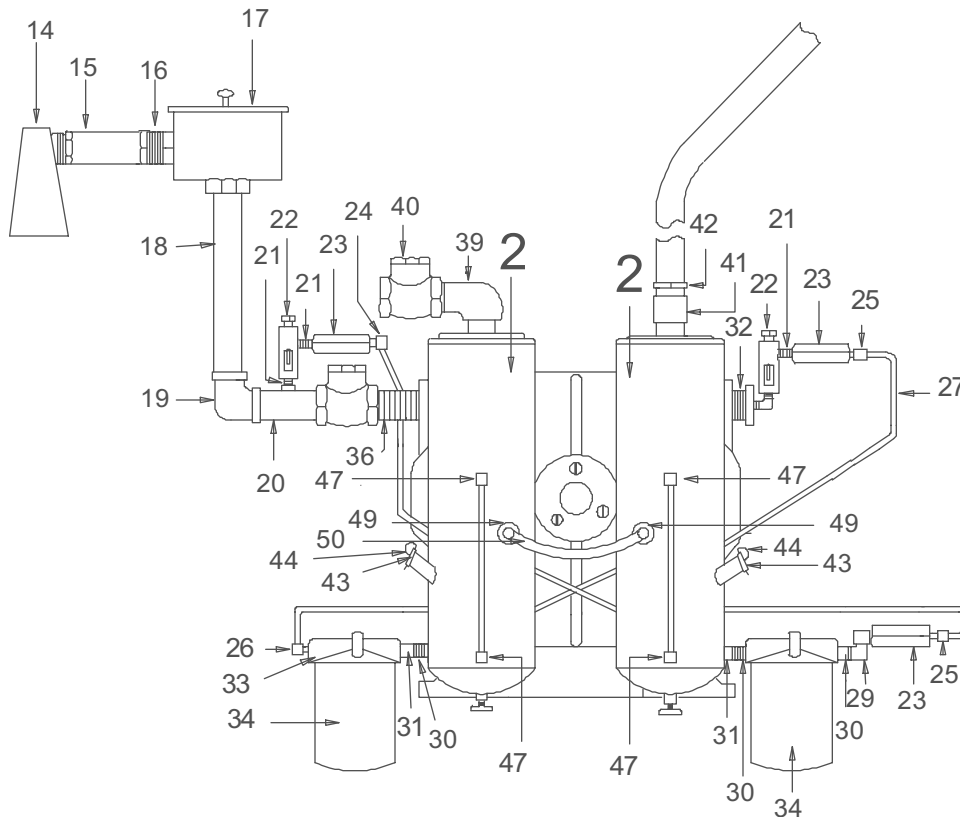
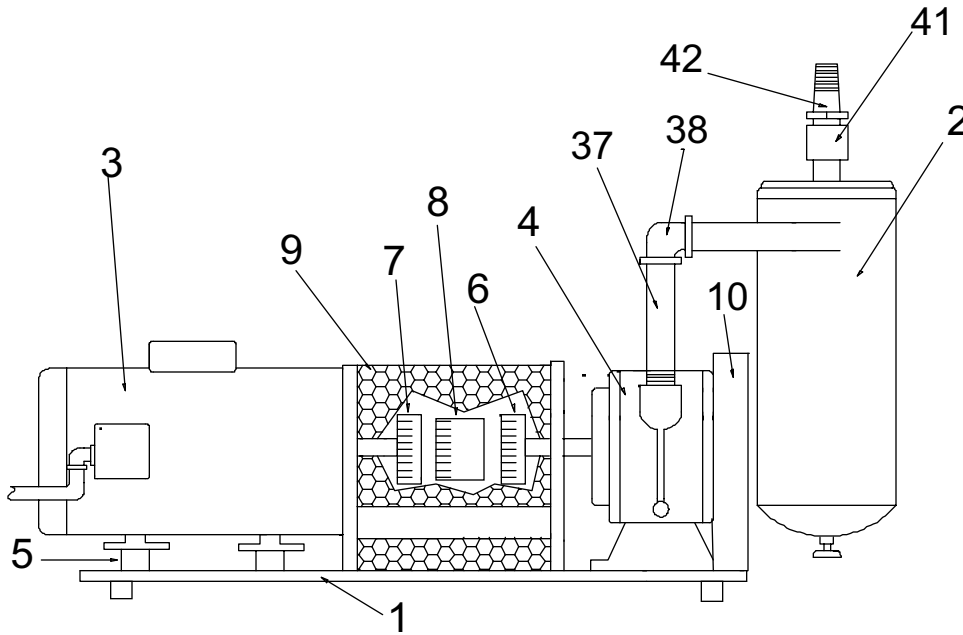

SUBASSEMBLY - VAPOR OIL PUMP, 3 HP SINGE PHASE UNIT - # EDOLUN0303

ITEM	PART NO.	DESCRIPTION	QTY
1.	EDBA013	EDSON BASE, 1 HP/3HP VO UNIT	1
2.	EDOR013	EDSON OIL RECLAIMER BODY	2
3.	MT3B	MOTOR, 3HP 1 PHASE, 1750 RPM	1
4.	OL03RV	MODEL 3 RADIAL VANE VAPOR OIL PUMP	1
6.	PUCFL6J1	COUPLING FLANGE 6J X 1"	1
7.	PUCFL6J118	COUPLING FLANGE 6J X 1-1/8"	1
8.	PUCSL6JES	COUPLING SLEEVE 6JES	1
9.	GRDC3612	COUPLING GUARD	1
10.	GRDF3612	FAN GUARD	1
11.	FS31150B	BOLT, 5/16-18 X 1.50 LAG STAINLESS	4
12.	FSW31087	WASHER, 5/16 X 7/8 USS FLAT	8
13.	FSN31	NUT, 5/16 - 18 UNC FIN HEX, ZINC PLATED GRADE 2	4
14.	EDMP01	INLET PROTECTOR	1
15.	PFCVBC100	CHECK VALVE, BALL CONE 1"	1
16.	PFNC100	NIPPLE, CLOSE 1"	1
17.	FLTAL06	ALUMINUM FILTER W/ CARTRIDGE 1"FNPT	1
18.	PFNB10008	NIPPLE, BI 1" X 8"	1
19.	PFEB100075	ELBOW BI 90 DEG 1 X 3/4"	1
20.	PFNB075250A	NIPPLE BI 3/4" X 2-1/2" W/ 1/8" HALF COUPLING	1
21.	PF215PN-2	BRASS CLOSE NIPPLE 1/8" NPT , 90 DEG	4
22.	SV007	OIL DRIPPER	2
23.	PFCVB018	BALL CHECK VALVE 1/8", BRASS	3
24.	PF269CA-4-2	BRASS COMPRESSION ALIGN MALE, ELBOW 1/8" X 1/4"	1
25.	PF68CA-4-2	BRASS COMPRESS. MALE CONNECT 1/8" NPT X 1/4"	1
26.	PF269CA-4-4	BRASS COMPRESS. ALIGN MALE EL. 1/4" NPT X 1/4"	1
27.	RWCPTUB010	COPPER TUBE 1/4"	2
28.	PF2202P-2-2	BRASS STREET ELBOW 90 DEG 1/8" NPT	2
29.	PF2202P-4-2	BRASS STREET ELBOW 90 DEG, 1/8" NPT X 1/4" NPT	1
30.	PF215PN-4	BRASS CLOSE NIPPLE 1/4" NPT 90 DEG	2
31.	PF2202P-4-4	BRASS STREET ELBOW 90 DEG 1/4" NPT	2
32.	PF209P-12-2	BRASS BUSHING 3/4" X 1/8"	1
33.	FLTLW02	OIL FILTER HEAD	2
34.	FLTLW10	OIL FILTER	2
35.	PFNC075	NIPPLE, CLOSE 3/4"	1
36.	PFNB07505	NIPPLE, BI 3/4" X 5"	2
37.	PFEB075	ELBOW, BI 90 DEG, 3/4"	1
38.	PFEB075	ELBOW, BI 90 DEG, 3/4"	1
39.	PFEB075	ELBOW, BI 90 DEG, 3/4"	1
39.	PFEB075	ELBOW, BI 90 DEG, 3/4"	1
39.	PFEB075	ELBOW, BI 90 DEG, 3/4"	1
39.	PFEB075	ELBOW, BI 90 DEG, 3/4"	1
39.	PFEB075	ELBOW, BI 90 DEG, 3/4"	1
39.	PFEB075	ELBOW, BI 90 DEG, 3/4"	1
40.	PFCV100	SWING CHECK VALVE 1"	1
41.	PFCB100	COUPLING, BI 1"	1
42.	PFBHB100100	HOSE BARB 1" X 1" NPT, BRASS	2
43.	EDMPO2	ALUMINUM FILL PLUGS FOR OILER	2
44.	EDMP03	OILER PLUG SAFETY CLIPS	2
44.	EDMP04	CABLE 1/16 T-304 RED VINYL	1
46.	EDMP05	SWEDGES	2
47.	PF169P-4-2	POLY-TITE MALE ELBOW 90 DEG 1/8" NPT X 1/4"	4
48.	RWPLTUB004	PLASTIC TUBE 1/4"	1
49.	PF68CA-2-2	BRASS COMPRESS. ALIGN MALE STR, CONN. 1/8" X 1/8	2
50.	RWCPTUB005	COPPER TUBE 1/8"	



L1

N

5 92 a nd 5 92b Series Cōntr ol Circuit

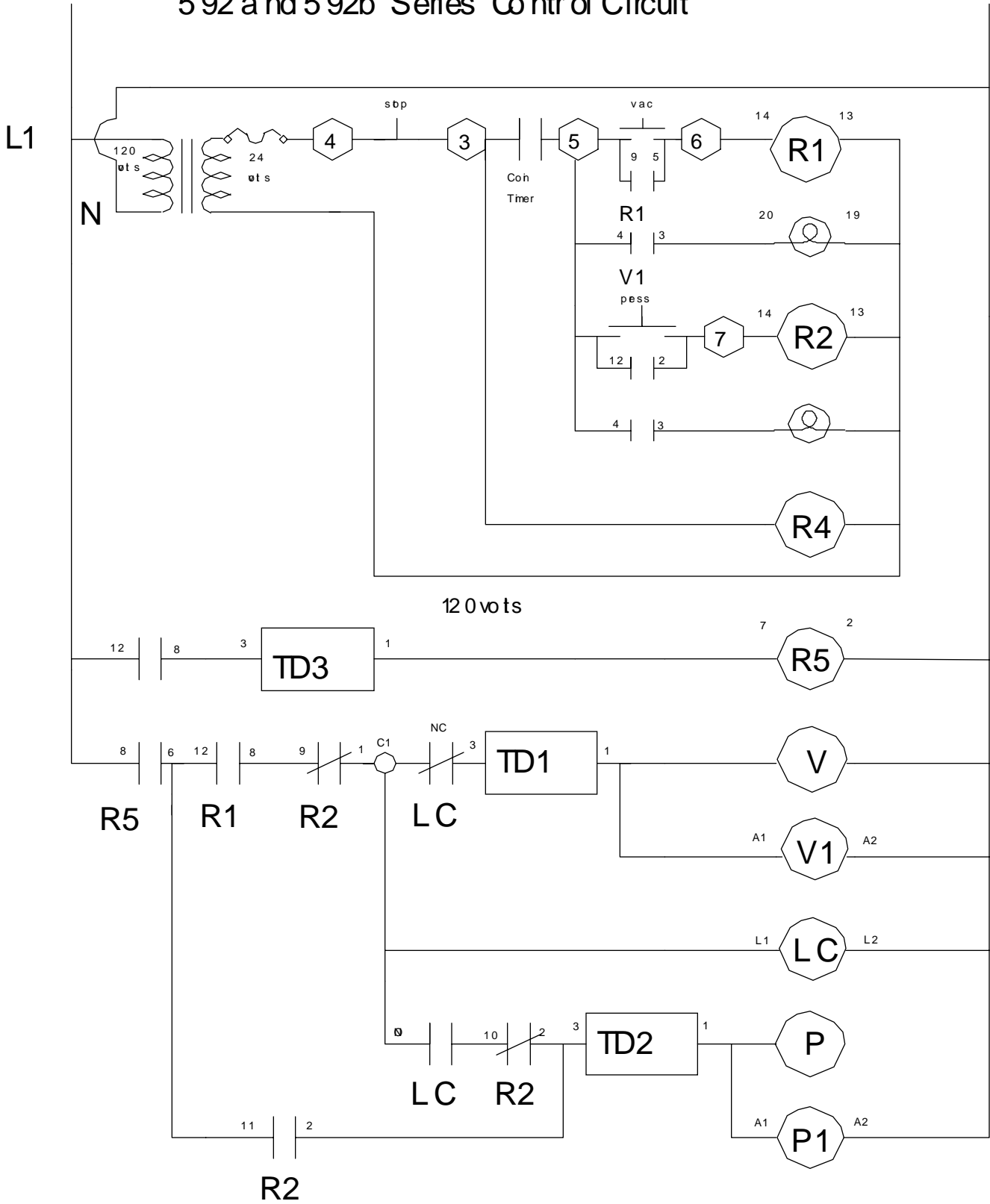

290 3 HP Wiring Diagram

Start/Stop Stations - Timers & Counters

Important Note:
Jumpers represented by Dashed Lines
Only Used When Timer is Not Used.

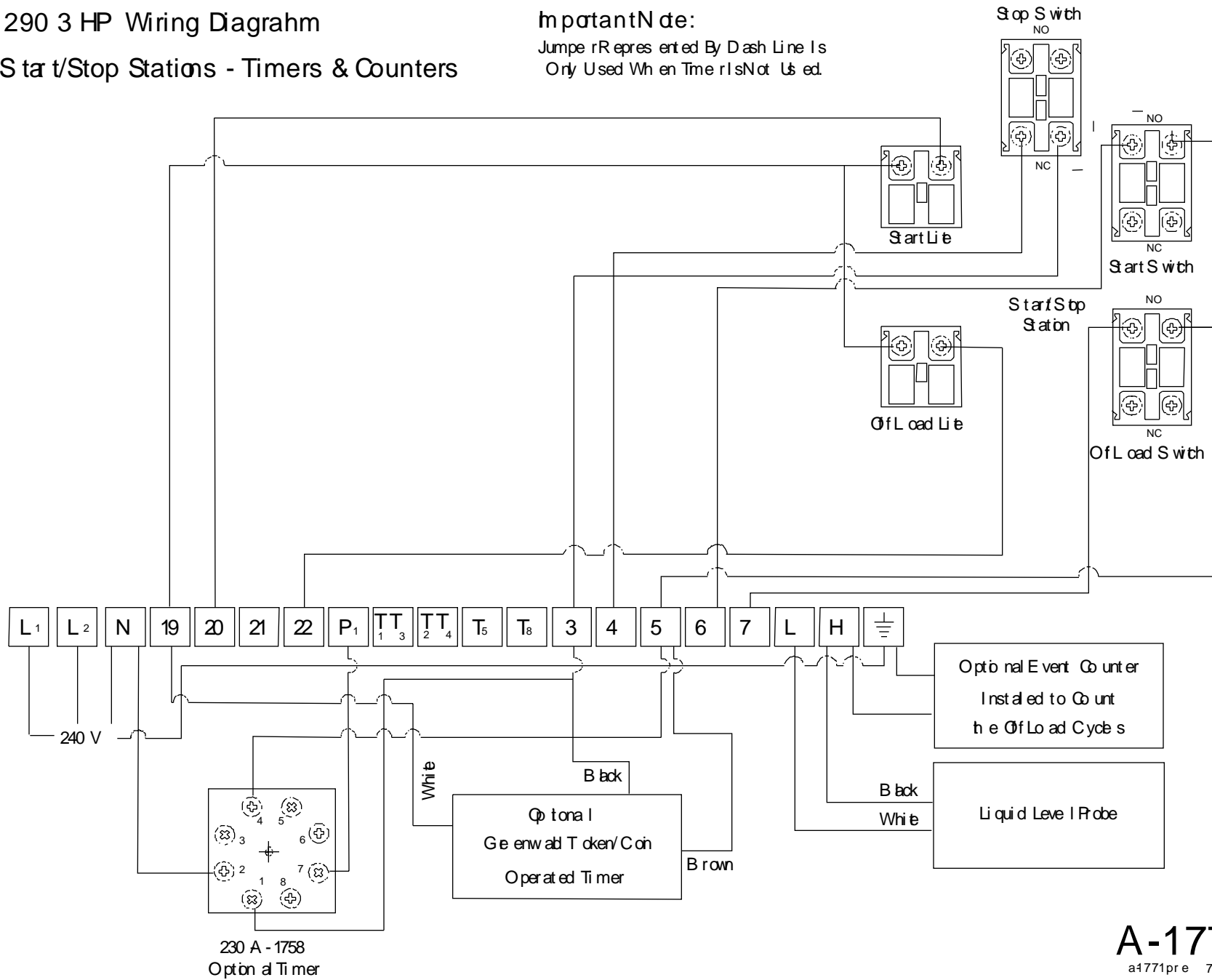

Control Panel Locator - 592 120 Volt Panel

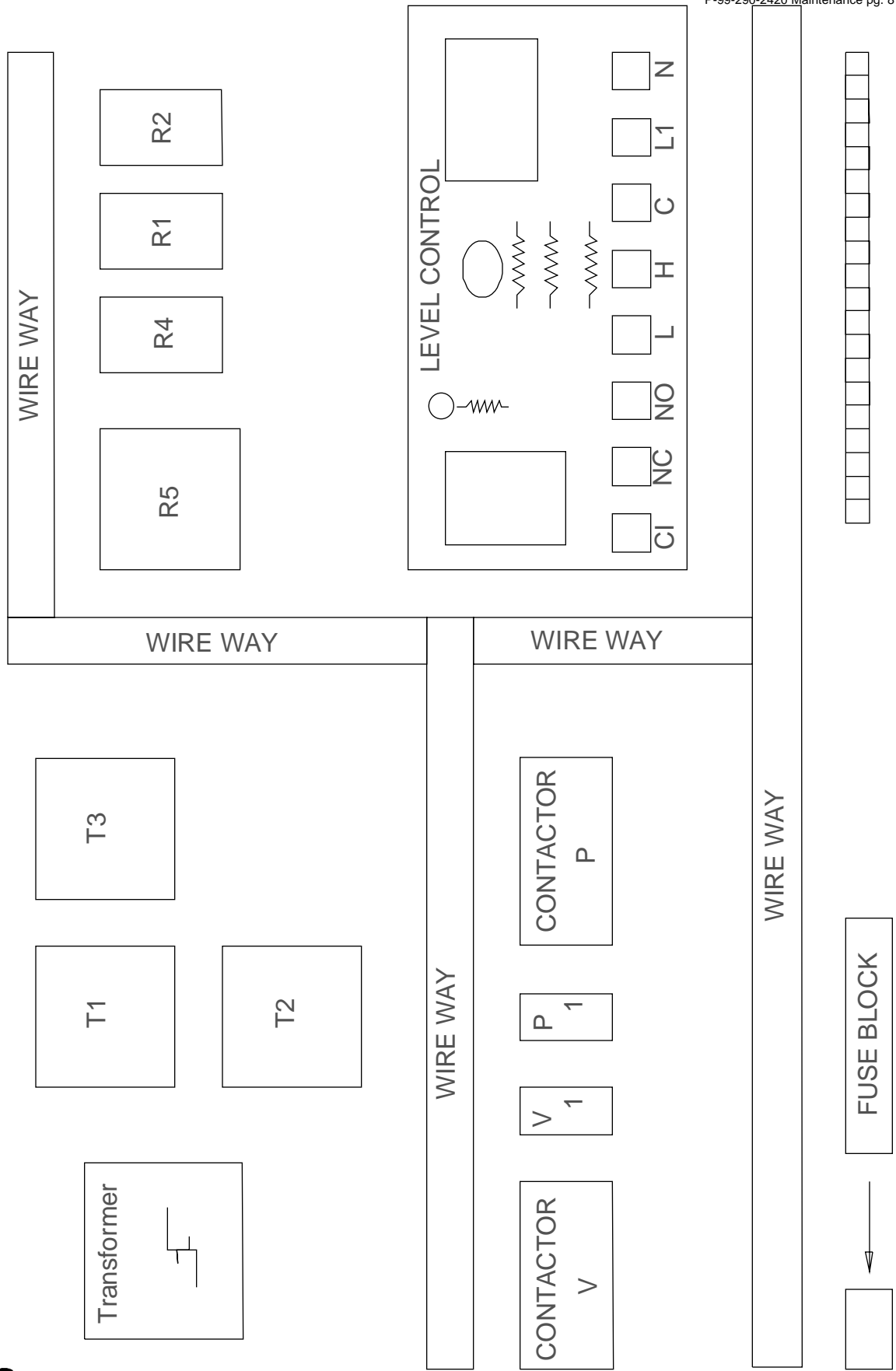

Oil Recycler

WARNING

Pressure Gauge Must Read 0 (Zero)
Oil Recycler Is Under Pressure When The Vacuum System Is On. Do Not Try To Fill, Open Or Remove Any Component of the Oiler While The System Is On. Injury Could Occur As A Result.

IMPORTANT

Use High Detergent 10W-30 or 10W-40 Motor Oil Only
Using the wrong oil or dirty oil can cause loss of vacuum or pump failure.

- **Check Oil Level Regularly** - add oil as required to maintain level.
- **Check for Excessive Moisture** & draining off excess water via the drains at the bottom of the reclaimer (F).
It is the nature of this oiler reclaimer that a small amount of water will mix with the oil. The oil in the sight tube will appear cloudy due to picking up air and water as it passes through the pump and is reclaimed. Since water is heavier than oil excess water will settle to the bottom of the recyclers. Drain until a small amount of oil appears in a clear glass. If more than an ounce water drains out the oil and filters should be changed.
- **Change the Oil and Filters (D)** twice a year if system is used year round or once a year if use is seasonal. Drain oil before removing filters.
- **Check Oil Drippers.** Drippers have been preset at the factory to allow approximately one drip of oil to enter the system every five (5) seconds. If they need to be reset follow these instructions.
- **Setting Oil Drippers (C)**
 - Vacuum Dripper
 - a. Start the unit in the vacuum mode and shut off the inlet ball valve.
 - b. Let the unit build up to maximum vacuum.
 - c. Vacuum dripper is on the back side of the pump, closest to the waste tank.
 - d. Unscrew the locknut on top of the dripper. With a slot-head screwdriver, unscrew the dripper jet by turning it in a counter clockwise direction. Turn the jet until the oil line fills with oil to the dripper. Then slowly tighten the jet in a clockwise direction until dripper is dripping about one drop every 5 seconds. Replace the lock nut and tighten in a clockwise direction.
 - Pressure Dripper
 - a. Start the unit in the pressure mode and shut off the discharge ball valve.
 - b. Pressure dripper is on the back side of the pump, closest to the waste tank.
 - c. Unscrew the locknut on top of the dripper. With a slot-head screwdriver, unscrew the dripper jet by turning it in a counter clockwise direction. Turn the jet until the oil line fills with oil to the dripper. Then slowly tighten the jet in a clockwise direction until dripper is dripping about one drop every 5 seconds. Replace the lock nut and tighten in a clockwise direction.

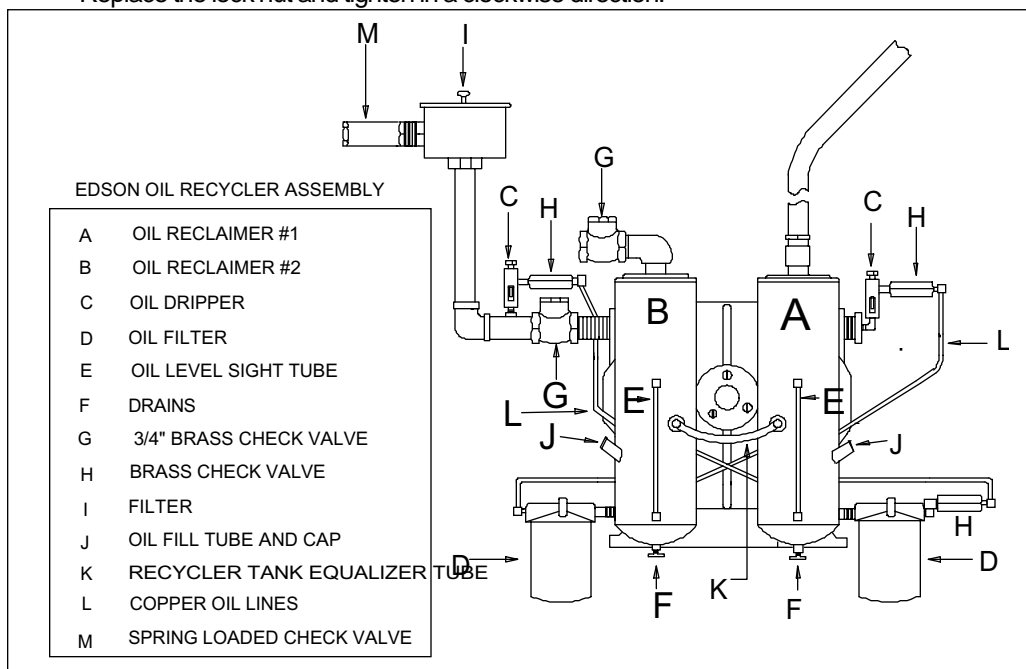



- 1 Vacuum Regulator
- 1 Pressure Regulator
- 1 90° Street Elbow Pressure Regulator on early VacuMasters are installed vertically. The elbow was added to change position to horizontal.

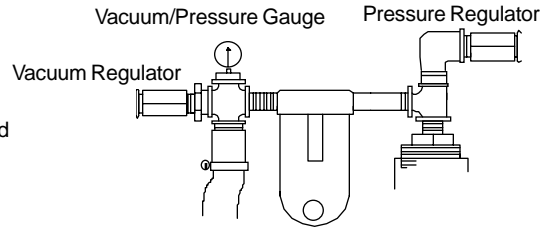

WARNING

Never Adjust The Pressure Regulator When The System Is On or There Is A Pressure Reading On The Gauge. The Adjusting Nut Could Blow Off And Cause Serious Injury

Warning

Insure System Is Depressurized Befor Removing Any Parts. Failure to Do So Can Result In Injury.

- **Check Vacuum Setting Regularly** - Adjust as required. The right setting is the one set at installation. It allowed the tank vacuum pressure to build to the level that will suck sewage from the boats to the tank. Vacuum Reading Should Be: _____ hg

To Adjust Vacuum Regulator

- Step 1 Close Inlet and Discharge Ball Valves Sealing Tank
- Step 2 Turn VacuMaster On.
- Step 3 Run in Vacuum Mode
- Step 4 Loosen Locking Nut Counter Clockwise On Regulator
- Step 5 Turn Knurled Hub Clock Wise to Increase Vacuum At Which Valve Opens Counter Clockwise for Lower Pressure.
- Step 6 Tighten Locking Nut.

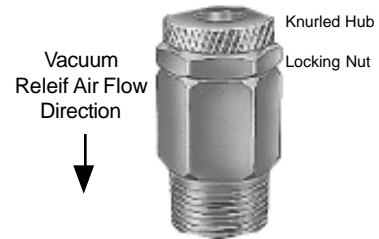

- **Check Pressure Setting Regularly** - Adjust as required. The right setting is the one set at installation. It allowed the tank pressure to build to the level that will discharge sewage from the tank. Pressure reading Should Be: _____ psi

To Adjust Pressure Regulator

- Step 1 Seal Tank by Closing Inlet and Discharge Ball Valves
- Step 2 Run in Off Load Mode and Watch Gage. If pressure reading reaches tank maximum pressure rating and regulator has not open turn VacuMaster off immediately and proceed to step 4.
- Step 3 Turn VacuMaster Off and Allow Tank To Depressurize. Do Not Adjust Pressure Regulator With System On. Regulator Adjusting Screw Could Blow Loose and Cause Bodily Injury
- Step 4 Loosen Locking Nut Counter Clockwise On Regulator
- Step 5 Turn Knurled Hub Clock Wise to Increase Vacuum At Which Valve Opens. Counter Clockwise for Lower Pressure.
- Step 6 Tighten Locking Nut. Repeat Steps 2-6 Until Desired Setting Is Reached.

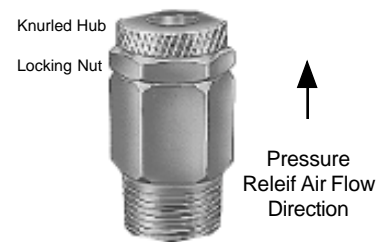

- **Clean Regulators Annually:** Take each regulator apart and wipe clean. Reassemble and adjust per above instructions.

Air Filter

- **Check Periodically** - Replace as required. Order# 161-A-1629-A
The air filter is found inside the canister (I). It is a cartridge filter that removes particulates from ambient air when the vacuumaster is in the pressure mode.

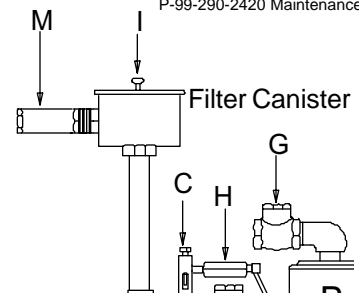

Moisture Traps

- **Visual Check Daily**- The Edson unit is equipped with a primary ball and cage shutoff which is built into the tank. This primary shutoff will shut off the vacuum line to the pump in the event the level control probe fails. A secondary clear bowl moisture trap is installed on the tank to pump line in case any moisture or waste gets past the primary shutoff. This clear bowl trap should be checked periodically for moisture and drained accordingly.

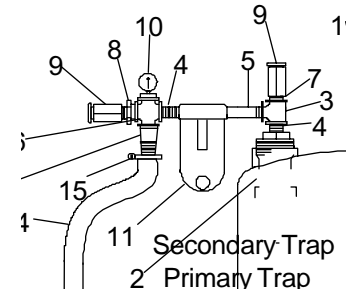

Check Valves

- **Visual Check Daily**- Each Edson unit is equipped with two clear 2" check valves. (Some Applications require BRONZE CHECK VALVES)
The check valves are designed to operate automatically, opening and closing when the unit switches from vacuum to pressure mode.
In the vacuum mode, the check valve mounted near the top to the tank should be open. If the unit is not pumping properly or pumping is taking longer than normal, the intake check valve should be checked to see if any debris is keeping it from opening completely. Because the check valve is clear, a visual inspection to determine any problems is easy. If the intake check valve is functioning properly, the outlet check valve should be viewed to see if it is closing properly during the vacuum mode. If debris is preventing the outlet check valve from properly sealing, exhaust waste can be sucked back into the unit, filling the tank prematurely and affecting vacuum levels. The outlet check valve is also clear for easy inspection. If the unit does not discharge properly, the outlet and inlet check valves should also be inspected for clogging.

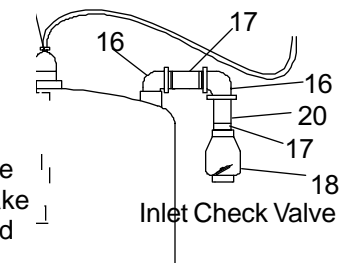

If a check valve is clogged, it may be removed for cleaning. The check valves are screwed in using regular NPT threads. Since the check valves are plastic, care should be taken while unscrewing them with a standard pipe wrench. It is a good idea to install two shutoff ball valves in front and behind the discharge check valve during installation. This insures a minimal amount of mess while removing the discharge check valve in the event that either the tank or the discharge line is full of waste.

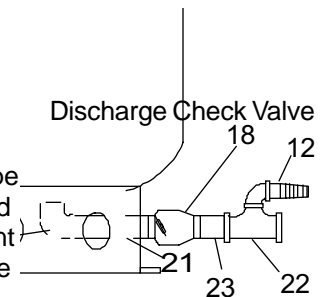

Air Pump

- **As Required** - The air pump is a combination vacuum/pressure pump. It is built for years service. The only maintenance required is to keep the oil reservoirs full so that the pump does not run dry and to drain any moisture from the recyclers and the secondary trap.

If the air pump gets a significant amount of water, it will be necessary to flush the vane chamber with kerosene and then change the oil in the recyclers and replace the oil filters.

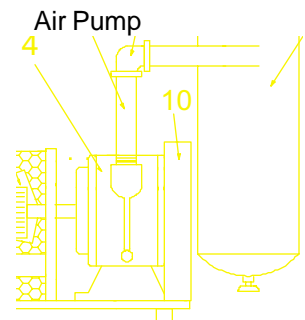

Flushing The Air Pump

- Unscrew Filter Cap nut, remove filter cap and the filter.
- Pour about 1/2 cup of kerosene into the filter canister. It will drain down into the **pump**.
- Press the Off Load Button and let the pump run in the pressure mode for about 15 seconds. If pump will not run let the kerosene sit for two hours. Try and turn the pump by hand. If it still will not turn, wait one day. If after one day the pump will not turn over, the pump must be disassembled and cleaned.
- After running kerosene through the pump the Oil Recyclers must be drained and refilled.

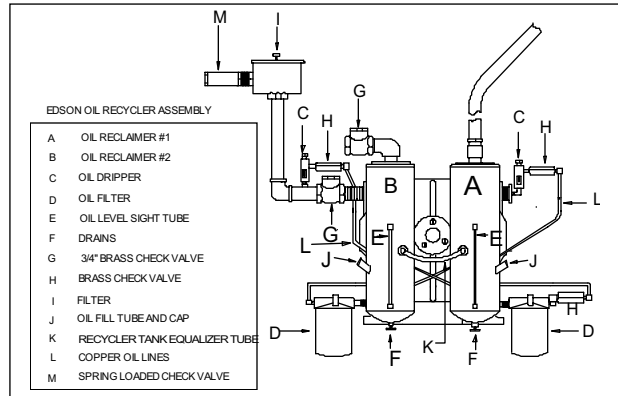

Trouble Shooting

Condition: No Vacuum At The Pump Out Hose

After pressing the green start button and waiting approximately 2 minutes before opening the pump out hose ball valve, there is no indication of a vacuum. Close ball valve on the hose and see Steps below.

Isolating The Problem

Step 1 - Check motor. Push green start button at the pump unit.

1. Motor is not running. See Electrical & Level Control.
2. Motor is running in vacuum mode but there is low or 0 vacuum reading on the pressure gauge at top of the tank. Proceed to Step 2

Step 2 - Check for tank pressure leak. Close inlet and discharge ball valves on the tank.

1. Vacuum gauge stays the same. Check air pump by removing tank hose from pump. If no vacuum at air pump port, flush air pump with kerosene (See Maintenance - Flushing Air Pump.). If strong vacuum at air pump, there is an air leak or a blockage in the tank air line plumbing. Check the regulators, primary and secondary traps and exhaust line.
2. Vacuum gauge builds vacuum to regulator preset. Proceed to Step 3

Step 3 - Isolate pressure leak. With unit running in vacuum open discharge ball valve.

1. Vacuum gauge drops. Clean Discharge Check Valve .
2. Vacuum gauge holds vacuum to regulator preset. Proceed to Step 4

Step 4 - With unit running and pump out hose ball valve closed open tank inlet ball valve.

1. Vacuum gauge drops. Check for break in suction line. See Plumbing
2. Vacuum gauge holds vacuum to regulator preset. Go back to work.

Condition: The Secondary Trap Is Completely Filled With Waste Water

This condition would indicate that the level control switch may not have shut off the motor or may be set to high.

1. Run unit in pressure mode to clear sytem of water & drain seconary trap:
2. Run unit in vacuum with just water and to determine if unit cycles properly.
3. If unit failes to reverse when tank is full, stop and remove probes and clean probes. Check electrical continuity. Test unit again. If it works, flush the air pump and change the oil. If it doesn't work problem is electrical. Call Edson for quidelines.

Condition: Oil Recycler Oil is White In Color

This is a natural effect of the oil reclaiming process and it cause by moisture emulsified in the oil. See Maintenance - Oil Recycler